

Operator's Manual



McELROY

www.mcelroy.com



412 and 618 Fusion Machines

Original Language: English

Manual: 1869401 Revision: G 04/14

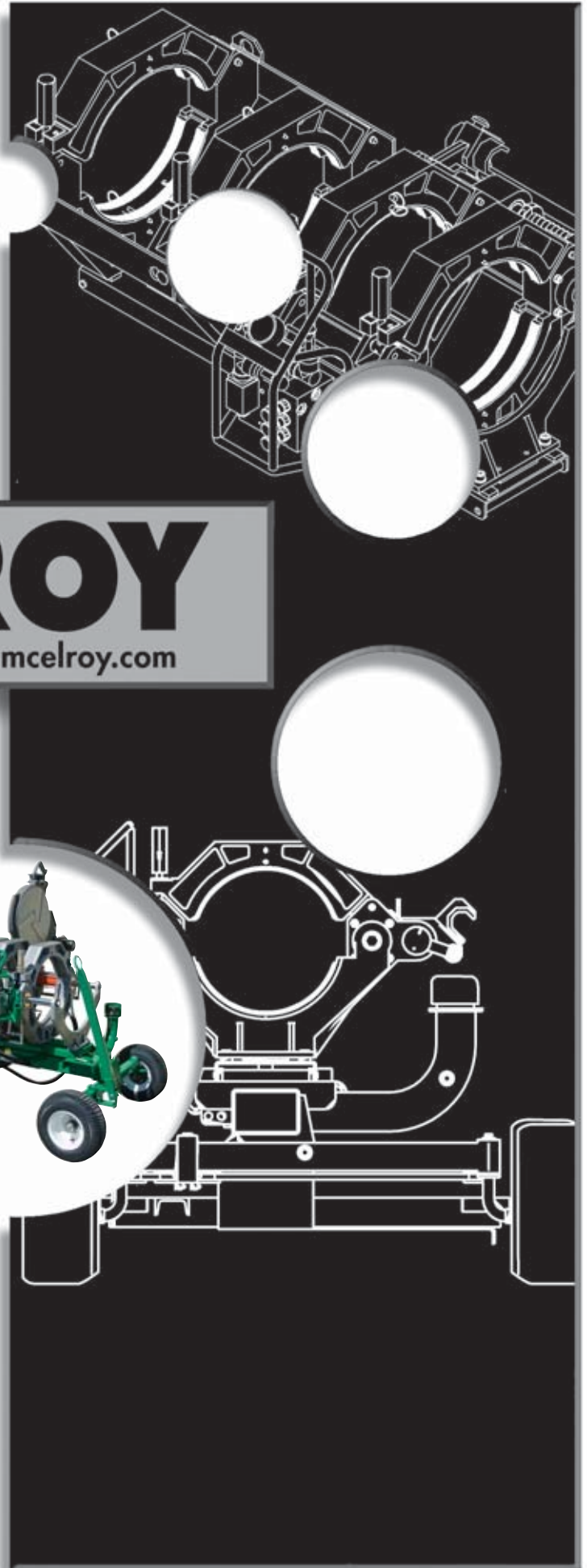

This product and other products could be protected by patents or have patents pending. All the latest patent information is available at patent.mcelroy.com

California Proposition 65 Warning

Engine exhaust from this product contains chemicals known to the State of California to cause cancer, birth defects, or other reproductive harm.



Introduction



Thank you for purchasing this McElroy product.

The 412 and 618 model fusion machines are self-contained and designed to butt fuse polyethylene pipe. If fusing other thermoplastic pipe materials, refer to the pipe manufacturer's fusion procedures or appropriate joining standard.

The 412 model fuses 4" IPS (4.50" OD) minimum, to 12" DIPS (13.2" OD) maximum pipe.

The 618 model fuses 6" IPS (6-5/8" OD) minimum to 18" IPS (18" OD) maximum pipe.

With reasonable care and maintenance, these machines will give years of satisfactory service.

TX01186-5-5-11

Before operating this machine, please read this manual thoroughly, and keep a copy with the machine for future reference. This manual is to be considered part of your machine.

Always return the manual to the literature compartment.



McElroy University

For more than 30 years, McElroy has been the only pipe fusion machine manufacturer to continuously offer advanced training. Course offerings are meant to enhance your efficiency, productivity and safety in the proper use of McElroy machines. McElroy University classes are structured so that the skills learned and the machines used in each class closely match the machines found on pipelining jobsites. We offer training at our facility or yours. Our uniquely qualified McElroy University course instructors offer years of industry experience.

Tuition for each course includes lunches, course materials and a certificate of completion. Online registration, as well as up-to-date course offerings and dates, is available at www.mcelroy.com/university

This manual is intended as a guide only and does not take the place of proper training by qualified instructors. The information in this manual is not all inclusive and can not encompass all possible situations that can be encountered during various operations.

TX04659-03-24-14



MU2-03-13-14



Warranty



LIMITED WARRANTY

McElroy Manufacturing, Inc. (McElroy) warrants all products manufactured, sold and repaired by it to be free from defects in materials and workmanship, its obligation under this warranty being limited to repairing or replacing at its factory and new products, within **5 years** after shipment, with the exception of purchased items (such as electronic devices, pumps, switches, etc.), in which case that manufacturer's warranty applies. Warranty applies when returned freight is prepaid and which, upon examination, shall disclose to have been defective. This warranty does not apply to any product or component which has been repaired or altered by anyone other than McElroy or has become damaged due to misuse, negligence or casualty, or has not been operated or maintained according to McElroy's printed instructions and warnings. This warranty is expressly in lieu of all other warranties expressed or implied. The remedies of the Buyer are the exclusive and sole remedies available and Buyer shall not be entitled to receive any incidental or consequential damages. Buyer waives the benefit of any rule that disclaimer of warranty shall be construed against McElroy and agrees that such disclaimers herein shall be construed liberally in favor of McElroy.

RETURN OF GOODS

Buyer agrees not to return goods for any reason except upon the written consent of McElroy obtained in advance of such return, which consent, if given, shall specify the terms and conditions and charges upon which any such return may be made. Materials returned to McElroy, for warranty work, repair, etc., **must have a Return Material Authorization (RMA) number**, and be so noted on the package at time of shipment. For assistance, inquiry shall be directed to:

McElroy Manufacturing, Inc.
 P.O. Box 580550
 833 North Fulton Street Tulsa, Oklahoma 74158-0550
 PHONE: (918) 836-8611, FAX: (918) 831-9285.
 EMAIL: fusion@McElroy.com

Note: Certain repairs, warranty work, and inquiries may be directed, at McElroy's discretion, to an authorized service center or distributor.

DISCLAIMER OF LIABILITY

McElroy accepts no responsibility of liability for fusion joints. Operation and maintenance of the product is the responsibility of others. We recommend qualified joining procedures be followed when using McElroy fusion equipment.

McElroy makes no other warranty of any kind whatever, express or implied; and all implied warranties of merchantability and fitness for a particular purpose which exceed the aforesaid obligation are hereby disclaimed by McElroy.

PRODUCT IMPROVEMENT

McElroy reserves the right to make any changes in or improvements on its products without incurring any liability or obligation to update or change previously sold machines and/or the accessories thereto.

INFORMATION DISCLOSED

No information of knowledge heretofore or hereafter disclosed to McElroy in the performance of or in connection with the terms hereof, shall be deemed to be confidential or proprietary, unless otherwise expressly agreed to in writing by McElroy and any such information or knowledge shall be free from restrictions, other than a claim for patent infringement, is part of the consideration hereof.

PROPRIETARY RIGHTS

All proprietary rights pertaining to the equipment or the components of the equipment to be delivered by McElroy hereunder, and all patent rights therein, arising prior to, or in the course of, or as a result of the design or fabrication of the said product, are exclusively the property of McElroy.

LAW APPLICABLE

All sales shall be governed by the Uniform Commercial Code of Oklahoma, U.S.A.

**Register your product online to activate your warranty:
www.McElroy.com/fusion**

(Copy information listed on the machine nameplate here for your records).

Model No. _____

Serial No. _____

Date Received _____

Distributor _____



Table of Contents



Equipment Safety

Safety Alerts	1-1
Read and Understand	1-1
General Safety	1-2
Wear Safety Equipment	1-2
Fuel Handling	1-2
Units with Engines	1-3
Carbon Monoxide	1-3
Heater is Not Explosion Proof	1-3
Electric Motors are Not Explosion Proof	1-3
Battery	1-4
Electrical Safety	1-4
Units with Hydraulics	1-5
Crush Points	1-5
Facer Blades are Sharp	1-5
Have Tires Properly Serviced.	1-6
Do Not Tow Fusion Machine at Speeds Greater than 5 MPH	1-6
Heater is Hot.	1-6
Fusion Procedures	1-6
Positioning Fusion Machine.	1-7

Overview

Theory of Heat Fusion	2-1
Carriage Assembly	2-2
Chassis.	2-2
Gas Powered Units	2-3
Tac and Hour Meter.	2-3
Electrical Units.	2-4
Volt Meter.	2-4
Power for Heater	2-4
Hydraulic Fluid Reservoir	2-5
Hydraulic Manifold Block	2-5
Filter.	2-5
Hydraulic Cylinders	2-6
Pipe Lift	2-6
Facer	2-7
Insulated Heater Stand	2-7
Heater Stripper Bar	2-7
Heater	2-8

COPYRIGHT © 2014, 2011
 McELROY MANUFACTURING, INC.
 Tulsa, Oklahoma

All product names or trademarks are property of their respective owners. All information, illustrations and specifications in this manual are based on the latest information available at the time of publication. The right is reserved to make changes at any time without notice.



Table of Contents



Operation

Read Before Operating	3-1
Check Oil Level	3-1
Connecting Electric Unit to Power	3-1
Gas Powered Units	3-1
Prepare Heater	3-2
Set up Pipe Supports	3-2
Install Clamping Inserts.	3-3
Loading Pipe into Machine	3-3
Positioning Pipe into Machine	3-3
Begin Facing.	3-4
After Facing	3-4
Determine Drag Pressure	3-5
Set Fusion Pressure.	3-5
Check for Slippage	3-5
Check Alignment	3-6
Position Carriage for Heater Insertion	3-6
Check Heater Temperature	3-6
Inserting Heater.	3-7
Heat Pipe	3-7
Fusing the Pipe	3-8
Opening Movable Jaws	3-8
Opening Fixed Jaws	3-8
Raise Pipe.	3-9
Position Pipe for Next Joint.	3-9
Install Next Piece of Pipe	3-9

Special Operations - In Ditch

Remove Facer from 412 and 618 Machine	4-1
Remove Carriage Assembly from the Chassis	4-2
Remove 3-Jaw Assembly from the Carriage	4-3
Manual Facer Operation	4-4
Outrigger	4-4
Removing Top Jaws	4-5
Lower 3-Jaw or 4-Jaw Carriage into Ditch.	4-5
Clamp Carriage Assembly to Pipe	4-6
Lower Facer into Ditch	4-7
Attach Hydraulic Hoses	4-7
Make Fusion Joint	4-7
Remove Carriage Assembly from Ditch.	4-7
Reassemble Fusion Machine	4-8

Lifting Fusion Machine

Lifting Safety	5-1
Lifting Sling	5-2
Lift Equipment	5-2



Table of Contents



Maintenance

Preventative Maintenance	6-1
Washing the Machine	6-1
Check Hydraulic Fluid	6-1
Change Hydraulic Fluid and Filter	6-1
Check Gauge	6-2
Clean Jaws and Inserts	6-2
Clean Thrust Bearings	6-2
Clean Eyebolt Threads	6-2
Bleeding Air from Hydraulic System	6-3
Facer Blades	6-3
Clean Heater Surfaces	6-3
Installing Butt Fusion Heater Plates	6-4
Adjusting Heater Temperature	6-4
Heater Indicator Light	6-4
Fasteners Must be Tight	6-5

Machine Maintenance Checklist

Maintenance Checklist	7-1
---------------------------------	-----

Determining Fusion Pressure

Determining Fusion Pressure	8-1
---------------------------------------	-----

Hydraulic Fluids

Hydraulic Fluid Characteristics	9-1
---	-----

Specifications

Fusion Machine Specifications	10-1
Generator Sizing Form	10-3



Fusion Equipment Safety



Safety Alerts

This hazard alert sign  appears in this manual. When you see this sign, carefully read what it says. **YOUR SAFETY IS AT STAKE.**

You will see the hazard alert sign with these words: **DANGER**, **WARNING**, and **CAUTION**.



WR00051-11-30-92



DANGER Indicates an imminently hazardous situation which, if not avoided, will result in death or serious injury.



WARNING Indicates a potentially hazardous situation which, if not avoided, could result in death or serious injury.



CAUTION Indicates a hazardous situation which, if not avoided, may result in minor or moderate injury.



In this manual you should look for two other words: **NOTICE** and **IMPORTANT**.

NOTICE: can keep you from doing something that might damage the machine or someone's property. It may also be used to alert against unsafe practices.

IMPORTANT: can help you do a better job or make your job easier in some way.

TX00030-12-1-92

Read and Understand

Do not operate this equipment until you have carefully read, and understand all the sections of this manual, and all other equipment manuals that will be used with it.

Your safety and the safety of others depends upon care and judgment in the operation of this equipment.

Follow all applicable federal, state, local, and industry specific regulations.

McElroy Manufacturing, Inc. cannot anticipate every possible circumstance that might involve a potential hazard. The warnings in this manual and on the machine are therefore not all inclusive. You must satisfy yourself that a procedure, tool, work method, or operating technique is safe for you and others. You should also ensure that the machine will not be damaged or made unsafe by the method of operation or maintenance you choose.



WR00052-12-1-92

TX02946-4-15-09



Fusion Equipment Safety



General Safety

Safety is important. Report anything unusual that you notice during set up or operation.

LISTEN for thumps, bumps, rattles, squeals, air leaks, or unusual sounds.

SMELL odors like burning insulation, hot metal, burning rubber, hot oil, or natural gas.

FEEL any changes in the way the equipment operates.

SEE problems with wiring and cables, hydraulic connections, or other equipment.

REPORT anything you see, feel, smell, or hear that is different from what you expect, or that you think may be unsafe.



SAFE1ST-12-22-92

TX00114-4-22-93

Wear Safety Equipment

Wear a hard hat, safety shoes, safety glasses, and other applicable personal protective equipment.

Remove jewelry and rings, and do not wear loose-fitting clothing or long hair that could catch on controls or moving machinery.

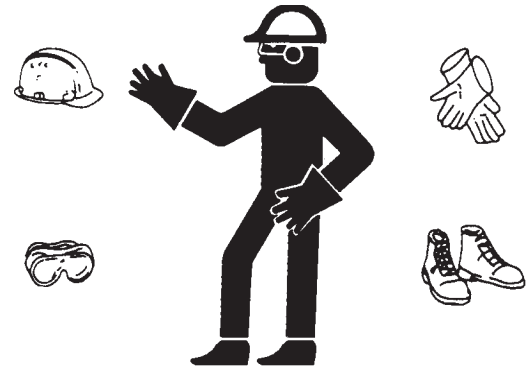

WR00053-12-2-92

TX00032-4-7-93

Fuel Handling

⚠ DANGER Gasoline and diesel fuel are extremely flammable and their vapors will explode if ignited.

Do not fill the fuel tank while the engine is hot or running, as spilled fuel could ignite.

Refuel in a well ventilated area. Do not smoke or allow flames or sparks in the area where the engine is refueled, or where gasoline is stored.

Do not start the engine near spilled fuel. Wipe up spills immediately.

Make sure the fuel tank cap is closed and properly secured.

NOTICE: Avoid repeated or prolonged contact with skin or breathing of vapor.

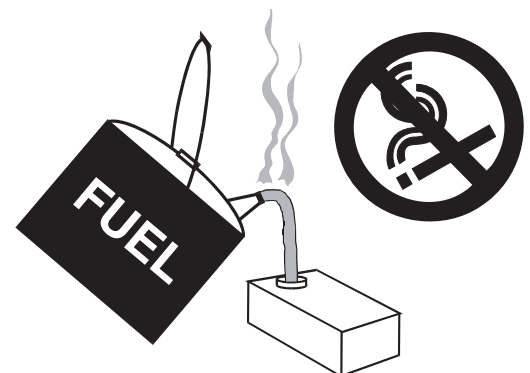

CD00065-2-19-97

TX00953-3-30-11



Fusion Equipment Safety



Units With Engines

⚠ DANGER

Combustion engines can cause explosions when operated in an explosive atmosphere. Do not operate gas or diesel powered machines in an explosive atmosphere.

When operating in an explosive atmosphere, keep engine and chassis in a safe area by using hydraulic extension hoses.

Help prevent fires by keeping machine clean of accumulated trash, debris and facer shavings.

TX01266-04-28-14



WR00080-4-12-93

Carbon Monoxide

⚠ DANGER

Engine exhaust gases contain poisonous carbon monoxide. Carbon monoxide can cause severe nausea, fainting and death. Avoid inhaling exhaust fumes and never run the engine in a closed or confined area.

TX00954-5-14-96



WR00093-5-14-96

Heater Is Not Explosion Proof

⚠ DANGER

This heater is not explosion proof. Operation of heater in an explosive atmosphere without necessary safety precautions will result in serious injury or death.

If operating in an explosive atmosphere, the heater should be brought up to temperature in a safe environment, then **unplugged before entering** the explosive atmosphere for fusion.

TX00100-04-28-14



WR00034-11-30-92

Electric Motors are Not Explosion Proof

⚠ DANGER

Electric motors are not explosion proof. Operation of these components in an explosive atmosphere without necessary safety precautions will result in serious injury or death.

When operating in an explosive atmosphere, keep pump motor and chassis in a safe area by using hydraulic extension hoses.

TX00424-04-28-14



WR00080-4-12-93



Fusion Equipment Safety



Battery



Do not expose the battery to flames or electrical sparks. Hydrogen gas generated by battery action is explosive. Blindness or serious injury can result from an exploding battery.



Do not allow battery fluid to contact your skin, eyes, fabrics, or painted surfaces. Sulfuric acid can cause burns. After touching a battery or battery cap, do not touch or rub your eyes.

Eye Contact: Flush eyes with large amounts of water for at least 15 minutes. Seek immediate medical attention if eyes have been exposed directly to acid.

Skin Contact: Flush affected area(s) with large amounts of water using deluge emergency shower, if available, shower for at least 15 minutes. Remove contaminated clothing. If symptoms persist, seek medical attention.



TX00650-3-7-11

CD00176-9-14-95

CD00177-9-14-95

Electrical Safety



Always ensure equipment is properly grounded. It is important to remember that you are working in a wet environment with electrical devices. Proper ground connections help to minimize the chances of an electric shock.



Frequently inspect electrical cords and unit for damage. Have damaged components replaced and service performed by a qualified electrician.

NOTICE: Always connect units to the proper power source as listed on the unit, or in the owner's manual.

NOTICE: Disconnect the machine from the power source before attempting any maintenance or adjustment.



Disconnect the machine from the power source before attempting to service the control panel. Failure to disconnect the power could result in serious injury or death due to electric shock. Refer service to a qualified technician.



TX03003-3-30-11

WR00055-4-7-93

WR00025-11-30-92



Units With Hydraulics

It is important to remember that a sudden hydraulic oil leak can cause serious injury, or even be fatal if the pressure is high enough.

⚠ WARNING Escaping fluid under pressure can penetrate the skin causing serious injury. Keep hands and body away from pinholes which eject fluid under pressure. Use a piece of cardboard or paper to search for leaks. If any fluid is injected into the skin, it must be immediately removed by a doctor familiar with this type of injury.

⚠ WARNING Unwanted movement of the machine could result in serious injury or damage to machine. Unwanted movement of the machine may take place if switches do not match machine state when the machine power is turned on.

NOTICE: Wear safety glasses, and keep face clear of area when bleeding air from hydraulic system to avoid spraying oil into eyes.

TX03007-10-12-10

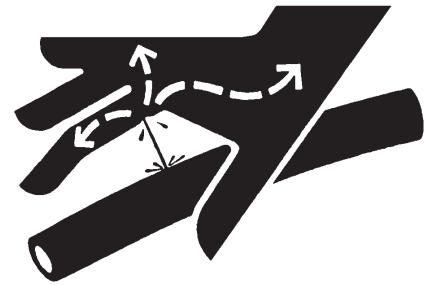

WR00078-4-8-93

Crush Points

⚠ WARNING Hydraulically operated equipment is operated under pressure. Anything caught in the machine will be crushed. Keep fingers, feet, arms, legs, and head out of the machine while operated.

TX03004-8-11-09



WR00012-12-4-92

Facer Blades Are Sharp

⚠ WARNING Facer blades are sharp and can cut. Never attempt to remove shavings while the facer is running, or is in the facing position between the jaws. Use care when operating the facer, and when handling the unit.

NOTICE: Disconnect power from the facer, and remove the facer blades before attempting any maintenance or adjustment.

NOTICE: Never extend the blade beyond the inner or outer circumference of the facer.

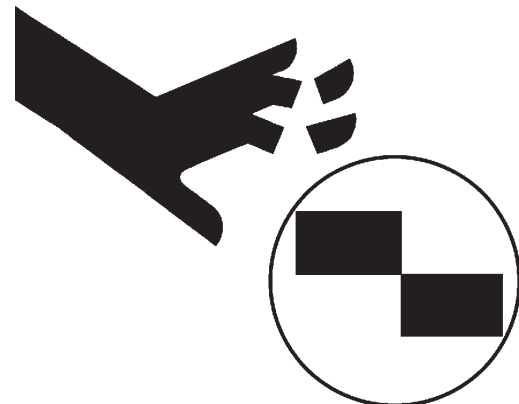

WR00073-4-6-93

TX02378-1-24-05



Fusion Equipment Safety



Have Tires Properly Serviced

⚠️ WARNING Failure to follow proper procedures when mounting a tire on a wheel or rim can produce an explosion which may result in serious injury or death. Have tires mounted by someone that is experienced, and has the proper equipment to perform the job safely.

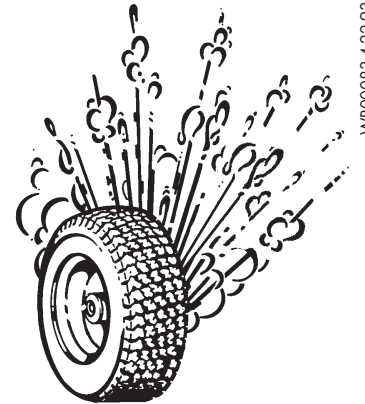

TX00118-4-22-93

WR00083-4-22-93

Do Not Tow Fusion Machine At Speeds Greater Than 5 MPH

⚠️ WARNING The chassis is not designed for over-road towing. Towing at speeds greater than five miles per hour can result in machine damage as well as injury. Always transport the machine by flat bed trailer or similar means, and make sure that unit is properly secured.

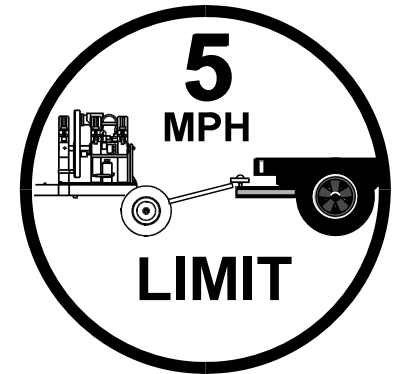

TX04271-5-5-11

CD00189-1-24-96

Heater Is Hot

⚠️ CAUTION The heater is hot and will burn clothing and skin. Keep the heater in its insulated heater shroud when not in use, and use care when heating the pipe.

NOTICE: Use only a clean non-synthetic cloth to clean the heater plates.



TX04244-10-12-10

WR00030-2-10-93

Fusion Procedures

Obtain a copy of the pipe manufacturer's procedures for the pipe being fused. Follow the procedure carefully, and adhere to all specified parameters.

NOTICE: Failure to follow pipe manufacturer's procedure could result in a bad joint. Always follow pipe manufacturer's procedures.

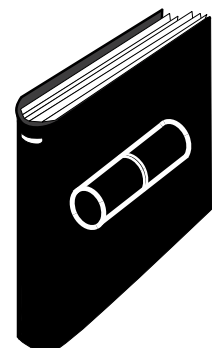

TX02984-5-22-12

WR00079-1-24-96



Fusion Equipment Safety



Positioning Fusion Machine

Place fusion machine on as level ground as possible, and set the brake on the rear wheel. If it is necessary to operate machine on unlevel grade, chock the wheels and block the unit to make it as stable as possible.

TX00112-9-15-94

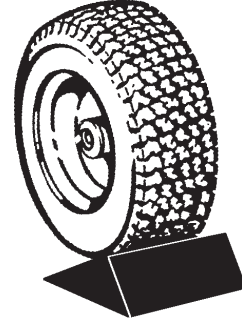

WR00076-4-7-93

Theory of Heat Fusion

The principle of heat fusion is to heat two surfaces to a designated temperature, and then fuse them together by application of force. This pressure causes flow of the melted materials, which causes mixing and thus fusion. When the polyethylene material is heated, the molecular structure is transformed from a crystalline state into an amorphous condition. When fusion pressure is applied, the molecules from each polyethylene part mix. As the joint cools, the molecules return to their crystalline form, the original interfaces are gone, and the fitting and pipe have become one homogeneous unit. A strong, fully leak tight connection is the result.

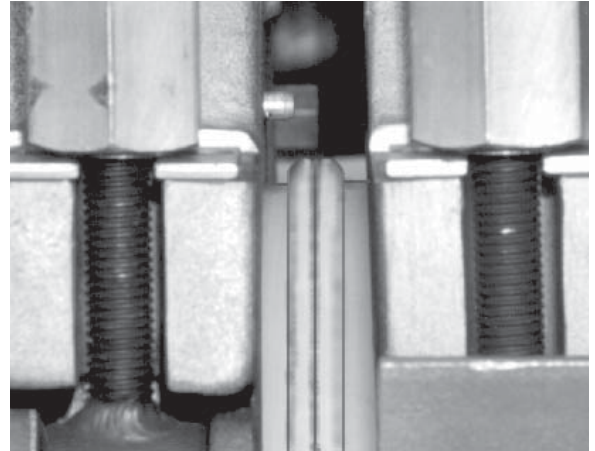

PH00363B9-12.94

The principal operations include:

- Clamping** The pipe pieces held axially to allow all subsequent operations to take place.
- Facing** The pipe ends must be faced to establish clean, parallel mating surfaces perpendicular to the centerline of the pipes.
- Aligning** The pipe ends must be aligned with each other to minimize mismatch or high-low of the pipe walls.
- Heating** A melt pattern that penetrates into the pipe must be formed around both pipe ends.
- Joining** The melt patterns must be joined with a specified force. The force must be constant around the interface area.
- Holding** The molten joint must be held immobile with a specified force until adequately cooled.
- Inspecting** Visually examine the entire circumference of the joint for compliance with standards established by your company, customer, industry, federal, state, or local regulations.



Overview



Carriage Assembly

The carriage assembly consists of two fixed jaws and two hydraulically operated movable jaws bolted to the skid. For remote operation the carriage can be set in ditch and connected to the machine with optional hydraulic extension hoses. The carriage assembly (A) can be disconnected from the chassis (B) and removed for remote operation. The optional extension hose kit is required for this operation.

For tight installations the outer fixed jaw and skid can be removed from the carriage for an even more compact fusion unit.

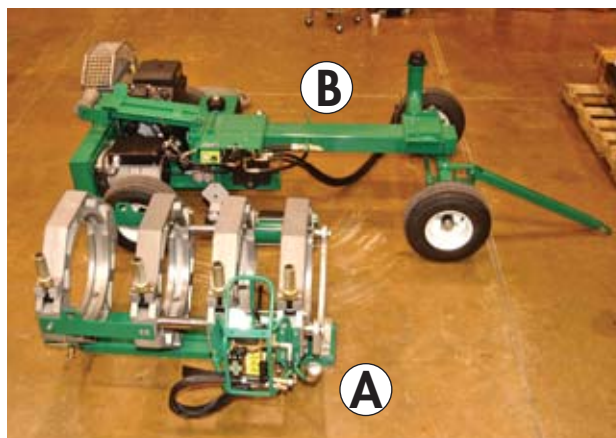

PH02588-09-18-03

TX01891-11-15-00

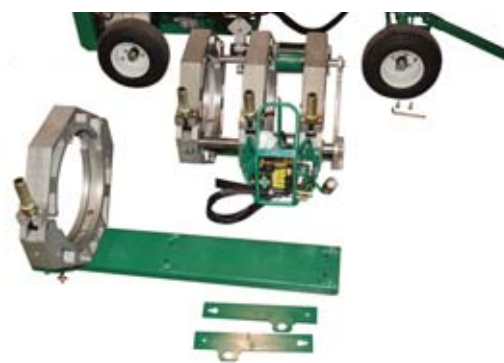

PH02592-09-18-03

Chassis

The carriage assembly is mounted on a four wheel chassis for mobility and movement along the pipe line.

There is a wheel lock on the right rear wheel to prevent rolling.

⚠ WARNING Towing at speeds greater than 5 mph can result in machine damage as well as injury. Always transport the machine by flatbed truck or similar means.

The tongue on the tow bar has a ring so that the machine may be conveniently maneuvered at the job site.

The chassis is not designed for over-road towing.



PH04552-5-5-11



PH02597-09-18-03

TX02214-5-5-11



Overview



Gas Powered Units

Read the operating and maintenance instructions for the engine before operating.



PH02599-09-18-03

The engine has a choke control and key ignition for easy electric starting.



PH02600-09-18-03

TX01257-2-19-97

Tac and Hour Meter

When the unit is running, the engine RPM's are displayed. When the unit is not running, total hours of engine operation are displayed.

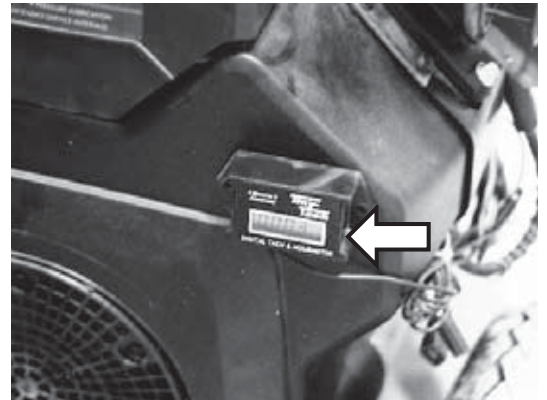

PH01055-2-19-97

TX01267-2-21-97



Overview



Electrical Units

Located on the top of the electrical box are power on and power off buttons and an hour meter that indicates how many hours the unit has been in operation.

A motor circuit breaker is included in the electrical box.

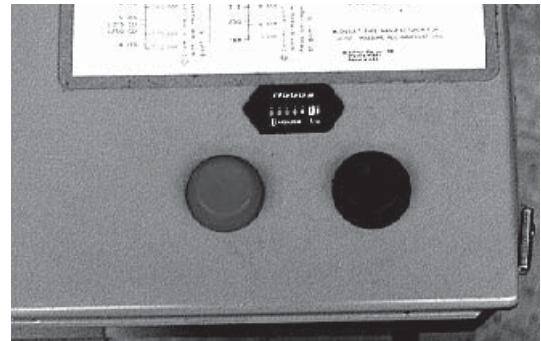

PH00919-8-16-96

TX01085-8-16-96

Volt Meter

The volt meter displays incoming volts of electricity to the machine.

The volt meter selector switch is next to the volt meter. This switch allows selection of each incoming phase of a 3-phase electrical system.

NOTICE: Low voltage will damage unit. Connect unit to adequate electrical power source. Ensure proper ground for electrical system.

If unit fails to start, check to see if the light on the reverse phase relay is on. If not, disconnect the power source and switch any two incoming power leads and try again. If the unit still doesn't start and the light is on, contact a McElroy Authorized Service Center for assistance. The reverse phase relay ensures correct rotation of the pump motor so damage to the hydraulic system does not occur.

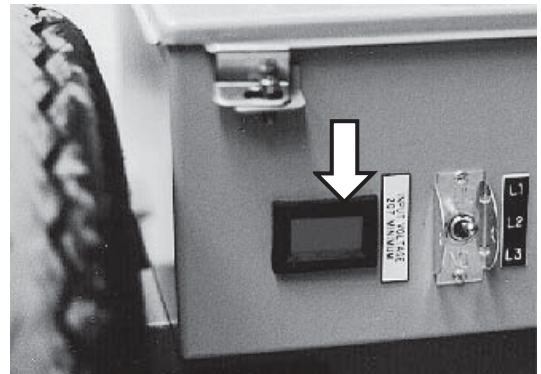

PH00637-12-95



PH00921-8-16-96

TX01086-5-5-11

Power for Heater

A receptacle is located on the chassis frame to supply power to the heater.

The machine has two 240V receptacles that are used to power a butt fusion heater.



PH04547-4-25-11

TX01087-5-5-11

Hydraulic Fluid Reservoir

The reservoir is incorporated in the chassis. The fluid level should remain visible in the **sight gauge** in the side of the filler spout.

Never allow dirt or other foreign matter to enter the open tank.

Refer to the "Hydraulic Fluids" section of this manual for hydraulic fluid recommendations.

TX00353-04-28-14



PH02602-09-18-03

Hydraulic Manifold Block

Mounted on this block are a carriage directional control valve, a pressure reducing selector valve, three pressure reducing valves, and a 1500 psi gauge.

- A) The carriage control valve, mounted on the top of the manifold, determines whether the carriage is moving left, right, or is in neutral.
- B) A 1500 psi gauge is mounted on top of the manifold.
- C) The selector valve, mounted on the front of the manifold, selects a reduced pressure from one of the pressure reducing valves.

Each pressure reducing valve is labeled with a different function:

- D) The top valve adjusts facing pressure to a maximum of 400 psi.
- E) The middle valve adjusts heating pressure to a maximum of 400 psi.
- F) The bottom valve adjusts fusion pressure to a maximum of 1500 psi.
- G) DataLogger port

TX00357-1-12-11



PH04548-5-5-11

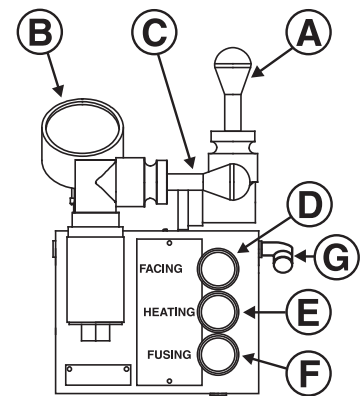

CD00138H-4-25-11

Filter

This machine is equipped with a 10 Micron filter located in the return line to the reservoir.

TX01269-2-21-97



PH02603-09-18-03

Hydraulic Cylinders

HIGH FORCE hydraulic carriage cylinders are painted green. High force cylinders are used when higher interfacial pressures are required, when handling heavy wall pipe, or when large drag factors need to be overcome.

MEDIUM FORCE cylinders are painted orange and have approximately half the total effective piston area as High Force cylinders. The cylinders move faster and are normally used for medium density pipe and when lower interfacial pressures are used.

LOW FORCE cylinders are painted yellow. These cylinders should be selected when fusing pipe with a very low interfacial pressure (22 psi).

IMPORTANT: Use the correct total effective piston area to calculate the gauge pressure.

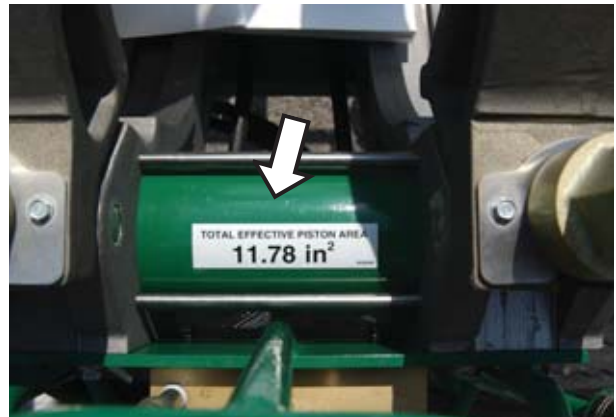

PH02573-09-18-03

TX01270-3-30-11

Pipe Lift

A pipe lift is provided to assist in pipe handling. The lift is activated by a hydraulic valve.



PH02575-09-18-03



PH02574-09-18-03

TX00813-12-18-96



Overview



Facer

The facer is a McElroy rotating planer-block design. The block rotates on a ball bearing and is chain driven by a hydraulic motor.

When fusing 4" and 6" diameter pipe on the 412 or 618 move the facer blades to the inboard position.

NOTICE: Never extend the blade beyond the inner or outer circumference of the facer.

TX02533-6-20-05



PH02576-09-18-03

Insulated Heater Stand

The heater should always be stored in the insulated heater stand or blanket for protection of the operator and to minimize heat loss and risk of mechanical damage.

TX00363-9-15-94



PH03874-4-15-09

Heater Stripper Bar

The heater is equipped with a stripper bar that is used to separate the heater from the pipe ends after the heating cycle. When the inner jaws are opened, the jaws lift and press against the stripper bar separating the heater from pipe ends.

TX02982-4-27-09

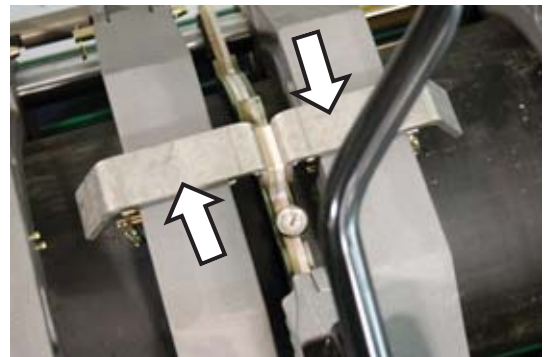

PH03906-4-17-09

Heater

⚠ DANGER

Heater is not explosion proof. Operation of heater in an explosive atmosphere without necessary safety precautions will result in serious injury or death.

If operating in an explosive atmosphere, heater should be brought up to temperature in a safe environment, then **unplugged before entering** the explosive atmosphere for fusion.

The heater has a green indicator light which will flash on and off. This indicates that the controller is operating normally. If the green indicator is not flashing then the controller may not be operating properly. If this occurs, disconnect power and have the heater repaired by an McElroy Authorized Service Center.

The heater temperature is controlled by a microprocessor. It has a red indicator light on the handle at the bottom of the temperature scale. When the heater is plugged in and preheating the light glows steadily until the set temperature is reached. The light then goes off and on slowly as the heater maintains temperature.

The heater body is not coated. Coated butt fusion heater plates are available for all butt fusion applications.

NOTICE: The heater should never be used without butt fusion heater plates installed.

To prevent a build-up of plastic pipe residue from accumulating on the heater plates (loss of surface temperature and pipe sticking may result), the heater plates should be cleaned with a non-synthetic cloth before every fusion joint.



PH03874-4-15-09



PH02313-6-28-02



PH02333-6-28-02



Operation



Read Before Operating

Before operating this machine, please read this manual thoroughly, and keep a copy with the machine for future reference.

Return manual to the protective storage box when not in use. This manual is to be considered part of your machine.

TX00401-9-15-94



STOP-112-28-95

Check Oil Level

Check oil level in sight gauge on filler spout and add oil if necessary.

Refer to the "Hydraulic Fluids" section of this manual for hydraulic oil recommendations.

If oil is not visible in the sight gauge, fill reservoir until oil is visible in the sight gauge.

Do not overfill reservoir. The oil will expand as it heats up.

Never allow dirt, water, or other foreign matter to enter the tank.

Use only clean oil from an unopened container.

TX04272-5-5-11



PH02602-09-18-03

Connecting Electric Unit to Power



All electrical equipment and power sources must be located in a nonexplosive atmosphere. Failure to do so can result in explosion and death.

Plug machine's electrical cord into a proper power source.

Open fuser valve and disconnect heater before turning unit on.

TX00817-04-28-14

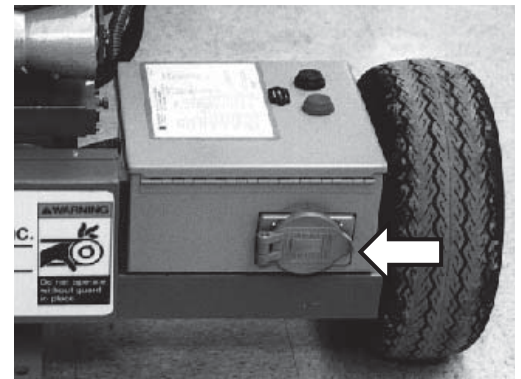

PH00647-12-20-95

Gas Powered Units

Read the operating and maintenance instructions for the engine before operating.

Open fuser valve and disconnect heater before starting engine.

Pull choke control out and turn ignition key to start engine.

Release key when engine starts.

Gradually push choke control in as engine starts and warms up.

TX01260-2-20-97



PH02600-09-18-03

Prepare Heater



Heater is not explosion proof. Operation of heater in an explosive atmosphere without necessary safety precautions will result in serious injury or death.

If operating in an explosive atmosphere, heater should be brought up to temperature in a safe environment, then unplugged before entering the explosive atmosphere for fusion.

Install butt fusion heater plates while heater is cool.

NOTICE: The heater should never be used without butt fusion heater plates installed. Refer to the "Maintenance" section of this manual for installation procedure.

Place heater in insulated heater stand.

Plug heater into the appropriate outlet on machine.

IMPORTANT: Engine must be in high speed to provide electric power to the heater.

Refer to the "Maintenance" section of this manual for instructions how to adjust heater temperature.

Allow heater to warm-up to operating temperature.



PH03874-4-15-09



PH04547-4-25-11

TX02310-03-24-14

Set up Pipe Supports

Set up pipe stands or pipe rollers and adjust height so the pipe is in line with the jaws.



PH03879-4-15-09

TX02955-4-15-09



Operation



Install Clamping Inserts

Select and install appropriate clamping inserts for the pipe that is being fused.

Clamping inserts are required for all sizes except sizes that match the size of the jaw without inserts.

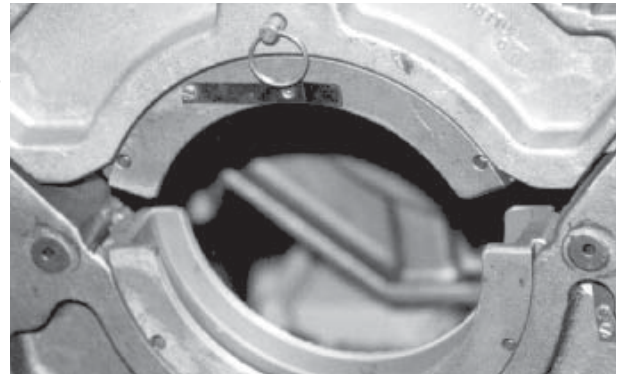

PH003049-24-93

TX02956-4-15-09

Loading Pipe Into Machine

Clean the inside and outside of pipe ends that are to be fused.

Open the upper jaws and insert pipe in each pair of jaws with applicable inserts installed. Position pipe with enough material protruding past the jaw faces to allow for facing of the pipe end.



PH01906-11-15-00

TX02339-3-30-11

Positioning Pipe In Machine

Swing the facer into place. With the carriage control valve lever, move the carriage toward the fixed jaws, while watching the gap at each end of the facer rest buttons. When the pipe is in contact with the facer, this gap indicates the amount of material that will be trimmed from the pipe end. Assure sufficient material will be removed for a complete face off. Tighten the clamp knobs on the outside jaws. Hand tighten the inside clamp knobs.

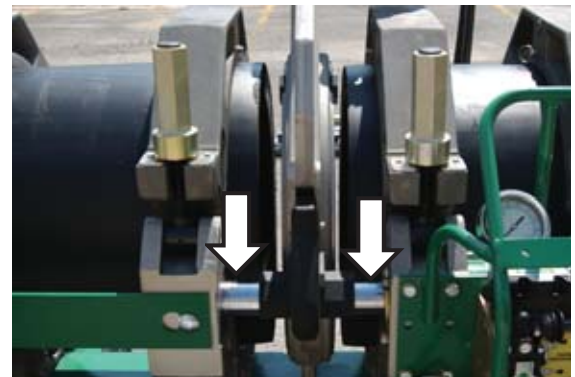

PH02577-09-18-03

TX00372-9-15-94

Begin Facing

Turn facer on by opening valve on top of the facer.

Move the selector valve on the hydraulic manifold block to the top (facing pressure) position.

The facing pressure should be set as low as possible while still facing pipe. Excessive facing pressure can damage the facer. It may be necessary to adjust the carriage pressure.

⚠ WARNING Facer blades are sharp and can cut. Never attempt to remove shavings while the facer is running, or is in the facing position between the jaws. Use care when operating the facer, and when handling the unit.

Activate the carriage control valve and move the carriage to the left to begin facing. Continue to face the pipe until the rest buttons on the jaws bottom out on the facer rest buttons.



PH02578-09-18-03

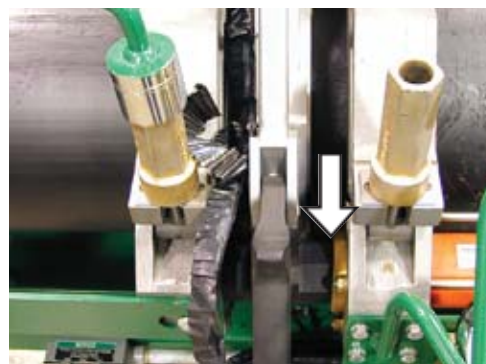

PH01901-11-15-00

TX04261-3-30-11

After Facing

Turn facer motor off. Move carriage all the way to the right. Center the facer in between the pipe ends to avoid dragging facer stops on the pipe ends. Swing facer to the out position. Clean shavings out of pipe ends and from between the jaws. Do not touch faced pipe ends.



PH02576-09-18-03

TX04262-3-30-11

Determine Drag Pressure

Drag pressure should be determined using the following procedure:

Move the carriage so that the faced pipe ends are approximately 2" apart.

Shift the carriage control valve to the middle (neutral) position.

Select the heating mode, and adjust the middle pressure reducing valve to its lowest pressure by turning the valve counterclockwise.

Shift the carriage control valve to the left.

Gradually increase the pressure by turning the valve clockwise. Increase the pressure until the carriage moves.

Quickly reduce the heating pressure valve counterclockwise until the carriage is just barely moving.

Record this actual drag pressure.

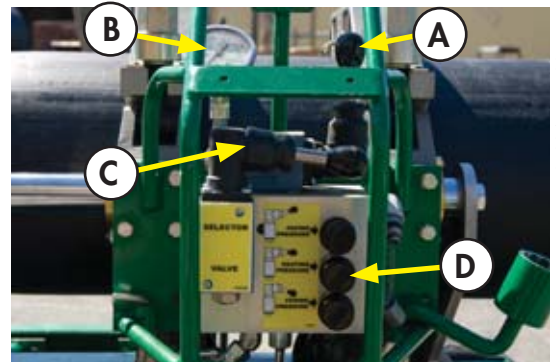

PH01924-1-15-00

- A - Carriage Control Valve
- B - Pressure Gauge
- C - Pressure Selector Valve
- D - Pressure Reducing Valves (3)

TX03023-8-19-09

Set Fusion Pressure

With the selector valve in the down position, the fusion pressure can be set.

The theoretical fusion pressure can be calculated using the enclosed fusion pressure calculator. Always add drag pressure to the theoretical fusion pressure.

Gauge (Fusion) Pressure = Theoretical Fusion Pressure + Drag Pressure



PH04004-8-25-09

TX03024-10-19-10

Check for Slippage

Bring the two sections of pipe together under fusion pressure to make sure they don't slip in the jaws.

If slippage occurs, return to **Loading Pipe into Machine**.

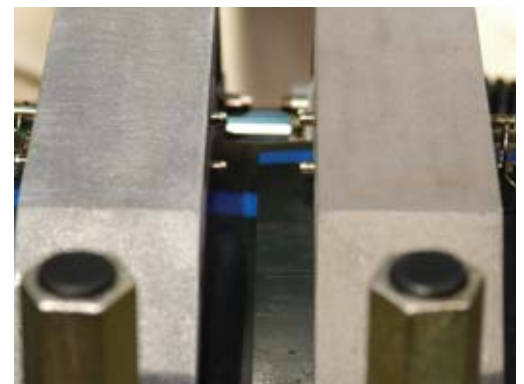

PH04464-1-31-11

TX00971-12-7-10



Check Alignment

Move carriage to the left at facing pressure, until pipe ends contact. Look across the top surface of pipe ends to check alignment. If there is a noticeable step across the joint, adjustments must be made.

WARNING Hydraulically operated equipment is operated under pressure. Anything caught in the machine will be crushed. Keep fingers, feet, arms, legs, and head out of the machine while operated.

If pipe is not lined up, tighten the high side jaw to bring into alignment.

IMPORTANT: Always tighten the side that is higher, never loosen the low side.

When the pipe is properly aligned, ensure all clamp knobs are tight.

NOTICE: When clamping, do not over-tighten the clamp knobs because machine damage can result. Check to see if there is space between the upper and lower jaws. If the two jaws are touching, do not continue to tighten.

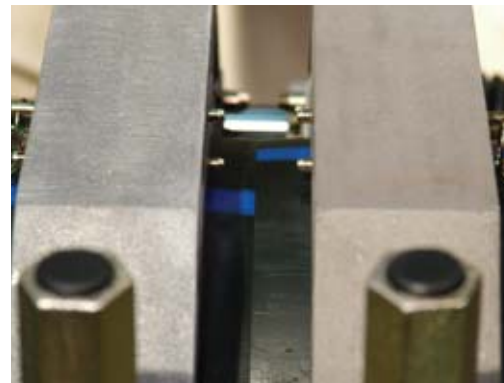

PH04464-1-31-11

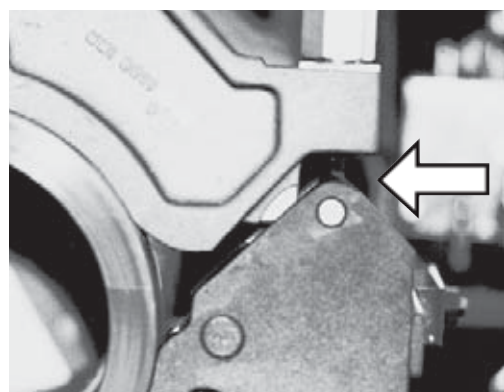

PH00323-9-25-93

TX04263-3-30-11

Position Carriage for Heater Insertion

Move carriage to the right to open a gap large enough to insert the heater.

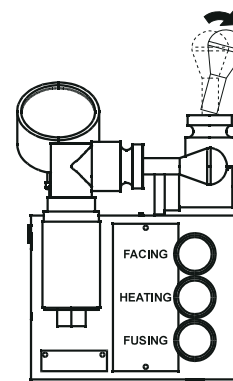

CD001908-2-14-96

TX00374-9-15-94

Check Heater Temperature

NOTICE: Incorrect heating temperature can result in questionable fusion joints. Check heater plates periodically with a pyrometer and make necessary adjustments.

Check heater surface temperature.

Refer to the pipe manufacturer's recommendations or appropriate joining standard for proper heater temperature.



WR00077-4-16-93

TX04248-04-28-14



Inserting Heater

⚠ DANGER

Heater is not explosion proof. Operation of heater in an explosive atmosphere without necessary safety precautions will result in serious injury or death.

If operating in an explosive atmosphere, heater should be brought up to temperature in a safe environment, then unplugged before entering the explosive atmosphere for fusion.

Use a clean nonsynthetic cloth to clean the butt fusion heater surfaces.

Verify heater temperature by noting the reading on the dial thermometer.

Insert heater between the pipe ends.



PH02333-6-28-02

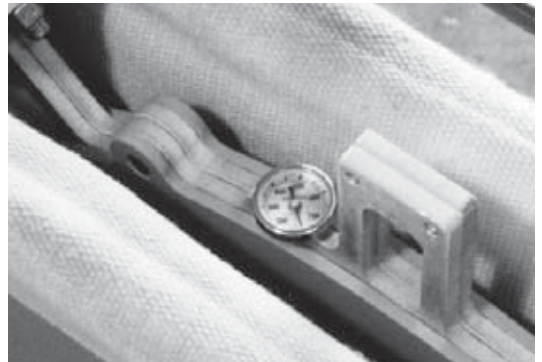

PH01094-2-20-97

TX00377-04-16-14

Heat Pipe

Shift the selector valve (A) to the center position, and set the heating pressure (if required). If heating pressure is not required, set the pressure reducing valve (B) at its lowest setting, or the drag pressure, whichever is higher.

Shift the selector valve (A) to the fusion position and move the carriage control valve (C) to the left to bring pipe ends in contact with the heater. Move selector valve (A) to middle (heating mode) position. If heater pressure is not required by pipe manufacturer or joining standard, or opposing forces are not great enough to move the carriage away from the heater, shift the carriage control valve to neutral.

IMPORTANT: Always shift into the heating mode **before** returning carriage valve to neutral.

Follow the pipe manufacturer's suggested heating and soaking procedure or joining standard.

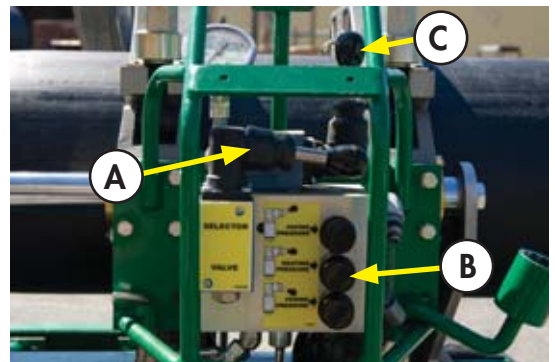

PH04548-5-5-11



PH04465-1-31-11

TX04264-3-30-11

Fusing the Pipe

NOTICE: Failure to follow the pipe manufacturer's heating time, pressure and cooling time may result in a bad joint.

After following the heating procedure, verify carriage control valve is in neutral and move selector valve down, to fusion position.

Move the carriage to the right just enough to remove the heater.

Quickly remove the heater.

Quickly inspect pipe ends for appropriate melt.

When heater is clear of the jaws, quickly move the carriage to the left and bring the pipe ends together using the pipe manufacturer's recommended pressure.

Allow joint to cool under pressure according to pipe manufacturer's recommendations or appropriate joining standard.

Visually examine the entire circumference of the joint for compliance with standards established by your company, customer, industry, federal, state, or local regulations.

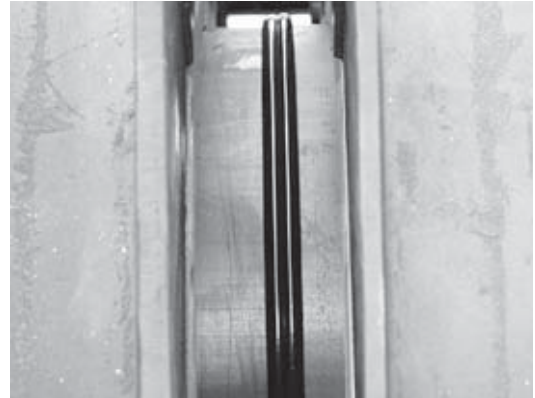

TX04265-1-20-12

Opening Movable Jaws

Shift the carriage control valve to the neutral position.

Loosen all clamp knobs, and move carriage to the right far enough to open the jaw nearest the facer.

Open the movable jaws.



PH04549-5-5-11

TX00380-3-30-11

Opening Fixed Jaws

Open the fixed jaws.



PH02580-09-18-03

TX00381-9-16-94



Operation



Raise Pipe

Raise the joined pipe using the hydraulic pipe lift.

TX00818-12-21-95



PH02575-09-18-03

Position Pipe for Next Joint

Move the fusion machine to end of pipe, or pull the pipe through the jaws until the end of the pipe is protruding more than 1" past the jaw face of the fixed jaw.

TX01091-8-20-96

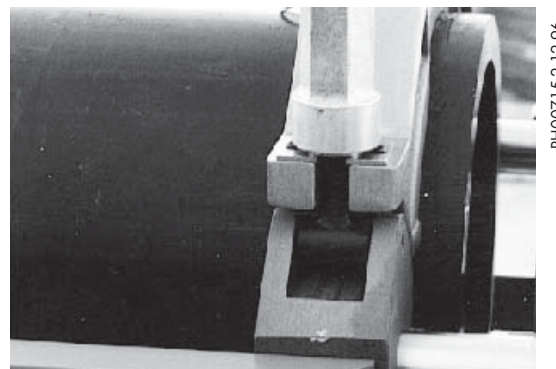

PH00715-2-12-96

Install Next Piece of Pipe

Insert a new piece of pipe in movable jaws and repeat all previous procedures.

TX00384-10-12-95



PH02577-09-18-03



Remove Facer From 412 and 618 Machine

Remove rear guide rod bracket.



Support the facer with a person or sling so it does not fall once the facer locking bolts are removed.

Remove facer locking bolts.



Lift facer out of the carriage and set on cardboard or wood blocks off of ground.

Attach rear guide rod bracket in the position shown.





Remove Carriage Assembly from the Chassis



This equipment is not explosion proof. Operation of this equipment in an explosive atmosphere without necessary safety precautions will result in serious injury or death. See safety section.

There are two sets of hydraulic hoses. One set connects to the carriage hoses on the machine and to the carriage. The other set connects to the facer hoses on the machine and to the facer.

Disconnect both sets of hoses.

The carriage can be easily removed from the machine for fusing pipe on the ground or in the ditch. For especially tight conditions it is also possible to remove the outer fixed jaws and skid. The facer can be removed from the pivot shaft and used manually.

To remove the carriage, pull the pin at the rear of the machine and slide the carriage forward approximately one inch.

Attach lifting sling to the lifting points and the manifold bracket, then lift the carriage assembly.



PH02578-09-18-03



PH01941-11-15-00

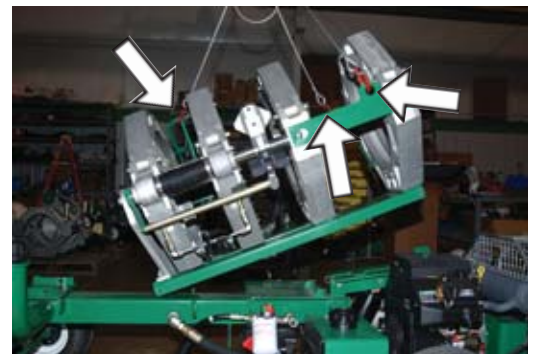

PH02586-09-18-03



Remove 3-Jaw Assembly from the Carriage

Remove braces from inner fixed jaw.



PH01939-11-15-00

Remove the four bolts holding carriage assembly to the chassis with the wrench provided.



PH01945-11-15-00

Attach lifting strap as shown and lift the carriage assembly.



PH01947-11-15-00

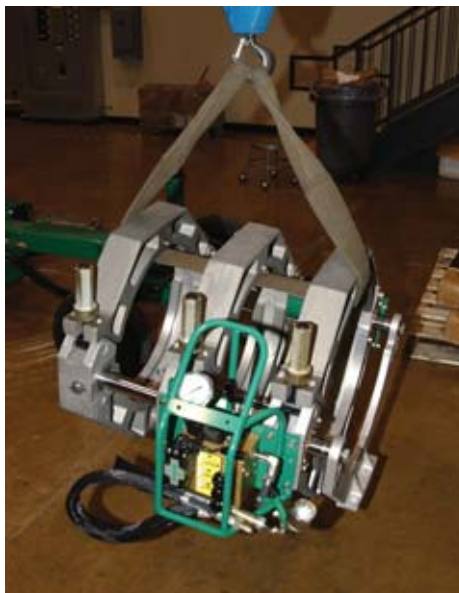

PH02591-09-18-03

TX01875-11-8-00

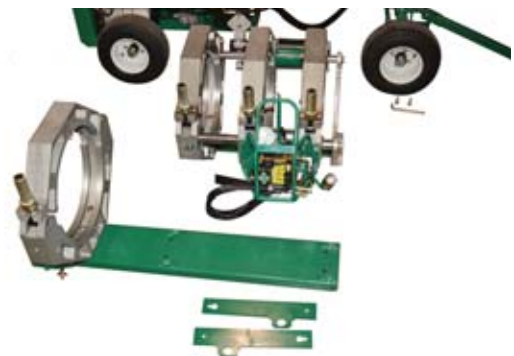

PH02592-09-18-03



Manual Facer Operation

Lift as shown.



PH019388-11-15-00

Lock onto back guide rod, then latch on front guide rod.

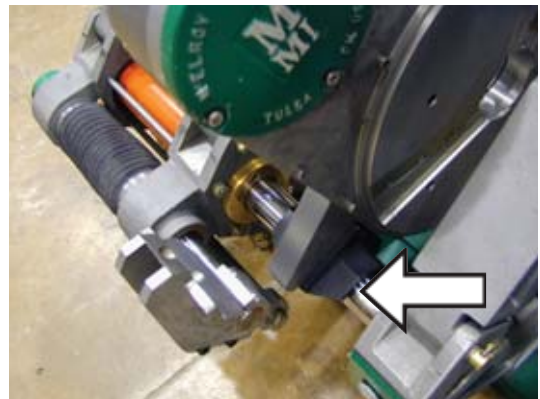

PH01946-11-15-00

TX01887-11-15-00

Outrigger

The outrigger is an arm that is retractable and adds support to the carriage assembly when opening the jaws and pivoting the facer away from the carriage.

To extend or retract the outrigger, press the locking button near the base of the outrigger and push or pull the arm until the button snaps to the locked position.

NOTICE: Never use the outrigger to lift or move the carriage.

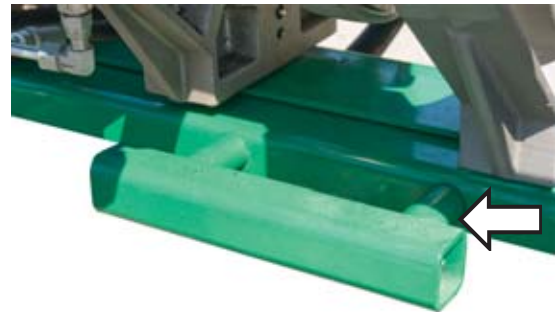

PH04550-5-11



PH04551-5-5-11

TX02304-04-29-04

Removing Top Jaws

If the carriage is going to be hand carried, or if the carriage needs to be hoisted and slid underneath the pipe, the top jaws need to be removed.

Loosen all clamp knobs. Take out the detent pins securing the top jaws and remove the jaws.

TX01479-2-26-98

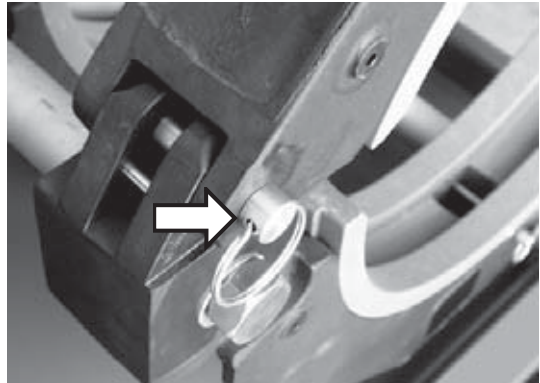

PH01305-3-12-98

Lower 3-Jaw or 4-Jaw Carriage into Ditch

Use all 4 jaws whenever possible. The three jaw unit should be used only when space is not available for the entire carriage, such as fusing onto a tee, an ell or doing saddle fusion.

4-Jaw

Attach lifting sling to the manifold bracket and the near side lift point.

Lift carriage assembly and lower into ditch.

3-Jaw

Attach lifting sling to the manifold bracket.

Lift carriage assembly and lower into ditch.



PH01983-1-15-00



PH01984-1-15-00

TX01864-9-29-00



Clamp Carriage Assembly To Pipe

Position carriage assembly on side of the pipe. Lift pipe and slide carriage assembly under pipe.

Rotate carriage assembly around to a normal upright position.

Attach the top jaws and clamp around pipe.

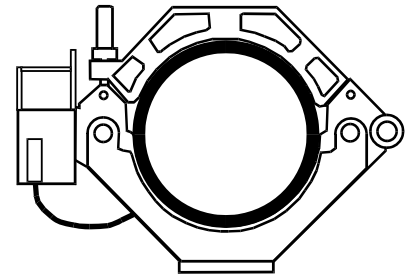
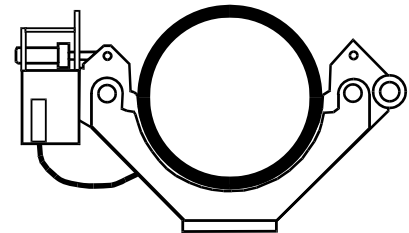
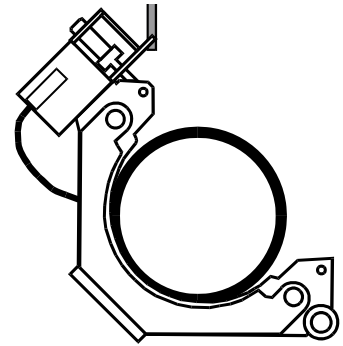

CD00193B-2.19-96

CD00194B-2.19-96

CD00195A-2.19-96

TX00879-2.19-96



Lower Facer Into Ditch

Attach lifting sling to the large upper handle on facer and lower into position and reattach.

TX02222-09-18-03



PH0258409-18-03

Attach Hydraulic Hoses

There are two sets of hydraulic extension hoses. One set connects to the carriage hoses on the machine and to the carriage. The other set connects to the facer hoses on the machine and to the facer.

Connect all hoses.

TX01485-2-26-98



PH01908-11-15-00

Make Fusion Joint

Refer to the "Butt Fusion Procedure" for operating instructions.
After facing operation, remove the facer from ditch.

TX00450-9-16-94

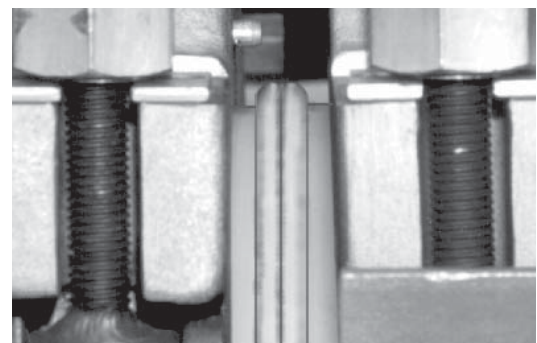

PH00363B-9-12-94

Remove Carriage Assembly From Ditch

Loosen clamp knobs and remove top jaws.

Rotate carriage assembly from under the pipe.

IMPORTANT Always rotate unit with valve system facing up to protect against damage.

Attach sling to lifting point.

Lift carriage assembly from ditch.

TX00451-9-16-94

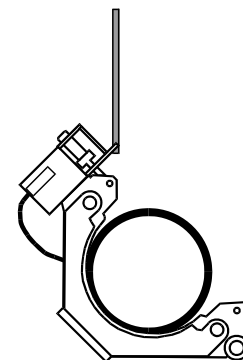

CD00193B-2-19-96



Reassemble Fusion Machine

Bolt carriage assembly to the chassis and replace standard hoses.

Lift facer into position and bolt to facer mount. Do not tighten.

Pivot facer down and bring jaws inward against the facer to establish facer position. Open jaws away from facer and pivot facer out.

Tighten the facer mounting bolts.

Replace facer hoses.

Replace top jaws.



PH02582.09-18.03

TX00452-5-5-11



Lifting Fusion Machine



Lifting Safety

Follow all applicable federal, state, local, and industry specific regulations when lifting.

⚠ WARNING

Safety warnings:

1. Do not exceed rated load or lift loads greater than the rated load rating of the lifting device.
2. Do not operate a damaged or malfunctioning device.
3. Do not lift persons.
4. Do not lift a suspended load over persons.
5. Do not leave a suspended load unattended.
6. Do not remove or obscure warning labels.
7. Read and understand the operator's manual before using the device.
8. Stay clear of the suspended load.
9. Lift loads only as high as necessary.
10. Do not alter or modify the lifting device.
11. Employ generally accepted safe lifting practices.
12. Do not shock or impact load the lifting device.
13. Inspect all lifting pins for damage.

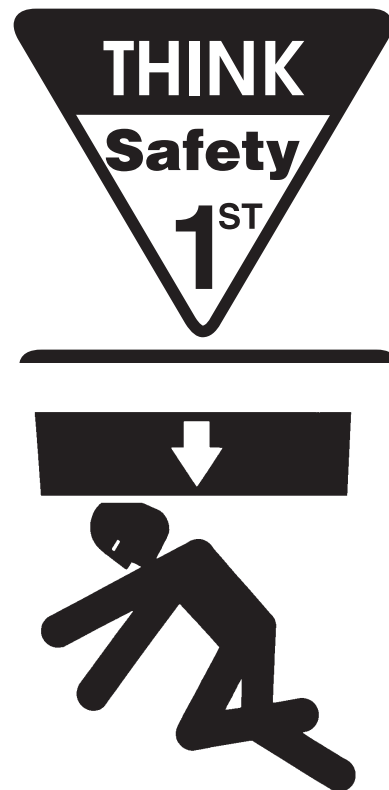

SAFE1st-12-14-92

WR00014-3-8-93



Lifting Fusion Machine



Lifting Sling

A special lifting sling is shipped with each machine. There are two lifting eyes on each side of the chassis frame. Attach all four hooks on the lifting sling to the lifting eyes.

TX01264-2-20-97

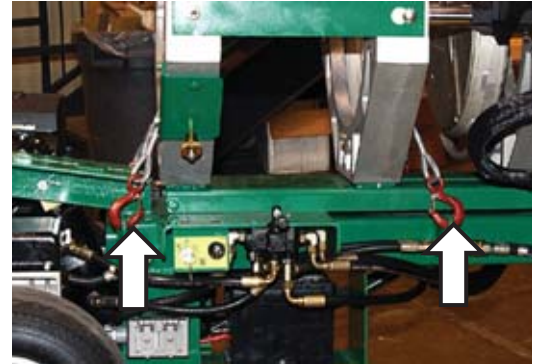

Lift Equipment

Using proper overhead rigging and equipment of adequate load rating, lift the fusion unit.

See the Specification Section for the weights of your fusion machine.

TX00900-3-25-96





Maintenance



Preventative Maintenance

To insure optimum performance, the machine must be kept clean and well maintained.

With reasonable care, this machine will give years of service. Therefore, it is important that a regular schedule of preventive maintenance be kept.

Store machine inside, out of the weather, whenever possible.

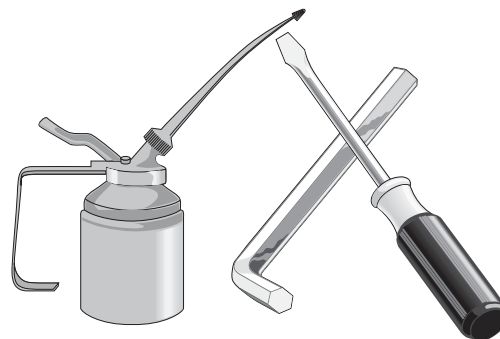

CD00142-11-2-94

TX00428-8-10-95

Washing the Machine

The machine should be cleaned, as needed with a soap and water wash.

Do not pressure wash.

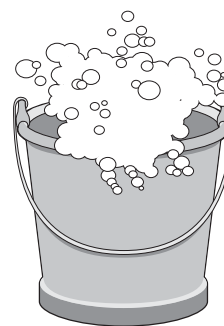

CD00178-9-15-95

TX00429-04-28-14

Check Hydraulic Fluid

The hydraulic fluid level should be checked daily.

If hydraulic fluid is not visible in the sight gauge, fluid must be added.

Refer to the "Hydraulic Fluids" section of this manual for hydraulic fluid recommendations.

If fluid is not visible in the sight gauge, fill reservoir until fluid is visible in the sight gauge. Do not overfill reservoir as the fluid will expand as it heats up.

Never allow dirt, water or other foreign matter to enter the tank.

Use only clean fluid from an unopened container.

TX00430-04-28-14



PH02602-09-18-03

Change Hydraulic Fluid and Filter

The hydraulic fluid and filter should be replaced when the filter pressure gauge indicates "service filter".

Fluid should also be changed as extreme weather conditions dictate.

Refer to the "Hydraulic Fluids" section of this manual for hydraulic fluid recommendations.

TX02140-04-28-14



PH02603-09-18-03



Maintenance



Check Gauge

The gauge should read zero when the unit is not running.
Damaged gauges should be replaced.

TX02291-3-8-04



PH01972-11-15-00

Clean Jaws and Inserts

To prevent slippage and insure proper alignment, the jaws and inserts must be clean.
Clean the jaws and inserts of any dirt or residual material using a stiff-bristled brush.

TX00433-9-15-94



PH02687-3-8-04

Clean Thrust Bearings

The thrust bearings located in the clamp knobs must turn freely.
Wash the clamp knob bearing assembly with a solvent, and then lubricate with 30W or lighter oil.

TX00434-9-13-94

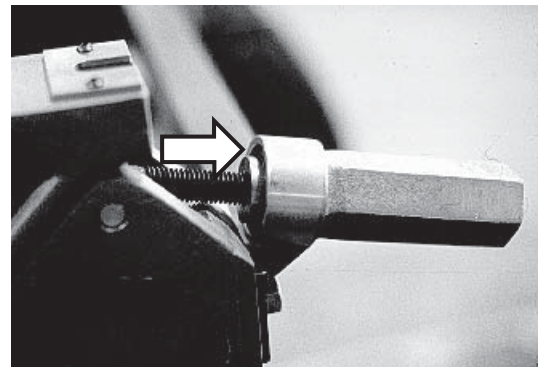

PH00732-3-1-96

Clean Eyebolt Threads

Keep the clamp knob eyebolt threads brushed clean.

TX00435-9-13-94

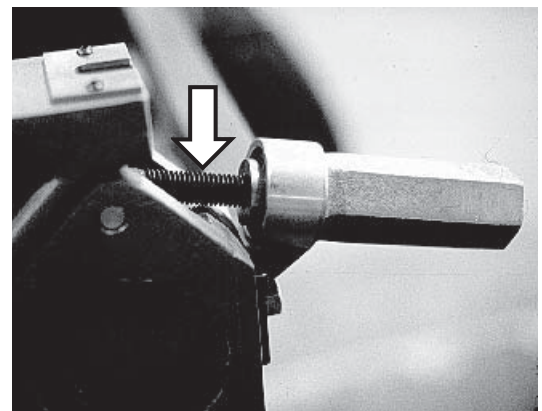

PH00732-3-1-96

Bleeding Air From Hydraulic System

The two carriage cylinders have air bleed **screws** and must be bled if the system ever runs low on oil or leaks air on inlet side of pump. Air in the system is indicated when carriage movement becomes jerky and erratic. To bleed the system, proceed as follows:

Tilt machine so the fixed jaw end is higher than the opposite end. Shift the directional control and move the carriage to the fixed jaw end. Adjust the pressure to approximately 50-100 psi before proceeding.

Loosen the bleed plug on one cylinder next to the fixed jaw.

Hold pressure on the cylinder until no air is indicated and quickly tighten the plug.

Repeat this operation on the opposite cylinder.

Tilt the machine so the opposite end is higher than the fixed jaw end. Move the carriage to the end opposite the fixed jaw and repeat the above procedure on the this end of the cylinders.

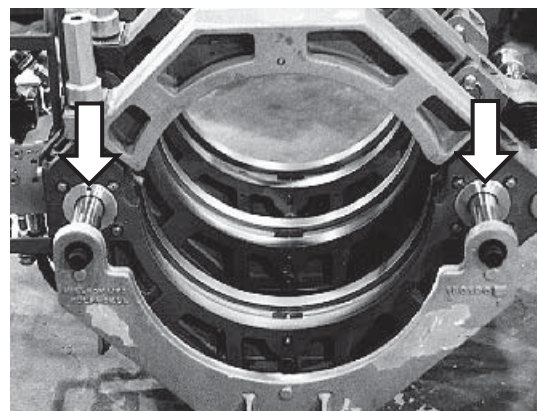

PH007202-16-96

TX00877-2-16-96

Facer Blades

Blades bolt directly to the blade holder and should be inspected for damage and sharpness.

Dull or chipped blades must be replaced.

NOTICE: Never extend the blade beyond the inner or outer circumference of the facer.

TX02475-3-29-05



PH01912-11-15-00

Clean Heater Surfaces

The heater faces must be kept clean and free of any plastic build up or contamination.

Before each fusion joint the heater surfaces must be wiped with a clean, non-synthetic cloth.

NOTICE: Do not use an abrasive pad or steel wool. Use a non-synthetic cloth that won't damage surfaces.

CAUTION The heater is hot and will burn clothing and skin. Keep the heater in its insulated heater shroud when not in use, and use care when heating the pipe.



PH02333-7-08-02

TX00440-3-30-11



Installing Butt Fusion Heater Plates

Coated butt fusion heater plates are available for all non-coated heaters.

Butt fusion heater plates are installed with stainless steel cap screws.

Install butt fusion heater plates while the heater is cool.

Care should be taken to assure that the butt fusion heater plates are seated on the heater body, and that there is no foreign matter trapped between these surfaces.

IMPORTANT: Do not over tighten the bolts.

The surface of the butt fusion heater plates are coated with an antistick coating.

TX02716-11-30-10



PH02333-7-08-02

Adjusting Heater Temperature

Turn knob to desired temperature. Measure the heater surface temperature with a pyrometer. Any variance must be corrected to the pyrometer reading.

Loosen setscrew in the knob. Turn knob to point to the same temperature as the pyrometer. Tighten setscrew in the knob.

Turn knob to desired temperature. Allow heater to stabilize at the new temperature (5 to 10 minutes) after adjusting.

The thermometer on the heater body indicates internal temperature and should be used as a reference only.

TX02030-6-28-02



PH02313-6-28-02

Heater Indicator Light

The heater has a green indicator light which will flash on and off. This indicates that the controller is operating normally. If the green indicator is not flashing then the controller may not be operating properly. If this occurs, disconnect power and have the heater repaired by an McElroy Authorized Service Center.

The heater has a red indicator light on the handle at the bottom of the temperature scale. When the heater is plugged in and preheating the red light glows steadily until the set temperature is reached. The red light then goes off and on as the heater maintains temperature.

If the heater is not operating properly, the control will attempt to turn the heater off and the red indicator light will flash rapidly. If this occurs, disconnect the power and take it to a McElroy Authorized Service Center for repair.

TX04036-4-12-10



PH02314-6-28-02

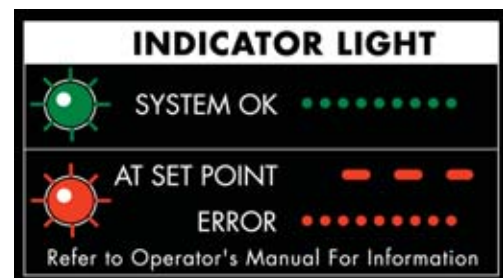

PH02571-09-18-03



Fasteners Must Be Tight

Check all nuts, bolts, and snap rings to make certain they are secure and in place.

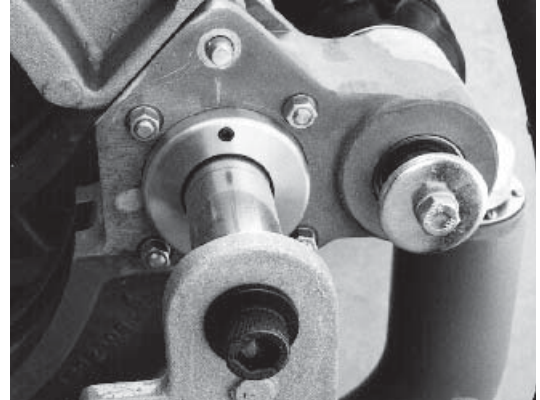

PH00731-2-22-96



PH02583-09-18-03

TX00437-9-13-94



Maintenance Checklist



Fusion Machine Checklist

Item to Check	Satisfactory	Needs Repair	Repair Comments
Machine is clean			
All pins and snap rings are in place			
All nuts and bolts are tight			
All placards and handles are in place			
All safety labels and decals are in place			
All clamp knobs turn freely			
Cords and plugs are in good condition			
All hardware is on the basic machine			
Oil reservoir is filled to correct level			
Machine is free of hydraulic leaks			
Hydraulic gauge reads correctly			
Brake functions properly			
Tire pressure is correct			
Jaws are properly aligned			
Facer pivot operates properly			
Facer operates smoothly			
Face-off is square			
Inserts fit and pin properly			
Primary pump pressure can be adjusted from 500 psi to 1000 psi			
Voltage to electrical models and heaters is 240V			
Carriage and Selector Valves operate smoothly			
Pressure Reducing Valves operate in their range			
Filter gauge reads correctly			
HEATER			
Heater surface is clean and in good condition			
Thermometer is in good working order			
Surface temperature checked with pyrometer			
Check receptacles for damage			



Determining Fusion Pressure



Variable Definitions

- O.D. = Outside Diameter
- t = Wall Thickness
- Π = 3.1416
- SDR = Standard Dimensional Ratio
- IFP = Manufacturer's Recommended Interfacial Pressure
- TEPA = Total Effective Piston Area

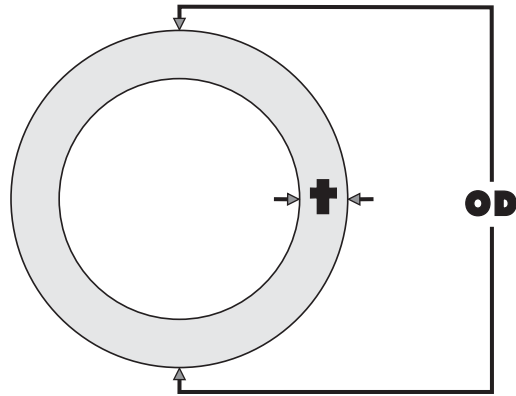

Formulas

$$t = \frac{\text{O.D.}}{\text{SDR}}$$

$$\text{AREA} = (\text{O.D.} - t) \times t \times \Pi$$

$$\text{FORCE} = \text{AREA} \times \text{IFP}$$

$$\text{GAUGE PRESSURE} = \frac{(\text{O.D.} - t) \times t \times \Pi \times \text{IFP}}{\text{TEPA}} + \text{DRAG}$$

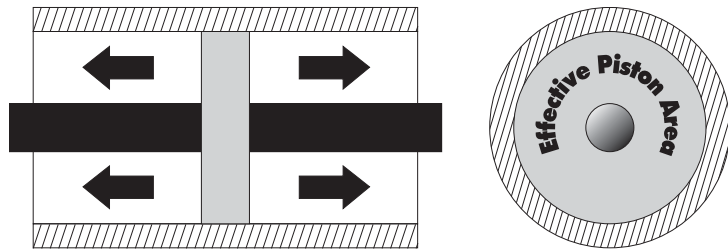

Example

Pipe Size = 8" IPS

O.D. of Pipe = 8.625

DRAG = as measured in PSI (for this example use 30 PSI)

SDR of Pipe = 11

Recommended Interfacial Pressure = 75 PSI

Using a Model 28 Fusion Unit

$$t = \frac{\text{O.D.}}{\text{SDR}} = \frac{8.625}{11} = 0.784$$

TEPA = 4.710 (From Table)

$$\text{GAUGE PRESSURE} = \frac{(\text{O.D.} - t) \times t \times \Pi \times \text{IFP}}{\text{TEPA}} + \text{DRAG}$$

$$\text{GAUGE PRESSURE} = \frac{(8.625 - .784) \times .784 \times 3.1416 \times 75}{4.710} + 30 \text{ PSI} = 338 \text{ PSI}$$

Total Effective Piston Areas

Fusion Model	High Force (Standard)	Medium Force (High Velocity)	Low Force (Extra High Velocity)
28	4.710	-	1.66
412	11.775	6.013	3.142
618	11.775	6.013	3.142
824	29.44	15.32	9.425
1236	29.44	15.32	9.425
1648	31.42	14.14	-
2065	31.42	-	-
1600mm	31.42	14.14	-



Hydraulic Fluids



Hydraulic Fluids

The use of proper hydraulic fluid is mandatory to achieve maximum performance and machine life. Use a clean, high quality, anti-wear hydraulic fluid with a viscosity index (VI) of 135 minimum. It should have a maximum viscosity of 500 cSt (2000 SSU) at startup (ambient temperature) and a minimum viscosity of 13 cSt (65 SSU) at the maximum fluid temperature (generally 80°F above ambient). Using hydraulic fluids that do not meet these criteria may cause poor operation and/or damage to the hydraulic components.

The following table specifies the fluid temperature at various viscosities. Temperature rise of the hydraulic fluid can vary from 30° F to about 80° F over the ambient temperature depending on the pressure setting, age of the pump, wind, etc. Mobil Unavis N46 hydraulic fluid is installed at our factory. The advantage of this fluid is a wider temperature range, however, this fluid should not be used for continuous operation below 24°F.

NOTE: The Mobil DTE 10 Excel series replaced the DTE 10M Series. The Exxon Unavis N series are now Mobil Unavis N.

Hydraulic Fluids Characteristics																	
Manufacturer	Fluid Name	cSt 100F	cSt 210F	V.I.	-20F	-10F	0F	10F	30F	50F	70F	90F	110F	130F	150F	Range °F	Range °C
Mobil	10 Excel 15	15.8	4.1	168	*****	*****	*****	*****	*****	*****	*****	*****	*****	*****	*****	-16 - 113	-27 - 45
	10 Excel 32	32.7	6.6	164				*****	*****	*****	*****	*****	*****	*****	*****	12 - 154	-11 - 68
	10 Excel 46	45.6	8.5	164				*****	*****	*****	*****	*****	*****	*****	*****	23-173	-5 - 78
	10 Excel 68	68.4	11.2	156				*****	*****	*****	*****	*****	*****	*****	*****	37-196	3 - 91
	Unavis N-32	34.9	6.9	164				*****	*****	*****	*****	*****	*****	*****	*****	12-150	-11 - 66
	Unavis N-46	46	8.5	163				*****	*****	*****	*****	*****	*****	*****	*****	24-166	-4 - 74
	Unavis N-68	73.8	12.1	160				*****	*****	*****	*****	*****	*****	*****	*****	39-193	4 - 89

TX03082-2-26-14

NOTE: This chart is based on pump manufacturer recommendations of 13 to 500 cSt.

NOTE: Temperatures shown are fluid temperatures. – NOT ambient temperatures.

Model 412

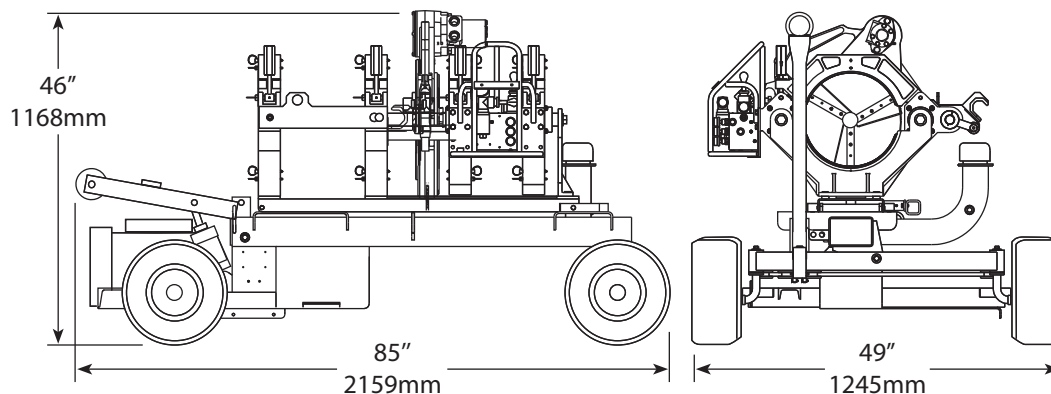

Dimensions

Width: 49" (1245 mm)
 Length: 85" (2159 mm)
 Height: 46" (1168 mm)

Weight

412: 1225 lbs (556 Kg)
 412E: 915 lbs (415 Kg)
 Facer: 62 lbs (28.1 Kg)
 Heater: 24 lbs (10.9 Kg)
 Carriage: 3000 W, 240 V, single phase AC only, 60 Hz (50 Hz)
 359 lbs. (163 Kg)

Engine

Engine: 18HP Air Cooled V-Twin
 Fuel Capacity: 5 Gallons (18.92 liters)

Electric Model 412E

Minimum Power Requirement: 5.5 kW/6.5 kVA
 3 Phase, 240 V, 60 Hz (50 Hz)

Hydraulics

Reservoir Capacity: 6 Gallons (22.71 Liters)
 Hydraulic Fluid: See "Hydraulic Fluids" section for fluid recommendations
 Tire Pressure: 70 psi



Specifications



Model 618

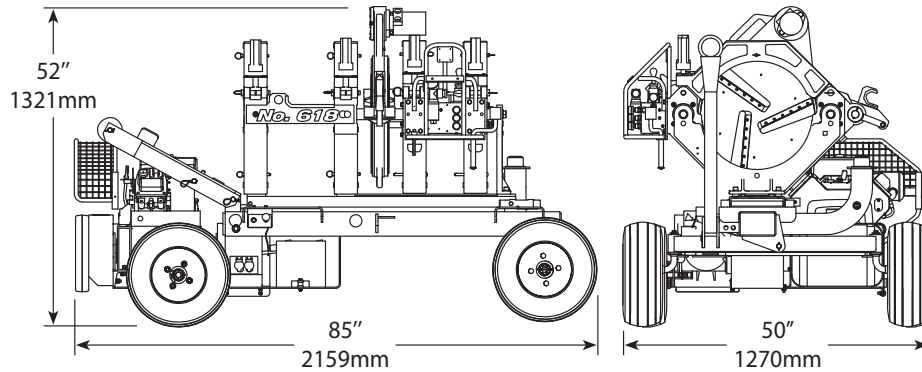

Dimensions

Width:	50" (1270 mm)
Length:	85" (2159 mm) Gas 83" (2108 mm) Electric
Height:	52" (1321 mm)

Weight

618:	1335 lbs (606 Kg)
618E:	1100 lbs (498 Kg)
Facer:	91 lbs (41.3 Kg)
Heater:	6-12" Assembly 28 lbs. (13 Kg) 12-18" Assembly 34 lbs. (15.4 Kg)
Carriage:	3000 W, 240 V, single phase AC only, 60 Hz (50 Hz) 445 lbs. (202 Kg)

Engine

Engine:	18HP Air Cooled V-Twin
Fuel Capacity:	5 Gallons (18.92 liters)

Electric Model 618E

Minimum Power Requirement:	7.5 kW/6.5 kVA 3 Phase, 240 V, 60 Hz (50 Hz)
----------------------------	---

Hydraulics

Reservoir Capacity:	6 gallons (22.71 Liters)
Hydraulic Fluid:	See "Hydraulic Fluids" section for fluid recommendations
Tire Pressure:	70 psi

TX02220-04-28-14



Specifications



Generator Sizing Form

Complete this form and provide a copy to your generator supplier. This information will enable your generator supplier to correctly size a generator for your application.

Motor: _____ 3.0 Horsepower for Model 412E
5.0 Horsepower for Model 618E

Motor Code Letter: H (from motor nameplate)

Motor Voltage: 240 VAC

Motor Phases: 3 Delta

Motor Frequency: _____ (50 or 60 Hz)

Heater Wattage Rating: 3000 Watts resistive

Heater Voltage: 240 VAC

Operational Altitude Range: _____ to _____

Ambient Temperature Range: _____ to _____

Duty Cycle: Standby (Not continuous 24 hours/day)

Allowable Voltage Dip: 20%

Allowable Frequency Dip: 5%

Starting Load Application: Simultaneous turn-on of both motor and heater.

Running Load: Motor continuous, heater cycling on and off at approximately 5 minute intervals.

Fuel: _____ (Gasoline or Diesel)

Special requirements for customer application: _____

About this manual . . .

McElroy Manufacturing continually strives to give customers the best quality products available. This manual is printed with materials made for durable applications and harsh environments.

This manual is waterproof, tear resistant, grease resistant, abrasion resistant and the bonding quality of the printing ensures a readable, durable product.

The material does not contain any cellulose based materials and does not contribute to the harvesting of our forests, or ozone-depleting constituents. This manual can be safely disposed of in a landfill and will not leach into ground water.

TX001660-8-19-99



The leader by design.

P.O. Box 580550 Tulsa, Oklahoma 74158-0550, USA
www.mcelroy.com