

bryant

Day & Night

PAYNE

troubleshooting guide

355MAV

VARIABLE-SPEED 2-STAGE ELECTRONIC CONDENSING FURNACE

Cancels: New

SM05-2
4-95

INDEX

	PAGE
Instructions	1
Example	1
Sequence of Operation.....	2-4
Self-Test Mode.....	2
Heating Mode.....	2
Heating Mode-Two Stage.....	2
Emergency Heat Mode.....	2-3
Cooling Mode	3
Heat Pump Mode.....	3
Continuous Fan Mode.....	3-4
Component Test.....	4
Bypass Humidifier Mode.....	4
Dehumidification Mode.....	4
Zone Mode.....	4
Start Here.....	5
Service Label/Fault Code Instructions	6-7
Improper Operation With No Flashing Fault Code.....	8
Not Enough Cooling Airflow	9
High-Fire Temperature Rise Too Low (Cold Blow).....	10
LEDs 1, 2, 3, or 4 On Solid.....	10-11
RED LED2 Flashing	11
Fault Code 11—No Fault in Recent History Display	12
Fault Code 12—Blower Calibration Lockout.....	12-14
Fault Code 13—Limit Switch Lockout.....	14-15
Fault Code 14—Ignition Lockout.....	16
Fault Code 21—Invalid Model Selection.....	17
Fault Code 22—Set Up Error.....	17
Fault Code 23—Invalid Blower Airflow Selection.....	18-19
Fault Code 24—Secondary Voltage Fuse Is Open.....	19-20
Fault Code 31—High-Pressure Switch Fault.....	20-22
Fault Code 32—Low-Pressure Switch Fault	22-24
Fault Code 33—Limit Switch Fault.....	24-25
Fault Code 34—Ignition Proving Fault	25-26
Fault Code 41—Blower Outside Valid Speed Range.....	26-27
Fault Code 42—Inducer Outside Valid Speed Range.....	27-29
Fault Code 43—Pressure Switch Calibration Fault.....	29-30
Fault Code 44—Blower Calibration Fault.....	30-31
Cleanup and Start-Up Instructions	31

APPENDIX A—Board Layout & Wiring Schematic	32-33
APPENDIX B—Isolation Circuits	34
APPENDIX C—Pressure Check Diagram.....	34
APPENDIX D—Quick Motor Test Procedure.....	35-37
APPENDIX E—Variable-Speed Condensing Furnace Duct Static and Blower Operation.....	38-42
APPENDIX F—Quick Reference Information	43
APPENDIX G—Thermostat Staging Algorithm	44-45

INSTRUCTIONS

This guide uses your expertise and observations to lead you to the trouble spot as efficiently as possible. This is only intended as a guide and should not be used blindly. Your experience and expertise are of high value when troubleshooting this unit. Do not disregard all of your instincts.

The microprocessor furnace control was designed with diagnostic capabilities built in. LEDs are used to flash a fault code which will lead you to 1 of the subsections as listed in the Index.

You should **ALWAYS** begin in the **START HERE** subsection (see Index for page number) which will guide you to the appropriate subsection where a minimal number of steps will be used to correct the problem. If you are very experienced at how this furnace operates and you suspect the problem is either the blower motor, inducer motor, or furnace control board, you can use the quick motor test procedure at the end of the troubleshooting guide to isolate the problem or direct you to appropriate section in main troubleshooting guide.

Once in a subsection, read the statement or question. A statement will have a number in the "GO TO" column. Do whatever the statement says, then proceed to step indicated in the "GO TO" column.

If the step is a question (a question will have a number in the "YES" or "NO" column), answer it "YES" or "NO." If the answer is "YES," go to step indicated in "YES" column. If the answer is "NO," go to step indicated in "NO" column.

Let's try our guide out using the **EXAMPLE** section below, and see how it works. Suppose that the problem is a defective low-pressure switch (for example will not make). This is an internal problem and cannot simply be seen. We go to the **START HERE** section to Step 1.

EXAMPLE START HERE SECTION

STEP		YES	NO	GO TO
1.	Step 1 tells us to record status of LEDs 1-4 and go to Step 2.	—	—	2
2.	Step 2 asks the question, "Are any LEDs flashing?". If low-pressure switch was defective, a low-pressure switch fault code would be flashing, so the answer is "YES." We go to Step 5.	5	3	—
5.	Step 5 asks the question, "Is RED LED2 flashing?". If low-pressure switch was defective, a low-pressure switch fault code would be flashing, so the answer is "NO". We go to Step 7.	6	7	—
7.	Step 7 tells us to go to low-pressure switch fault subsection.	—	—	INDEX

SEQUENCE OF OPERATION

 **CAUTION:** Furnace control must be grounded for proper operation, or control will lock out. Control is grounded through green wire routed to gas valve and burner box screw.

Using schematic diagram (see Appendix A), follow sequence of operation through different modes. This furnace has a new control system. Read and follow wiring diagram carefully.

NOTE: If 115-v power supply to furnace or blower access panel switch is interrupted during a call for heat, blower operates at low-heat speed for 60 sec when power is restored before heating cycle is resumed.

I. SELF-TEST MODE

The control center goes through a brief self test whenever 115-v or 24-v power is interrupted. The self test takes approximately 2 sec to complete. After power is restored, red (microprocessor) LED briefly comes on. Then green LED comes on for 1 sec, followed by 1 sec where both yellow and green LEDs are on. During this time, the microprocessor is checking itself.

II. HEATING MODE

When thermostat calls for heat, R-W/W1 circuit closes.

1. **Prepurge period**—The inducer motor is turned on and slowly comes up to speed. When low-pressure switch closes, inducer motor RPM is noted by microprocessor, and a 25 sec prepurge period begins. The RPM is used to evaluate vent system resistance. This evaluation is then used to determine required RPM necessary to operate inducer in low-heat mode.

NOTE: The heat cycle can start in either high or low heat. If a high-heat cycle is initiated, the inducer continues increasing its speed after low-pressure switch closes. When high-pressure switch closes, inducer motor RPM is noted by microprocessor before the 25 sec prepurge period begins. The RPM is used to evaluate vent system resistance. This evaluation is then used to determine required RPM necessary to operate inducer in high-heat mode.

2. **Humidifier (HUM)**—The HUM terminal is energized whenever the inducer prepurge period is completed.
3. **Ignitor warm up**—At end of prepurge period, the hot surface ignitor (HSI) is energized for a 17-sec HSI warm-up period.
4. **Ignition sequence**—After HSI ignitor warm-up period is completed, the gas valve opens, permitting gas flow to burners where it is ignited. After 5 sec, the HSI is de-energized and a 2-sec flame-sensing period begins.

NOTE: The initial heat mode after 115-v or 24-v power interruption will be LOW HEAT. Low heat remains energized for 16 minutes before high heat is initiated, providing thermostat is still calling for heat.

After the initial cycle, the microprocessor evaluates the length of low- and high-heat operating times and calculates optimum length of low and high heat for next heat cycle. This accommodates the heat load requirement seen as a result of thermostat operating time. See Appendix G for details on thermostat staging algorithm.

5. **Flame sensing**—When burner flame is sensed, the control center holds gas valve open and begins blower on delay period.

NOTE: Ignition sequence repeats 3 additional times before a lockout occurs. Lockout automatically resets after 3 hr, or can be manually reset by turning 115-v or 24-v power off (not at thermostat) for 3 sec minimum, then turning on again.

6. **Inducer speed reduction**—If cycle starts in low heat, inducer speed reduces slightly after the flame sense. If cycle starts in high heat, inducer speed increases 15 sec after flame sense. The reduction in speed in low heat is to optimize combustion for maximum efficiency.

7. **Blower on delay**—The blower starts 60 sec after flame sense if cycle started in low heat or 35 sec after flame sense if cycle started in high heat.

NOTE: The blower starts at approximately 400-500 RPM. After 20 sec, the motor is turned off for 1/10 of a sec where a coast down calibration is done to evaluate resistance of the conditioned air duct system. The microprocessor then determines blower RPM required to provide proper airflow for heating mode.

8. **Electronic Air Cleaner**—The EAC-1 terminal is energized whenever the blower operates.
9. **Blower off delay**—When thermostat is satisfied, the R-W/W1 signal is terminated, de-energizing gas valve (stopping gas flow to burners) and HUM terminal is de-energized.

The blower reduces its speed to low-heat RPM. The blower and EAC remain operating 90, 135, 180, or 225 sec (depending on blower off time selection). The furnace is factory set for a 90 sec blower off delay.

10. **Post purge**—The inducer continues operating for 15 sec after gas valve is de-energized.

III. HEATING MODE—TWO STAGE

The control center provides 2-stage heating using a single-stage thermostat. The control center maximizes comfort while optimizing efficiency to meet the demands of the conditioned area when a thermostat R-W/W1 signal is received.

If thermostat control over furnace staging is desired, a 2-stage thermostat can be used. When control center receives a thermostat R-W/W1 and R-W2 signal, high heat is energized and when R-W/W1 signal is received, low heat is energized. This method overrides microprocessor control of high or low heat.

NOTE: When using 2-stage thermostat operation with R-W/W1 and R-W2 signals, setup switch SW-2 MUST be in ON position. The heat cycle operates as stated in Heating Mode section.

To allow for greater comfort, a 2-stage thermostat control is recommended when zone systems are used.

IV. EMERGENCY HEAT MODE

NOTE: The furnace should not be operated in emergency heat mode for extended periods of time. Operation is only recommended to provide heat until replacement components can be obtained or fault resolved.

In this mode, the microprocessor is bypassed and the motors operate at full speed with high-heat operation. The heat exchangers, motors, and electronics can be overstressed and may reduce the life of the components if operated for an extended period.

NOTE: No safeties are bypassed when using emergency heat mode.

Emergency heat mode can be selected using setup switch SW-4. SW-4 should be used when a fault condition exists or difficult to resolve problems occur. This allows heating until the fault can be corrected.

In emergency heat mode, the normal heat mode outlined in Heating Mode section is not followed. The following sequence will occur:

When thermostat calls for heat, the R-W/W-1 circuits close.

1. **Prepurge period**—The inducer motor is turned on IMMEDIATELY operating at maximum speed, closing low- and high-pressure switches. Prepurge begins 25 sec after high-pressure switch closes.
2. **Blower on**—The blower motor is turned on IMMEDIATELY and slowly increases to maximum speed as soon as a call for heat is received. No blower calibration occurs.
3. **Electronic Air Cleaner**—The EAC-1 terminal does not operate in emergency heat mode.

4. **Humidifier**—The HUM terminal is energized IMMEDIATELY.
5. **Ignitor warm up**—The HSI is energized for a 17 sec warm-up period after prepurge period is completed.
6. **Ignition sequence**—After HSI warm-up period has completed, the gas valve is energized, permitting gas flow to burners where it is ignited. After 5 sec, the HSI is de-energized and a 2-sec flame-sensing period begins.

NOTE: Emergency heat mode only operates in high heat.

7. **Flame sensing**—When burner flame is sensed, control center holds gas valve open. If burner flame is not sensed, control center de-energizes gas valve and ignition sequence is repeated.

NOTE: Ignition sequence repeats 3 additional times before lock-out occurs. Lockout automatically resets after 3 hr, or can be manually reset by turning 115-v or 24-v power off (not at thermostat) for 3 sec minimum, then turning on again. Fault codes will not flash in emergency heat mode.

8. **Blower off delay**—When thermostat is satisfied, the R-W/W1 signal is terminated, de-energizing gas valve (stopping gas flow to burners) and HUM terminal is de-energized. In addition, blower stops immediately.
9. **Post purge**—Post purge does NOT occur. The inducer stops immediately.

V. COOLING MODE

When thermostat calls for cooling, the R-G and R-Y/Y2 circuits close.

1. **Cooling unit**—The cooling unit starts when thermostat R-Y signal is received.
2. **Blower on**—The control center starts blower immediately when it receives an R-Y/Y2 and R-G signal. The blower starts at approximately 400-500 RPM. After 20 sec, the blower is turned off for 1/10 of a sec where a coast down calibration is done to evaluate resistance of the conditioned air duct system. The microprocessor then determines blower RPM required to provide selected cooling airflow.

NOTE: In cooling mode, the microprocessor adjusts blower RPM to operate at 400 CFM per ton as selected on the A/C setup switches. See Air Conditioning Setup Switches section in Installation, Start-Up and Operating Instructions for details. There is also a chart on schematic in Appendix A.

NOTE: If Y/Y2 thermostat lead is not connected to furnace control center, blower motor operates in continuous fan speed and indoor coil freeze-up may occur.

3. **Electronic Air Cleaner**—The EAC-1 terminal is energized whenever blower operates.
4. **Cooling unit**—The cooling unit stops when thermostat R-Y signal is terminated.
5. **Blower off delay**—When thermostat is satisfied, the R-Y/Y2 and R-G signals are terminated, and blower remains operating for 90 sec.

VI. HEAT PUMP MODE

When furnace is operating in heat pump heating mode, R-Y/Y2 and R-G circuits are closed energizing heat pump, and blower operates at cooling speed. When heat pump defrost is required, R-W/W1 circuits close starting gas heat cycle, and blower adjusts to low-heat speed.

1. **Prepurge period**—The inducer motor is turned on and slowly comes up to speed. When low-pressure switch closes, inducer motor RPM is noted by microprocessor, and a 25 sec prepurge period begins. The RPM is used to evaluate vent system resistance. This evaluation is then used to determine required RPM necessary to operate inducer in low-heat mode.

NOTE: The heat cycle can start in either high or low heat. If a high-heat cycle is initiated, inducer continues increasing its speed after low-pressure switch closes. When high-pressure switch closes, inducer motor RPM is noted by microprocessor before the 25 sec prepurge period begins. The RPM is used to evaluate vent system resistance. This evaluation is used to determine required RPM necessary to operate inducer in high-heat mode.

2. **Humidifier**—The HUM terminal is energized whenever inducer prepurge period is completed.
3. **Ignitor warm up**—After prepurge period, HSI is energized for 17 sec.
4. **Ignition sequence**—After HSI warm-up period is completed, the gas valve is energized, permitting gas flow to the burners where it is ignited. After 5 sec, the HSI is de-energized and a 2-sec flame-sensing period begins.
5. **Flame sensing**—When burner flame is sensed, control center holds gas valve open.
If burner flame is not sensed, control center de-energizes gas valve and ignition sequence is repeated.
6. **Blower off period**—Ten sec after gas valve is energized, the blower stops for 25 sec to allow heat exchangers to warm up.
7. **Blower on delay**—After blower off period, blower starts.

NOTE: The blower starts at approximately 400-500 RPM. After 20 sec, the motor is turned off for 1/10 of a sec where a coast down calibration is done to evaluate resistance of the conditioned air duct system. The microprocessor then determines blower RPM required to provide proper airflow for heating mode.

8. **Electronic Air Cleaner**—The EAC-1 terminal is energized whenever blower operates.
9. **Inducer speed reduction**—If cycle starts in low heat, inducer speed reduces slightly after the flame sense. If cycle starts in high heat, inducer speed increases 15 sec after flame sense. The reduction in speed in low heat is to optimize combustion for maximum efficiency.
10. **Call for heat terminated**—When the call for heat is satisfied, the R-W/W1 signal is terminated, de-energizing gas valve (stopping gas flow to burners) and HUM terminal is de-energized.
 - a. **R-W/W1 signal terminated with R-Y/Y2 and R-G still present**—The blower changes its speed to cooling RPM.
 - b. **R-W/W1 with R-Y/Y2 and R-G signals terminated**—The blower continues to operate completing a normal blower off delay.
11. **Post purge**—The inducer continues operating for 15 sec after gas valve is de-energized.

VII. CONTINUOUS FAN MODE

1. **Operating with continuous fan only.**
 - a. **Call for continuous fan**—The thermostat closes R-G circuit.
 - b. **Blower on**—The blower starts immediately.

NOTE: The blower starts at approximately 400-500 RPM. After 20 sec, the motor is turned off for 1/10 of a sec where a coast down calibration is done to evaluate resistance of the conditioned air duct system. The microprocessor then determines blower RPM required to provide proper airflow for heating mode.

NOTE: The continuous fan speed is the same as low-heat speed unless it is field adjusted to another desired airflow. See Continuous Fan Setup Switches section in Installation, Start-Up, and Operating Instructions for details. There is also a chart on schematic diagram shown in Appendix A.

- c. **Electronic Air Cleaner**—The EAC-1 terminal is energized whenever blower operates, regardless of operating mode.
- 2. **Operating with continuous fan (R-G) and call for heat (R-W/W1) is received**—Same as heat pump mode except blower on delay is 10 sec less than the heat mode. After call for heat (R-W/W1) is terminated, the blower remains operating at low-heat speed for selected blower off delay before resuming continuous fan speed.
- 3. **Operating with continuous fan (R-G) and call for cooling (R-Y/Y2) is received**—See Cooling Mode section. After call for cooling (R-Y/Y2) is terminated, the blower remains operating at cooling speed for 90 sec before resuming continuous fan speed.

- 2. Inducer motor operates for 20 sec at low speed, operates 20 sec at high speed, then turns off.
- 3. Hot surface ignitor is energized for 15 sec, then de-energized.
- 4. Main blower motor operates for 20 sec at low speed, operates for 20 sec at high speed, then turns off.
- 5. After component operation test is completed, 1 or more fault codes (11, 22, 41, or 42) will flash. See service label on back of main furnace door or Fig. 1 for explanation of fault codes.

NOTE: To repeat component test, turn setup switch SW-6 to OFF and then back to ON.

After component test, perform the following:

- 1. Release blower panel access door switch and turn setup switch SW-6 to OFF position.
- 2. If applicable, replace blower access panel and check LED status by removing plug in blower access panel.
- 3. Reinstall main furnace door if all LEDs are off, indicating furnace is ready to operate when a signal from thermostat is received.

VIII. COMPONENT TEST

All components are functionally operated except gas valve with component test feature.

This feature helps diagnose a system problem in case of a component failure.

NOTE: Setup switch SW-1 MUST be in OFF position or Fault Code 22 (setup error) will occur.

NOTE: NO thermostat signal may be present at control center, and all blower time delay off periods must be completed.

To initiate component test feature, proceed with the following:

- 1. Leave 115-v power to furnace turned on.
- 2. Remove main furnace door.
- 3. Remove blower access panel.
- 4. Turn setup switch SW-6 to ON position.
- 5. Manually close blower access panel door switch.

IX. BYPASS HUMIDIFIER MODE

When setup switch SW-3 BPH is in ON position, RPM calculated for low heat is multiplied by 1.15 for all furnace model sizes. This compensates for increased return-air temperature caused by bypassed air supply.

X. DEHUMIDIFICATION MODE

If dehumidification input is energized with a 24-vac input, RPM calculated for cooling and continuous fan is multiplied by 0.85 for all furnace model sizes. This compensates for high humidity conditions during cooling operation.

XI. ZONE MODE

When setup switch SW-5 MZ is in ON position, blower motor control is the same as above except with the following exceptions:

- 1. While blower is operating in either low heat or continuous fan, the coast down calibration is performed once a minute to update blower RPM for zone damper position changes during a given cycle.

NOTE: Boards with date codes of 9506 or later will not perform a coast down calibration if blower pulse width to blower motor is greater than 60 percent. This prevents nuisance faults from occurring when a high continuous fan CFM has been selected.

- 2. While blower is operating in either high heat or cooling, blower pulse width to blower motor is frozen when blower RPM is within 10 percent of calculated blower RPM for 5 sec.

⚠	<p>WARNING: On some models, blower access panel door switch opens only 24-v power to control center. No component operation can occur. The 115-v power is still present at control center, transformer, inducer motor, and main blower motor. Caution must be taken when manually closing this switch for service purposes. Failure to follow this warning could result in personal injury or death.</p>
---	---

When items 1-5 have been completed, the following will occur:

- 1. The control center goes through a brief self test. This self test takes approximately 2 sec to complete. After door switch is closed, red (microprocessor) LED briefly comes on. Then green LED comes on for 1 sec, followed by 1 sec where both green and yellow LEDs are on. During this time, the microprocessor is checking itself.

START HERE—IF A PROBLEM EXISTS, THE SERVICE TECHNICIAN SHOULD ALWAYS BEGIN TROUBLESHOOTING HERE.

STEP		YES	NO	GO TO
1.	Remove main furnace door first. DO NOT REMOVE BLOWER ACCESS PANEL! Record status of LEDs 1-4. See Service Label/Fault Code Instructions (Fig. 1).	—	—	2
2.	Are any LEDs flashing?	5	3	—
3.	Are any LEDs on solid? (Solid means ON continuously.)	4	8	—
4.	Go to page number indicated in Index for LEDs 1, 2, 3, or 4 ON SOLID.	—	—	INDEX
5.	Is RED LED2 flashing?	6	7	—
6.	Go to page number indicated in Index for RED LED2 FLASHING.	—	—	INDEX
7.	Go to page number indicated in Index for subsection covering fault code being flashed.	—	—	INDEX
8.	Is power on? (DO NOT cycle power to unit).	10	9	—
9.	Turn power on.	—	—	20
10.	Remove blower access panel and depress door switch. Use a piece of tape to hold switch closed. Wait a few sec for self test before proceeding to next step.	—	—	11
11.	Does problem appear to be low cooling airflow?	12	13	—
12.	Go to page number indicated in Index for subsection covering NOT ENOUGH COOLING AIRFLOW.	—	—	INDEX
13.	Make sure thermostat is calling for heat.	—	—	14
14.	Make sure thermostat fan control is in AUTO position if equipped.	—	—	15
15.	Observe operation of furnace for 20 minutes or until fault occurs.	—	—	16
16.	Does a fault occur?	7	17	—
17.	Is temperature rise below range specified on rating plate when unit is running in high fire?	18	19	—
18.	Go to page number indicated in Index for subsection covering HIGH FIRE TEMPERATURE RISE TOO LOW (COLD BLOW).	—	—	INDEX
19.	Does furnace operate properly?	31	28	—
20.	Remove blower access panel and depress door switch. Use a piece of tape to hold switch closed. Wait a few sec for self test before proceeding to next step.	—	—	21
21.	Disconnect R thermostat lead, then wait until blower motor stops.	—	—	22
22.	Are any LEDs flashing?	24	23	—
23.	Are any LEDs on solid? (Solid means ON continuously.)	4	25	—
24.	Is RED LED2 flashing?	6	7	—
25.	Put setup switch SW-1 in ON position.	—	—	26
26.	Record fault codes listed in fault history. NOTE: Read fault codes until they repeat. The last fault code that occurred will flash first followed by the lowest number fault code. (EXAMPLE: 13, 13, 44)	—	—	27
27.	Are LEDs 3 and 4 flashing a Fault Code 11?	29	30	—
28.	Go to page number indicated in Index for subsection covering NO OPERATION WITH NO FLASHING FAULT CODE.	—	—	INDEX
29.	Go to page number indicated in Index for CLEANUP AND START-UP INSTRUCTIONS.	—	—	INDEX
30.	Go to page number indicated in Index for subsection covering first fault code flashed.	—	—	INDEX
31.	Disconnect the R thermostat lead, then wait until blower motor stops.	—	—	32
32.	Put setup switch SW-1 in ON position.	—	—	33
33.	Record fault codes listed in fault history. NOTE: Read fault codes until they repeat. The last fault code that occurred will flash first followed by the lowest number fault code. (EXAMPLE: 13, 13, 44)	—	—	34
34.	Are LEDs 3 and 4 flashing a Fault Code 11?	35	30	—
35.	Go to page number indicated in Index for the CLEANUP AND START-UP INSTRUCTIONS. If this problem persists on an intermittent basis, replace furnace control board. If problem still persists on an intermittent basis after replacing furnace control board, contact your distributor.	—	—	INDEX

SERVICE

LED CODE

RED LED1 ON
RED LED2 ON

STATUS

Furnace is operating in emergency heat.
The microprocessor has malfunctioned. To reset: Put setup switch "SW-1" in the "ON" position and jumper thermostat terminals "R", "W/W1", and "Y/Y2" simultaneously with the door switch pushed in and power to the unit "ON". Disconnect jumper and place setup switch in the "OFF" position. If LED2 reappears replace main control board.
Furnace is operating in high heat.
Furnace is operating in low heat.
Line voltage polarity is reversed.

YELLOW LED3 ON
GREEN LED4 ON
RED LED2 FLASHING

EACH OF THE FOLLOWING STATUS CODES IS A TWO DIGIT NUMBER WITH THE FIRST DIGIT DETERMINED BY NUMBER OF FLASHES OF THE YELLOW LED AND THE SECOND DIGIT DETERMINED BY NUMBER OF FLASHES OF THE GREEN LED.

- 11 **NO FAULT IN RECENT HISTORY DISPLAY** - Indicates no faults have occurred within last five cycles. To read recent fault history put setup switch "SW-1" in the "ON" position. To clear recent fault history, put setup switch "SW-1" in the "ON" position and jumper thermostat terminals "R", "W/W1", and "Y/Y2" simultaneously until an "11" is flashed.
- 12 **BLOWER CALIBRATION LOCKOUT** - Indicates RPM calculated for low heat was less than 250 RPM or greater than 1300 RPM on two successive attempts. Auto reset after three hours. Reset power and refer to fault #44 section.
- 13 **LIMIT SWITCH LOCKOUT** - Indicates the occurrence of 10 successive limit trips during high heat or three successive limit trips during low heat. Auto reset after three hours.
Check for:
- Improper or misaligned limit and/or limit shield.
- Improper high or low heat gas input adjustment.
- Stuck high heat solenoid in gas valve.
- 14 **IGNITION LOCKOUT** - Control will auto-reset after three hours. Refer to #34.
- 21 **INVALID MODEL SELECTION** - Indicates model plug is missing or incorrect. See wiring diagram for correct connector jumper location.
- 22 **SETUP ERROR** - Indicates setup switch "SW-1" or SW-6" is positioned improperly. The following combinations will cause the fault:
- Thermostat call with "SW-1" "ON".
- Thermostat call with "SW-6" "ON".
- "SW-1" and "SW-6" both "ON" together.
- 23 **INVALID BLOWER AIRFLOW SELECTION** - Indicates improper "A/C" or "CF" switch setting. The 042 and 14 units can deliver 1-1/2 to 3-1/2 tons A/C and 600 to 1400 CFM for continuous fan. The 060 and 20 unit will default to closest allowable airflow.
- 24 **SECONDARY VOLTAGE FUSE IS OPEN** - Indicates the fuse is open and there is a short circuit in the low voltage wiring.
- 31 **HIGH PRESSURE SWITCH FAULT** - Indicates high pressure switch is closed at call, or in low heat, or fails to close after call, or opens in high heat.
Check for:
- Plugged condensate drain.
- Water in vent piping, possibly sagging pipe.
- Improper pressure switch wiring or pressure switch tubing connections.
- Failed or "Out-of-Calibration" pressure switches.
- 32 **LOW PRESSURE SWITCH FAULT** - Indicates low pressure switch is closed at call, or fails to close after call, or opens during operation.
Check for:
- Plugged condensate drain.
- Water in vent piping, possibly sagging pipe.
- Improper pressure switch wiring or pressure switch tubing connections.
- Failed or "Out-of-Calibration" pressure switches.
- 33 **LIMIT SWITCH FAULT** - Indicates the limit, rollout switch or auxiliary limit switch is open or the unit is operating in high heat only mode due to two successive low heat limit trips.
Check for:
- Improper or misaligned limit and/or limit shield.
- Improper low heat gas input adjustment.
- Stuck high heat solenoid in gas valve.

34 **IGNITION PROVING FAULT** - Control will try three more times before a lockout #14 occurs.

Check for:

- Gas valve turned "OFF".
- Oxide buildup on flame sensor (clean with fine sandpaper.)
- Main shutoff valve turned "OFF".
- Green wire **MUST** be connected to furnace sheet metal.
- Proper flame sense microamps (.5 microamps D.C. minimum)
- Inadequate flame carryover or rough ignition.
- Low inlet gas pressure

41 **BLOWER OUTSIDE VALID SPEED RANGE** - Indicates the blower is not operating at the calculated RPM. If this fault occurs in conjunction with fault #44 check wiring to motor otherwise refer to the trouble-shooting guide.

42 **INDUCER OUTSIDE VALID SPEED RANGE** - Indicates the inducer is not operating at the calculated RPM, or has not started within 10 seconds after a call for heat. Check wiring to motor otherwise refer to the trouble-shooting guide.

43 **PRESSURE SWITCH CALIBRATION FAULT** - Indicates the low and high pressure switch "make" points during high heat purge are not within the calibration range.

Check for:

- Plugged condensate drain.
- Water in vent piping, possibly sagging pipe.
- Improper pressure switch wiring or pressure switch tubing connections.
- Failed or "Out of Calibration" pressure switches.

44 **BLOWER CALIBRATION FAULT** - Indicates the calculated blower speed is below 250 or above 1300 RPM. Unit will default to low or high heat mode if possible. If this fault occurs in conjunction with fault #41 check wiring to motor otherwise refer to the trouble-shooting guide. If this fault occurs by itself check for undersized ductwork, or excessive static caused by a dirty filter, or closed registers.

STATUS CODE EXAMPLE

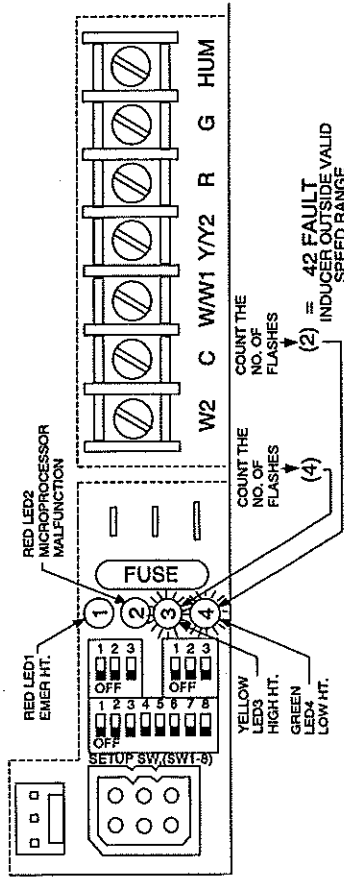

COMPONENT TEST

To initiate the component test sequence, shut "OFF" the room thermostat or disconnect the "R" thermostat lead. Put setup switch "SW-6" in the "ON" position to start the component test sequence. Once initiated the main board will turn "ON" the inducer motor-low speed, inducer motor-high speed, hot surface ignitor, blower motor-low speed, and blower motor-high speed for 15-20 seconds each. When component test is completed one or more of the following codes will flash.

CODE

- 11 Indicates inducer and blower motor tested OK. Visual check of hot surface ignitor required.
- 22 **SETUP ERROR** - Same as code 22 above.
- 41 **BLOWER OUTSIDE VALID SPEED RANGE** - Indicates blower motor failed test. Check blower, wiring, and control center.
- 42 **INDUCER OUTSIDE VALID SPEED RANGE** - Indicates inducer motor failed test. Check inducer, wiring and control center.

To repeat component test turn setup switch "SW-6" "OFF" and then back "ON". After component test is completed put setup switch "SW-6" in the "OFF" position and reconnect the "R" thermostat lead.

920624-101 REV. F

A93305

Fig. 1—Service Label/Fault Code Instructions

IMPROPER OPERATION WITH NO FLASHING FAULT CODE—GENERALLY, THIS INDICATES THERE IS NO POWER TO FURNACE CONTROL BOARD.

STEP		YES	NO	GO TO
1.	Make sure power is on.	—	—	2
2.	Remove blower access panel and depress door switch. Use a piece of tape to hold switch closed. Wait a few sec for self test before proceeding to next step.	—	—	3
3.	Make sure thermostat is calling for heat.	—	—	4
4.	Make sure thermostat fan control is in AUTO position if equipped.	—	—	5
5.	Check fuses, breakers, or manual disconnects to be sure they are correctly set.	—	—	6
6.	Does 120-v wiring match unit wiring schematic?	9	7	—
7.	Fix problem.	—	—	8
8.	Go to page number indicated in Index for CLEANUP AND START-UP INSTRUCTIONS.	—	—	INDEX
9.	Do you have 120 vac at primary leads P1 and P2 on furnace control board?	14	10	—
10.	Do you have 120 vac to furnace control board?	11	12	—
11.	Check all 120-vac connections at furnace control board. If necessary, replace furnace control board.	—	—	8
12.	Turn power off.	—	—	13
13.	Check continuity of power supply leads and door switch if wired with 120 vac.	—	—	7
14.	Do you have 24v between SEC-1 and SEC-2 on furnace control board?	19	15	—
15.	Turn power off.	—	—	16
16.	Do you have continuity across door switch?	17	18	—
17.	Replace transformer. If transformer fails again, replace transformer and furnace control board.	—	—	8
18.	Replace door switch.	—	—	8
19.	Do you have 24v between R and Com on furnace control board?	21	20	—
20.	Replace furnace control board.	—	—	8
21.	Do you have 24v between W/W1 and Com on furnace control board?	24	22	—
22.	Check to see that thermostat is calling for heat.	—	—	23
23.	You have a defective thermostat or a break in the wiring between thermostat and furnace.	—	—	7
24.	Does furnace respond to the call for heat?	27	25	—
25.	Turn power off.	—	—	26
26.	Press down on microprocessor chip and make sure it is properly seated to furnace control board. If it is, replace furnace control board.	—	—	7
27.	Does furnace keep repeating the following cycle? Inducer motor MTR1 runs, inducer motor MTR1 stops, furnace control board goes through a self-test sequence, blower motor runs for 1 minute, and then cycle repeats.	28	34	—
28.	Disconnect BROWN wire to gas valve GV.	—	—	29
29.	Does furnace still alternately cycle inducer motor, go through a self test, and then run blower motor as described in Step 27?	30	37	—
30.	Disconnect humidifier lead from HUM terminal on furnace control board.	—	—	31
31.	Does furnace still alternately cycle inducer motor, go through a self test, and then run blower motor as described in Step 27?	33	32	—
32.	There is a direct short in wiring to humidifier solenoid coil, or short is inside humidifier solenoid coil.	—	—	7
33.	There is a direct short in either the pressure switch circuits, gas valve GV, or wiring to gas valve GV. If hot surface ignitor comes on during the cycle, short is in gas valve or wiring to gas valve.	—	—	7
34.	Does furnace ever abruptly shut down with no fault code, no inducer post purge, no blower off delay, and then restart heating cycle?	35	38	—
35.	Disconnect BROWN wire to gas valve GV.	—	—	36
36.	Does furnace still abruptly shut down with no fault code, no inducer post purge, no blower off delay, and then restart heating cycle?	39	37	—
37.	Replace gas valve.	—	—	8
38.	Go to page number indicated in Index for CLEANUP AND START-UP INSTRUCTIONS. If problem persists on an intermittent basis, replace furnace control board. If problem still persists after replacing furnace control board, contact your distributor.	—	—	INDEX
39.	Disconnect humidifier lead from HUM terminal on furnace control board.	—	—	40
40.	Does furnace still abruptly shut down with no fault code, no inducer post purge, no blower off delay, and then restart heating cycle?	33	32	—

NOT ENOUGH COOLING AIRFLOW—GENERALLY, THIS INDICATES THE Y/Y2 THERMOSTAT LEAD IS NOT PROPERLY CONNECTED.

STEP		YES	NO	GO TO
1	Remove blower access panel and depress door switch. Use a piece of tape to hold switch closed. Wait a few sec for self test before proceeding to next step.	—	—	2
2.	Make sure thermostat is calling for cooling. If thermostat lead G is not connected, jumper across thermostat terminals R and G.	—	—	3
3.	Make sure thermostat fan control is in AUTO position if equipped.	—	—	4
4.	Do you have 24v across Y/Y2 and Com on furnace control board?	8	5	—
5.	You have a defective thermostat, or a break in wiring between thermostat and furnace, or the Y/Y2 thermostat terminal is not wired to thermostat.	—	—	6
6.	Fix problem.	—	—	7
7.	Go to page number indicated in Index for CLEANUP AND START-UP INSTRUCTIONS.	—	—	INDEX
8.	Are air conditioning select switches A/C set to proper tonnage as required by condensing unit? (See Table 1.)	10	9	—
9.	Set air conditioning select switches A/C for proper tonnage as required by condensing unit. (See Table 1.)	—	—	7
10.	Disconnect the G thermostat lead or jumper if used.	—	—	11
11.	Does blower motor turn off in 90 sec when G thermostat lead is disconnected?	12	13	—
12.	Replace furnace control board.	—	—	7
13.	Observe operation of furnace in cooling mode for 8 minutes.	—	—	14
14.	Does furnace operate properly in cooling mode?	15	16	—
15.	Make sure outdoor unit is properly charged. If it is, go to page number indicated in Index for CLEANUP AND START-UP INSTRUCTIONS. If problem persists on an intermittent basis, replace furnace control board. If problem still persists after replacing furnace control board, contact your distributor.	—	—	INDEX
16.	Does furnace abruptly go through a self-test sequence as blower comes up to speed?	17	24	—
17.	Do you have less than 17 vac between R and Com on furnace control board?	18	24	—
18.	Do you have less than 90 vac between P1 and P2 on furnace control board?	19	20	—
19.	Make sure the wire gage between main fuse box and furnace complies with wire size specification in Installation, Start-Up, and Operating Instructions.	—	—	6
	Disconnect the R thermostat lead.	—	—	21
20.	Do you have less than 17 vac between R and Com on furnace control board?	22	23	—
22.	Replace transformer.	—	—	7
23.	Check the thermostat wire gage between furnace and thermostat, and furnace and outdoor unit. It is recommended that AWG No. 18 color-coded copper thermostat wire be used for lengths up to 100 ft. For wire lengths over 100 ft, use AWG No. 16 wire.	—	—	6
24.	Press down on microprocessor chip and make sure it is properly seated to furnace control board. If it is, replace furnace control board.	—	—	6

TABLE 1—AIR CONDITIONING (A/C) AIRFLOW SETUP SWITCH POSITION

AIR CONDITIONER (TONS)	AIRFLOW (CFM)	A/C SWITCH POSITION			ALLOWABLE FURNACE MODEL SETUP			
		A/C-1	A/C-2	A/C-3	042040	042060	042080	060100
Default	1200 or 2000	OFF	OFF	OFF	3 Tons 1200 CFM	3 Tons 1200 CFM	3 Tons 1200 CFM	5 Tons 2000 CFM
1-1/2	600	ON	OFF	OFF	X	X	X	—
2	800	OFF	ON	OFF	X	X	X	X
2-1/2	1000	ON	ON	OFF	X	X	X	X
3	1200	OFF	OFF	ON	X	X	X	X
3-1/2	1400	ON	OFF	ON	X	X	X	X
4	1600	OFF	ON	ON	—	—	—	X
5	2000	ON	ON	ON	—	—	—	X

(—) Indicates allowable selection.

HIGH-FIRE TEMPERATURE TOO LOW—GENERALLY, THIS INDICATES THE HIGH/LOW SOLENOID IN GAS VALVE GV HAS FAILED OR FURNACE IS EXTREMELY UNDERFIRED.

STEP		YES	NO	GO TO
1.	Turn power off and remove blower access panel. Make sure thermostat is NOT calling for heat.	—	—	2
2.	Depress door switch. Use a piece of tape to hold switch closed. Wait a few sec for self test before proceeding to next step.	—	—	3
3.	Set thermostat to call for heat or jumper R and W/W1 thermostat terminals.	—	—	4
4.	When GREEN LED4 is ON solid, clock low-fire gas rate. You have 16 minutes on this first call for heat. On propane installations, check manifold pressure.	—	—	5
5.	When YELLOW LED3 is ON solid, clock high-fire gas rate. On propane installations, check manifold pressure.	—	—	6
6.	Is high-fire rate approximately same as low-fire rate?	7	11	—
7.	Do you have 24 vac across gas valve terminal HI and Com on furnace control board during high fire?	10	8	—
8.	You have an open wire or bad terminal on BROWN wire from furnace control board to gas valve GV. Repair it or replace the harness.	—	—	9
9.	Go to page number indicated in Index for CLEANUP AND START-UP INSTRUCTIONS.	—	—	INDEX
10.	Replace gas valve.	—	—	9
11.	Is high-fire rate within 2% of that specified on rating plate?	13	12	—
12.	Ensure gas inlet pressure and burner orifices are correct, then adjust gas valve to proper rate. If it cannot be adjusted to proper rate, replace gas valve.	—	—	9
13.	Check outdoor condensing unit for operation during heating cycle.	—	—	14
14.	Check temperature rise with blower door in place. Temperature rise should be mid-range or slightly higher than midpoint of range stated on furnace rating plate. If return temperature is below 60°F, condensation may form on heat exchangers. If left uncorrected, failure will result.	—	—	15
15.	Check return-air ducts in unheated spaces for leaks.	—	—	9

LEDS 1, 2, 3, OR 4 ON SOLID (SOLID MEANS ON CONTINUOUSLY.)

- RED LED1 ON SOLID indicates furnace is operating in emergency heat.
- D LED2 ON SOLID indicates microprocessor has malfunctioned or secondary voltage to furnace control board is low.
- YELLOW LED3 ON SOLID indicates furnace is operating in high fire.
- GREEN LED4 ON SOLID indicates furnace is operating in low fire.

STEP		YES	NO	GO TO
1.	Turn power off and remove blower access panel.	—	—	2
2.	Turn power on and depress door switch. Use a piece of tape to hold switch closed.	—	—	3
3.	Jumper R and W/W1 thermostat terminals on furnace control board.	—	—	4
4.	Is RED LED1 ON?	5	9	—
5.	Is setup switch SW-4 labeled EMER. HEAT in ON position?	6	7	—
6.	Put setup switch SW-4 labeled EMER. HEAT in OFF position.	—	—	8
7.	Replace furnace control board.	—	—	8
8.	Go to page number indicated in Index for CLEANUP AND START-UP INSTRUCTIONS.	—	—	INDEX
9.	Disconnect jumper wire across R and W/W1 thermostat terminals.	—	—	10
10.	Is RED LED2 ON?	11	32	—
11.	Do you have less than 17 vac between R and Com on furnace control board?	12	19	—
12.	Do you have less than 90 vac between P1 and P2 on furnace control board?	13	15	—
13.	Make sure wire gage between main fuse box and furnace complies with wire size specification in Installation, Start-Up, and Operating Instructions.	—	—	14
14.	Fix problem.	—	—	8
15.	Disconnect R thermostat lead.	—	—	16
16.	Is RED LED2 ON?	17	18	—
17.	Replace transformer.	—	—	8
18.	Check thermostat wire gage between furnace and thermostat, and furnace and outdoor unit. It is recommended that AWG No. 18 color-coded copper thermostat wire be used for lengths up to 100 ft. For wire lengths over 100 ft, use AWG No. 16 wire.	—	—	14
19.	Disconnect all thermostat leads from furnace control board.	—	—	20
20.	Put setup switch SW-1 in ON position and jumper R, W/W1, and Y/Y2 thermostat terminals.	—	—	21
21.	Does RED LED2 turn OFF?	22	7	—
22.	Put setup switch SW-1 back in OFF position.	—	—	23

STEP		YES	NO	GO TO
23.	Turn power off and reconnect thermostat leads to furnace control board.	—	—	24
24.	Turn power on.	—	—	25
25.	Does RED LED2 turn back ON?	26	36	—
	Disconnect all thermostat leads from thermostat control board.	—	—	27
27.	Put setup switch SW-1 in ON position and jumper R, W/W1, and Y/Y2 thermostat terminals simultaneously until RED LED2 turns OFF.	—	—	28
28.	Put setup switch SW-1 back in OFF position.	—	—	29
29.	Jumper R and W/W1 thermostat terminals.	—	—	30
30.	Does RED LED2 turn back ON?	7	31	—
31.	Install isolation relays in the W/W1 and Y/Y2 circuits per Fig. 2 in Appendix B or replace thermostat.	—	—	8
32.	Was RED LED2 ON before you started Step 1?	34	33	—
33.	Solid YELLOW LED3 indicates furnace is in high fire and solid GREEN LED4 indicates furnace is in low fire.	—	—	8
34.	Check outdoor unit contactor. Failure to pull in can cause excessive current draw on low-voltage circuit. This can be intermittent and may require extended operation to repeat problem. Isolating outdoor unit may solve problem. (See Fig. 3 in Appendix B.)	—	—	35
35.	Check thermostat wire gage between furnace and outdoor unit. It is recommended that AWG No. 18 color-coded copper thermostat wire be used for lengths up to 100 ft. For wire lengths over 100 ft, use AWG No. 16 wire.	—	—	14
36.	Observe operation of furnace through a 20 minute heat cycle. Try to pinpoint where in cycle RED LED2 turns ON.	—	—	37
37.	Go to step indicated below if RED LED2 turns ON when 1 of the following events occur:	—	—	—
	• When gas valve is energized.	—	—	38
	• When HSI is energized.	—	—	39
	• When high-pressure switch HPS makes during transition from low to high fire.	—	—	38
38.	Replace gas valve.	—	—	8
39.	Isolate humidifier with a separate 24-vac supply or replace humidifier solenoid coil.	—	—	14
	Observe operation of furnace through a 4 minute cooling cycle. Does RED LED2 turn ON?	41	47	—
41.	Disconnect all thermostat leads from furnace control board.	—	—	42
42.	Put setup switch SW-1 in ON position and jumper R, W/W1, and Y/Y2 thermostat terminals simultaneously until RED LED2 turns OFF.	—	—	43
43.	Put setup switch SW-1 back in OFF position.	—	—	44
44.	Reconnect only outdoor unit to Y/Y2 and Com terminals on furnace control board.	—	—	45
45.	Jumper R and Y/Y2 thermostat terminals.	—	—	46
46.	Does RED LED2 turn back ON?	34	31	—
47.	Go to page number indicated in Index for CLEANUP AND START-UP INSTRUCTIONS. If problem persists on an intermittent basis, replace furnace control board. If problem still persists on an intermittent basis after replacing furnace control board, contact your distributor.	—	—	INDEX

ED LED2 FLASHING—INDICATES LINE VOLTAGE POLARITY IS REVERSED.

STEP		YES	NO	GO TO
1.	Turn power off, remove blower access panel, and disconnect all thermostat leads from furnace control board.	—	—	2
2.	Turn power on and depress door switch. Use a piece of tape to hold switch closed.	—	—	3
3.	Is RED LED2 flashing?	6	4	—
4.	Replace furnace control board, date code 9405 or later.	—	—	5
5.	Go to page number indicated in Index for CLEANUP AND START-UP INSTRUCTIONS.	—	—	INDEX
6.	Do you have 120 vac across L2 and chassis ground?	7	8	—
7.	Line voltage polarity is reversed. Fix problem.	—	—	5
8.	Replace furnace control board.	—	—	5

Fault Code 11

NO FAULT IN RECENT HISTORY DISPLAY—THIS INDICATES 1 OF THE FOLLOWING:

- No faults have occurred in the last 5 previous cycles and setup switch SW-1 is in ON position.
- The fault history can be cleared by jumpering R, W/W1, and Y/Y2 thermostat leads simultaneously while setup switch SW-1 is in ON position.
- Component test was successfully completed and setup switch SW-6 is in ON position.

STEP		YES	NO	GO TO
1.	Remove blower access panel and depress door switch. Use a piece of tape to hold switch closed.	—	—	2
2.	Is setup switch SW-1 in ON position?	3	5	—
3.	Put setup switch SW-1 in OFF position.	—	—	4
4.	Go to page number indicated in Index for CLEANUP AND START-UP INSTRUCTIONS.	—	—	INDEX
5.	Is setup switch SW-6 in ON position.	6	7	—
6.	Put setup switch SW-6 in OFF position.	—	—	4
7.	Jiggle setup switches SW-1 and SW-6 back and forth. If Fault Code 11 continues to flash, replace furnace control board.	—	—	4

Fault Code 12

BLOWER CALIBRATION LOCKOUT—THIS FAULT INDICATES THAT BLOWER MOTOR SPEED CALCULATED FOR LOW HEAT IS EITHER LESS THAN 250 RPM OR GREATER THAN 1300 RPM ON 2 SUCCESSIVE ATTEMPTS AT CALIBRATION. CONTROL WILL AUTO-RESET IN 3 HOURS.

STEP		YES	NO	GO TO
1.	Turn power off, wait 30 sec, and then restore power. Reset thermostat. Observe operation of furnace through 1 heating cycle. NOTE: Blower access panel must be in place.	—	—	2
2.	Does only Fault Code 44 flash?	40	6	—
3.	The problem is excessive restriction in the air delivery system. Check filters and ductwork. Use Appendix E to evaluate.	—	—	4
4.	Fix problem.	—	—	5
5.	Go to page number indicated in Index for CLEANUP AND START-UP INSTRUCTIONS.	—	—	INDEX
6.	Does Fault Code 44 flash twice followed by Fault Code 41?	9	7	—
7.	Does a different fault occur?	8	39	—
8.	Go to page number indicated in Index for fault code flashed.	—	—	INDEX
9.	Turn power off and remove blower access panel.	—	—	10
10.	Are all pins and wire leads intact on connectors between furnace control board and blower motor.	11	4	—
11.	Depress door switch. Use a piece of tape to hold switch closed. Wait a few sec for self test before proceeding to next step.	—	—	12
12.	Disconnect all thermostat leads from furnace control board and jumper R and W/W1 thermostat terminals.	—	—	13
13.	Does blower motor turn on and come up to speed (400-500 RPM) before fault code flashes?	14	20	—
14.	Disconnect jumper wire across R and W/W1 thermostat terminals, turn power off, and then restore power. Wait a few sec for self test before proceeding to next step.	—	—	15
15.	Check RPM feedback line. To do this, connect a DC voltmeter across terminals PL3-2 ORANGE (+) and PL3-3 VIOLET (-), then put setup switch SW-6 for COMPONENT TEST in ON position. Does voltage across ORANGE and VIOLET wires change between states as shown below? <ul style="list-style-type: none"> • State 1—OFF (12.0 — 12.5 vdc) • State 2—LOW (10.7 — 11.7 vdc) • State 3—HIGH (9.7 — 10.7 vdc) 	16	17	—
16.	Replace furnace control board.	—	—	5

STEP		YES	NO	GO TO
17.	Connect a DC voltmeter across ORANGE (+) and VIOLET (-) wires at connector PL13, then repeat the COMPONENT TEST by turning setup switch SW-6 OFF and then back ON. Do you see approximately the same DC voltages across ORANGE and VIOLET wires that you saw in Step 15?	18	19	—
	Replace blower motor.	—	—	5
19.	You have an open wire or bad terminal on either the ORANGE or VIOLET wire between connectors PL13 and PL3. Repair it or replace blower harness(es).	—	—	5
20.	Remove tape from door switch and turn power off at main disconnect.	—	—	21
21.	Does blower wheel rub against blower housing?	4	22	—
22.	Does blower wheel turn freely?	23	24	—
23.	Is blower wheel firmly mounted on motor shaft?	25	4	—
24.	Replace blower motor. Inspect electronics portion of failed motor for water damage. If present, find source of water and fix. Check A-coil and/or humidifier.	—	—	5
25.	Disconnect jumper wire across R and W/W1 thermostat terminals.	—	—	26
26.	Turn power back on. Depress door switch. Use a piece of tape to hold switch closed. Wait a few sec for self test before proceeding to next step.	—	—	27
27.	Do you have 120v between B1 and B2 on furnace control board?	28	4	—
28.	Do you have 120v between BLACK and WHITE power leads at blower motor MTR2?	30	29	—
29.	You have an open wire or bad terminal on either the BLACK or WHITE wire between furnace control board and blower motor MTR2.	—	—	5
30.	Check blower ON/OFF line. To do this, connect a DC voltmeter across terminals PL3-1 RED (+) and PL3-5 BLUE (-), then put setup switch SW-6 for COMPONENT TEST in ON position. Does voltage across RED and BLUE wires change between states as shown below? <ul style="list-style-type: none"> • State 1—OFF (-0.1 — 0.1 vdc) • State 2—ON (9.0 — 10.0 vdc) 	32	31	—
31.	Disconnect PL3 from furnace control board and connect a DC voltmeter across terminals PL3-1 (+) and PL3-5 (-) on furnace control board, then repeat COMPONENT TEST by turning setup switch SW-6 OFF and then back ON. Does voltage across PL3-1 and PL3-5 change between states as shown below? <ul style="list-style-type: none"> • State 1—OFF (-0.1 — 0.1 vdc) • State 2—ON (11.0 — 12.0 vdc) 	18	16	—
	Connect a DC voltmeter across RED (+) and BLUE (-) wires at connector PL13 then repeat COMPONENT TEST by turning setup switch SW-6 OFF and then back ON. Do you see approximately the same DC voltages across RED and BLUE wires that you saw in Step 30?	34	33	—
33.	You have an open wire or bad terminal on either the RED or BLUE wire between connectors PL13 and PL3. Repair it or replace blower harness(es).	—	—	5
34.	Put setup switch SW-6 for COMPONENT TEST in OFF position.	—	—	35
35.	Check blower PW line. To do this, connect a DC voltmeter across terminals PL3-1 RED (+) and PL3-4 YELLOW (-), then put setup switch SW-6 for COMPONENT TEST in ON position. Does voltage across the RED and YELLOW wires change between states as shown below? <ul style="list-style-type: none"> • State 1—OFF (-0.1 — 0.1 vdc) • State 2—LOW (2.5 — 3.0 vdc) • State 3—HIGH (7.0 — 7.5 vdc) 	37	36	—
36.	Disconnect PL3 from furnace control board and connect a DC voltmeter across terminals PL3-1 (+) and PL3-4 (-) on furnace control board then repeat COMPONENT TEST by turning setup switch SW-6 OFF and then back ON. Does voltage across PL3-1 and PL3-4 change as shown below? <ul style="list-style-type: none"> • State 1—OFF (-0.1 — 0.1 vdc) • State 2—LOW (3.0 — 4.0 vdc) • State 3—HIGH (9.0 — 10.0 vdc) 	18	16	—
37.	Connect a DC voltmeter across RED (+) and YELLOW (-) wires at connector PL13 then repeat COMPONENT TEST by turning setup switch SW-6 OFF and then back ON. Do you see approximately the same DC voltages across RED and YELLOW wires that you saw in Step 35?	18	38	—
38.	You have an open wire or bad terminal on either the RED or YELLOW wire between connectors PL13 and PL3. Repair it or replace blower harness(es).	—	—	5
39.	Go to page number indicated in Index for CLEANUP AND START-UP INSTRUCTIONS. If problem persists on an intermittent basis, replace blower motor. If problem still persists on an intermittent basis after replacing blower motor, contact your distributor.	—	—	INDEX
40.	Turn power off and remove blower access panel. Depress door switch. Use a piece of tape to hold switch closed. Wait a few sec for self test before proceeding to next step.	—	—	41

STEP		YES	NO	GO TO
41.	Disconnect all thermostat leads from furnace control board. If blower motor is running, wait until it stops.	—	—	42
2.	Jumper R and G thermostat terminals. Observe operation of furnace for next 30 sec.	—	—	43
43.	Approximately 20 sec after energizing G thermostat terminal, does blower motor pause briefly (less than 1/2 sec)? NOTE: You can verify this pause using a clamp-on ammeter on BLACK power lead to blower motor MTR2.	3	18	—

Fault Code 13

LIMIT SWITCH LOCKOUT—THIS FAULT INDICATES THE LIMIT SWITCH HAS TRIPPED 10 TIMES IN A ROW IN HIGH FIRE OR 3 TIMES IN A ROW IN LOW FIRE DURING A CALL FOR HEAT. CONTROL WILL AUTO-RESET IN 3 HR.

NOTE: After 2 low-fire limit trips, the control is locked into high-heat mode; however, a third low-heat cycle can be forced due to excessive restriction in air delivery system.

NOTE: Boards with date codes of 9506 or later will lock into high-heat mode after 2 low-fire limit trips and CANNOT be forced into a third low-heat cycle. Therefore, units with these boards can only lock out if the limit switch trips 10 times in a row in high fire during a call for heat.

STEP		YES	NO	GO TO
1.	Turn power off and remove blower access panel. Disconnect all thermostat leads from furnace control board.	—	—	2
2.	Depress door switch. Use a piece of tape to hold switch closed.	—	—	3
3.	Put setup switch SW-1 in ON position.	—	—	4
4.	Is a Fault Code 44 present in the fault history. NOTE: Read fault codes until they repeat. The last fault code that occurred will flash first followed by the lowest number fault code. (EXAMPLE: 13, 13, 44)	46	5	—
5.	Put setup switch SW-1 in OFF position.	—	—	42
6.	Does furnace have proper limit switch, limit shield, blower baffle (if used), and rear air baffle (if used)? If so are limit switch, limit shield, and heat exchangers properly aligned?	10	48	—
7.	Replace limit switch.	—	—	9
8.	Replace furnace control board.	—	—	9
9.	Go to page number indicated in Index for CLEANUP AND START-UP INSTRUCTIONS.	—	—	INDEX
10.	Put setup switch SW-2 in ON position.	—	—	11
11.	Jumper R and W/W1 thermostat terminals on furnace control board.	—	—	12
12.	Is furnace considerably overfired (10% or more)? Clock input rate. Do not use manifold pressure method unless using propane.	13	14	—
13.	Ensure gas inlet pressure and burner orifices (natural or propane) are correct. Then adjust gas valve to proper rate per Installation, Start-Up, and Operating Instructions. If it cannot be adjusted to proper rate, replace gas valve.	—	—	9
14.	Is the personality connector PL5 properly wired per furnace model sizing chart in upper left-hand corner of wiring schematic?	50	15	—
15.	Replace or rewire personality connector.	—	—	9
16.	Does the installation have a bypass humidifier?	17	30	—
17.	Is setup switch SW-3 in ON position?	19	18	—
18.	Put setup switch SW-3 in ON position.	—	—	9
19.	Cycle furnace with blower access panel in place and record temperature rise across furnace 6 minutes after main burner ignition.	—	—	20
20.	Disconnect jumper wire across R and W/W1 thermostat terminals and wait until blower stops.	—	—	21
21.	Remove blower access panel and put setup switch SW-3 in OFF position.	—	—	22
22.	Cycle furnace with blower access panel in place and record temperature rise across furnace 6 minutes after main burner ignition.	—	—	23
23.	Is the temperature rise in Step 22 more than 10°F higher than the temperature rise in Step 19?	24	8	—
24.	Disconnect jumper wire across R and W/W1 thermostat terminals and wait until blower stops.	—	—	25
25.	Remove blower access panel and put setup switch SW-3 in ON position.	—	—	26
26.	Cycle furnace with blower access panel in place and record the temperature rise across return air duct before and after the bypass.	—	—	27

STEP		YES	NO	GO TO
27.	Is temperature rise from bypass greater than 15°F?	28	29	—
28.	The bypass is oversized. Adjust damper or replace with properly sized bypass.	—	—	9
	Disconnect jumper wire across R and W/W1 thermostat terminals and wait until blower stops.	—	—	30
29.	Does the installation have modulating zone dampers?	31	51	—
31.	Is setup switch SW-5 in ON position?	33	32	—
32.	Put setup switch SW-5 in ON position?	—	—	9
33.	Jumper R and W/W1 thermostat terminals on furnace control board.	—	—	34
34.	Does blower recalibrate every minute? Check by monitoring DC voltage across terminals PL3-1 RED (+) and PL3-5 BLUE (-). If DC voltage momentarily goes down to 0 vdc approximately every 60 sec after first blower calibration, then blower is recalibrating properly.	35	8	—
35.	Disable modulating zone damper system with all dampers in open position except bypass damper. If the installation is equipped with a bypass damper, it should be in the closed position.	—	—	36
36.	Put setup switch SW-2 in OFF position. Disconnect jumper wire across R and W/W1 thermostat terminals and reset the power. Reconnect jumper wire across R and W/W1 thermostat terminals and monitor manifold gas pressure while observing furnace operation for 10 minutes. NOTE: Blower access panel must be in place.	—	—	37
37.	Does a Fault Code 33 flash?	39	38	—
38.	The problem is caused by the modulating zone damper system. Install a 2-stage thermostat and let the zone system modulate gas flow. If you still have a problem, check the zone manufacturer's Installation and Troubleshooting Guide for corrective action.	—	—	9
39.	While monitoring manifold pressure in Step 36, did it drop to low-fire manifold pressure during low-fire operation?	49	40	—
40.	Replace gas valve.	—	—	9
41.	Replace blower motor and belly band. NOTE: Torque belly band screw to 80 in. lb (6.7 ft lb). WARNING: DO NOT OVERTIGHTEN!	—	—	9
42.	Jumper R, W/W1, and W2 thermostat terminals on furnace control board.	—	—	43
43.	Is furnace considerably overfired (10% or more)? Clock input rate. Do not use manifold pressure method unless using propane.	44	45	—
44.	Ensure gas inlet pressure and burner orifices (natural or propane) are correct. Then adjust gas valve to proper rate per the Installation, Start-Up, and Operating Instructions. If it cannot be adjusted to proper rate, replace gas valve.	—	—	9
45.	Disconnect jumper wire across R, W/W1, and W2 thermostat terminals and wait until blower stops.	—	—	6
46.	Excessive restriction of airflow during locked in high-fire mode caused lockout.	—	—	47
47.	Relieve restriction. Check all dampers, filters, and return-air grilles for blockage. Put setup switch SW-1 in OFF position.	—	—	42
48.	Fix problem.	—	—	9
49.	Is temperature rise within $\pm 10^\circ\text{F}$ of midpoint of rise range?	51	41	—
50.	Is temperature rise within $\pm 10^\circ\text{F}$ of midpoint of rise range?	51	16	—
51.	Turn power off and install a temperature probe in front of limit switch button.	—	—	52
52.	Turn power on and cycle unit. Does limit switch open at a temperature at least 10°F below temperature setpoint for limit switch. (EXAMPLE: The setpoint is 220°F , but switch opens at a temperature below 210°F .)	7	53	—
53.	The problem may be related to poor air distribution. Add turning vanes, more supply-air openings, or more return-air openings. Use Appendix E to evaluate.	—	—	48

Fault Code 14

IGNITION LOCKOUT—THIS FAULT INDICATES THE SYSTEM FAILED TO IGNITE GAS AND PROVE FLAME IN 4 ATTEMPTS. CONTROL WILL AUTO-RESET IN 3 HR.

THIS FAULT COULD ALSO INDICATE THE GAS VALVE RELAY GVR ON FURNACE CONTROL BOARD IS STUCK CLOSED OR THERE IS A MISWIRE/SHORT TO GAS VALVE WIRING.

STEP		YES	NO	GO TO
1.	Turn power off and set thermostat to OFF position. Turn power back on and wait a few sec for self test before proceeding to next step.	—	—	2
2.	Does Fault Code 14 flash?	3	6	—
3.	There is a miswire or short to gas valve wiring.	—	—	4
4.	Fix problem.	—	—	5
5.	Go to page number indicated in Index for CLEANUP AND START-UP INSTRUCTIONS.	—	—	INDEX
6.	Does a different fault occur?	7	8	—
7.	Go to page number indicated in Index for the fault code flashed.	—	—	INDEX
8.	Remove blower access panel and depress door switch. Use a piece of tape to hold switch closed.	—	—	9
9.	Jumper R and WW1 thermostat terminals.	—	—	10
10.	Does Fault Code 14 start flashing when low-pressure switch LPS makes?	11	12	—
11.	Replace furnace control board.	—	—	5
12.	Does a different fault occur?	7	13	—
13.	Disconnect jumper wire across R and WW1 thermostat terminals and wait until blower stops.	—	—	14
14.	Jumper R, WW1, and W2 thermostat terminals on furnace control board.	—	—	15
15.	Does Fault Code 14 start flashing when high-pressure switch HPS makes?	16	17	—
16.	The BLUE and GREEN wires to gas valve GV are reversed.	—	—	4
17.	Disconnect jumper wire across R, WW1, and W2 thermostat terminals and wait until inducer stops.	—	—	18
18.	Put setup switch SW-1 in ON position.	—	—	19
19.	Is a Fault Code 34 present in fault history? NOTE: Read fault codes until they repeat. The last fault code that occurred will flash first followed by the lowest number fault code. (EXAMPLE: 14, 14, 34)	20	22	—
20.	Cycle furnace several times to check for intermittent operation.	—	—	21
21.	Check that the GREEN wire is properly connected to furnace sheet metal and clean flame sensor with fine sandpaper.	—	—	5
22.	Go to page number indicated in Index for CLEANUP AND START-UP INSTRUCTIONS. If problem persists on an intermittent basis, replace furnace control board. If problem still persists on an intermittent basis after replacing furnace control board, contact your distributor.	—	—	INDEX

Fault Code 21

INVALID MODEL SELECTION—PERSONALITY CONNECTOR PL5 IS EITHER NOT CONNECTED OR JUMPERED WRONG.

STEP		YES	NO	GO TO
1.	Turn power off and remove blower access panel.	—	—	2
2.	Is personality connector PL5 properly wired per furnace model size chart on wiring diagram?	5	3	—
3.	Replace or rewire personality connector.	—	—	4
4.	Go to page number indicated in Index for CLEANUP AND START-UP INSTRUCTIONS.	—	—	INDEX
5.	Depress door switch. Use a piece of tape to hold switch closed.	—	—	6
6.	Make sure thermostat is calling for heat or jumper R and WW1 thermostat terminals.	—	—	7
7.	Will furnace operate while flashing fault code?	9	8	—
8.	Replace furnace control board.	—	—	4
9.	Are personality plug wires making good connection?	10	11	—
10.	The furnace will operate acceptably; however, a model selection circuit failure has occurred and furnace control board is defaulting to last valid model selection. Board replacement is recommended but not necessary. This fault code will flash continuously.	—	—	4
11.	Fix poor terminal connection or replace personality connector.	—	—	4

Fault Code 22

SETUP ERROR—THIS FAULT INDICATES THAT SETUP SWITCHES SW-1 OR SW-6 ARE ON WHEN THEY SHOULD BE OFF. THE FOLLOWING COMBINATIONS WILL CAUSE THE FAULT:

Thermostat call with SW-1 ON.

Thermostat call with SW-6 ON.

SW-1 and SW-6 both ON together.

STEP		YES	NO	GO TO
1.	Turn power off and remove blower access panel.	—	—	2
2.	Make sure thermostat is NOT calling for heating or cooling. Disconnect all thermostat terminal leads to make sure.	—	—	3
3.	Is setup switch SW-1 in ON position?	4	6	—
4.	Put setup switch SW-1 in OFF position.	—	—	5
5.	Go to page number indicated in Index for CLEANUP AND START-UP INSTRUCTIONS.	—	—	INDEX
6.	Is setup switch SW-6 in ON position?	7	8	—
7.	Put setup switch SW-6 in OFF position.	—	—	5
8.	Replace furnace control board.	—	—	5

Fault Code 23

INVALID BLOWER AIRFLOW SELECTION—THIS FAULT INDICATES IMPROPER A/C OR CF SWITCH SETTING. THE 042 UNITS CAN DELIVER SUFFICIENT AIRFLOW FOR 1-1/2 TO 3-1/2 TONS A/C AND 600 TO 1400 CFM FOR CONTINUOUS FAN. THE 060 UNIT CAN DELIVER SUFFICIENT AIRFLOW FOR 2 TO 5 TONS A/C AND 800 TO 2000 CFM FOR CONTINUOUS FAN. IF FAULT CODE IS FLASHING, UNIT STILL OPERATES, BUT IT DEFAULTS TO CLOSEST ALLOWABLE AIRFLOW.

NOTE: Boards with date codes of 9506 or later will flash fault code and set continuous fan airflow to same airflow as A/C if continuous fan is adjusted to a higher airflow than A/C setting.

STEP		YES	NO	GO TO
1.	Turn power off and remove blower access panel.	—	—	2
2.	Are air conditioning select switches A/C set properly? (See Table 2.)	5	3	—
3.	Set air conditioning select switches A/C for proper tonnage as required by condensing unit.	—	—	4
4.	Go to page number indicated in Index for CLEANUP AND START-UP INSTRUCTIONS.	—	—	INDEX
5.	Are continuous fan select switches CF set properly? (See Table 3.)	7	6	—
6.	Set continuous fan select switches CF for desired airflow. This setting should normally be set to DEFAULT position unless a 2-speed AC/HP is part of system. Use Table 4 for reference on 2-speed AC/HP airflow requirements.	—	—	4
7.	Are continuous fan select switches CF set to a higher airflow than air conditioning select switches A/C? (See Tables 2 and 3.)	6	8	—
8.	Is furnace a 100 size?	11	9	—
9.	The problem is in the A/C or CF selection circuit. The maximum cooling or continuous fan airflow for this unit will be delivered.	—	—	10
10.	Jiggle A/C and CF switches back and forth. If fault code continues to flash, replace furnace control board.	—	—	4
11.	The problem is in the A/C or CF selection circuit. The minimum cooling or continuous fan airflow for this unit will be delivered.	—	—	12
12.	Jiggle A/C and CF switches back and forth. If fault code continues to flash, replace furnace control board.	—	—	4

TABLE 2—AIR CONDITIONING (A/C) AIRFLOW SETUP SWITCH POSITION

AIR CONDITIONER (TONS)	AIRFLOW (CFM)	A/C SWITCH POSITION			ALLOWABLE FURNACE MODEL SETUP			
		A/C-1	A/C-2	A/C-3	042040 3 Tons 1200 CFM	042060 3 Tons 1200 CFM	042080 3 Tons 1200 CFM	060100 5 Tons 2000 CFM
Default	1200 or 2000	OFF	OFF	OFF	—	—	—	—
1-1/2	600	ON	OFF	OFF	X	X	X	—
2	800	OFF	ON	OFF	X	X	X	X
2-1/2	1000	ON	ON	OFF	X	X	X	X
3	1200	OFF	OFF	ON	X	X	X	X
3-1/2	1400	ON	OFF	ON	X	X	X	X
4	1600	OFF	ON	ON	—	—	—	X
5	2000	ON	ON	ON	—	—	—	X

X—Indicates allowable selection.

TABLE 3—CONTINUOUS FAN (CF) AIRFLOW SETUP SWITCH POSITION

CONTINUOUS FAN (CFM)	CF SWITCH POSITION			ALLOWABLE FURNACE MODEL SETUP			
	CF-1	CF-2	CF-3	042040	042060	042080	060100
Default	OFF	OFF	OFF	565*	515*	690*	860*
600	ON	OFF	OFF	X	X	X	—
800	OFF	ON	OFF	X	X	X	X
1000	ON	ON	OFF	X	X	X	X
1200	OFF	OFF	ON	X	X	X	X
1400	ON	OFF	ON	X	X	X	X
1600	OFF	ON	ON	—	—	—	X
2000	ON	ON	ON	—	—	—	X

* 15% additional CFM when Bypass Humidifier switch SW-3 on control board is used.
 — indicates allowable selection.

TABLE 4—TWO-SPEED AC/HP AIRFLOW REQUIREMENTS (CFM)

OUTDOOR UNIT CAPACITY	036	048	060
A/C Setting	3 Tons—1200	4 Tons—1600	5 Tons—2000
CF Setting	800	1000	1000

Fault Code 24

SECONDARY VOLTAGE FUSE IS OPEN—INDICATES FUSE IS OPEN AND THERE IS A SHORT IN LOW-VOLTAGE WIRING.

STEP		YES	NO	GO TO
1.	Turn power off and remove blower access panel.	—	—	2
2.	Is secondary voltage fuse blown? Check continuity to make sure.	5	3	—
3.	Replace furnace control board.	—	—	4
4.	Go to page number indicated in Index for CLEANUP AND START-UP INSTRUCTIONS.	—	—	INDEX
5.	Disconnect all thermostat leads from furnace control board (including HUM terminal) and replace secondary voltage fuse.	—	—	6
6.	Depress door switch. Use a piece of tape to hold switch closed.	—	—	7
7.	Does Fault Code 24 flash?	8	10	—
8.	You have a short circuit in limit switch circuit. This includes limit switch, flame rollout switch, and auxiliary limit switch.	—	—	9
9.	Fix problem and replace secondary voltage fuse if necessary.	—	—	4
10.	Jumper R and W/W1 thermostat terminals on furnace control board.	—	—	11
11.	Does Fault Code 24 occur when W/W1 is energized?	12	16	—
12.	Disconnect jumper wire across R and W/W1 thermostat terminals and replace secondary voltage fuse.	—	—	13
13.	Disconnect PL2 from furnace control board and jumper R and W/W1 thermostat terminals on furnace control board.	—	—	14
14.	Does Fault Code 24 occur when W/W1 is energized?	3	15	—
15.	You have a short circuit in pressure switch circuit.	—	—	9
16.	Does Fault Code 24 occur when low-pressure switch is energized?	17	20	—
17.	Disconnect PL2 from furnace control board.	—	—	18
18.	Do you have continuity between the N.O. (Normally Open) contact on low-pressure switch LPS and chassis ground?	19	3	—
19.	The ORANGE wire from low-pressure switch LPS is shorting to ground. Replace or repair it.	—	—	9
20.	Does Fault Code 24 occur when gas valve GV is energized?	21	28	—
21.	Disconnect jumper wire across R and W/W1 thermostat terminals and replace secondary voltage fuse.	—	—	22
22.	Disconnect BLUE wire to gas valve GV and jumper R and W/W1 thermostat terminals on furnace control board.	—	—	23
23.	Does Fault Code 34 IGNITION PROVING FAULT occur? If not, Fault Code 24 should occur when BLUE wire is energized.	27	24	—
24.	Disconnect PL1 from furnace control board.	—	—	25
25.	Do you have continuity between BLUE wire and chassis ground?	26	3	—
26.	The BLUE wire to gas valve GV is shorting to ground. Replace or repair it.	—	—	9
27.	Replace gas valve GV.	—	—	4
28.	Add a jumper across R and W2 thermostat terminals on furnace control board.	—	—	29
29.	Does Fault Code 24 occur when high-pressure switch HPS is energized?	30	39	—
30.	Disconnect jumper wire across R, W/W1, and W2 thermostat terminals and replace secondary voltage fuse.	—	—	31
31.	Disconnect BROWN wire to gas valve GV and jumper R, W/W1, and W2 thermostat terminals on furnace control board.	—	—	32
32.	Does Fault Code 24 occur when high-pressure switch HPS is energized?	33	27	—
33.	Disconnect PL1 from furnace control board.	—	—	34
34.	Do you have continuity between BROWN wire and chassis ground?	35	36	—
35.	The BROWN wire to gas valve GV is shorting to ground. Replace or repair it.	—	—	9
36.	Disconnect PL2 from furnace control board.	—	—	37
37.	Do you have continuity between the N.O. (Normally Open) contact on high-pressure switch HPS and chassis ground?	38	3	—
38.	The BROWN wire from high-pressure switch HPS is shorting to ground. Replace or repair it.	—	—	9

STEP		YES	NO	GO TO
39.	Disconnect jumper wire across R, W/W1, and W2 thermostat terminals and wait until blower stops.	—	—	40
40.	Jumper R, G, and Y/Y2 thermostat terminals on furnace control board.	—	—	41
41.	Does Fault Code 24 occur when G and Y/Y2 are energized?	3	42	—
42.	Reconnect all thermostat leads (except HUM terminal if used) to furnace control board and operate furnace in heating and cooling mode from thermostat.	—	—	43
43.	Does Fault Code 24 occur during heating cycle?	44	45	—
44.	You have a defective thermostat or a short circuit in wiring between thermostat and furnace.	—	—	9
45.	Does Fault Code 24 occur during cooling cycle?	46	47	—
46.	You have a defective thermostat or a short circuit in wiring between thermostat and outdoor unit.	—	—	9
47.	Does problem usually occur in cooling mode?	48	49	—
48.	Check outdoor unit contactor. Failure to pull in can cause excessive current draw on low-voltage circuit. This can be an intermittent problem.	—	—	9
49.	Reconnect humidifier and check for excessive current draw.	—	—	9

Fault Code 31

HIGH-PRESSURE SWITCH FAULT—THIS FAULT CAN OCCUR UNDER THE SCENARIOS SHOWN BELOW. KEEP IN MIND THAT WHENEVER FURNACE CONTROL BOARD SHUTS UNIT DOWN, GAS SHUTS OFF IMMEDIATELY, INDUCER CONTINUES RUNNING FOR 15 SEC, AND IF BLOWER IS RUNNING, IT REMAINS RUNNING AT LOW-HEAT SPEED OR REDUCES TO LOW-HEAT SPEED FOR SELECTED OFF DELAY.

- **CALL FOR HEAT**—If high-pressure switch HPS is made when a call for heat is initiated, furnace control board flashes Fault Code 31 until switch opens, then cycle begins.

LOW HEAT

1. **PREPURGE AND FIRST 45 SEC AFTER IGNITION**—If high-pressure switch HPS makes during prepurge or just after ignition, furnace control board continues operating until burners are lit and inducer RPM is within 10% of calculated low-fire RPM. If high-pressure switch HPS remains made, furnace control board starts flashing Fault Code 31, shuts unit down, waits 2 minutes, stops flashing Fault Code 31, and restarts heating cycle.
2. **STEADY-STATE**—If high-pressure switch HPS makes during low heat, furnace control board starts flashing Fault Code 31, shuts unit down, waits 2 minutes, stops flashing Fault Code 31, and restarts heating cycle.

HIGH HEAT

1. **PREPURGE**—If high-pressure switch HPS does not make within 45 sec after low-pressure switch LPS makes, furnace control board starts flashing Fault Code 31, shuts unit down, waits 2 minutes, stops flashing Fault Code 31, and restarts heating cycle.
If high-pressure switch HPS opens before ignition, furnace control board starts flashing Fault Code 31 and ramps inducer RPM up until high-pressure switch HPS remakes. When high-pressure switch HPS remakes, furnace control board stops flashing Fault Code 31 and continues heating cycle. If high-pressure switch HPS does not remake within 45 sec after opening, furnace control board continues flashing Fault Code 31, shuts unit down, waits 2 minutes, stops flashing Fault Code 31, and restarts heating cycle.
2. **FIRST MINUTE AFTER IGNITION**—If high-pressure switch HPS opens during first minute after ignition, furnace control board starts flashing Fault Code 31, shuts unit down, waits 2 minutes, stops flashing Fault Code 31, and restarts heating cycle.
3. **STEADY-STATE**—If high-pressure switch HPS opens during high heat, furnace control board starts flashing Fault Code 31 and ramps inducer RPM up until high-pressure switch HPS remakes. When high-pressure switch HPS remakes, furnace control board stops flashing Fault Code 31 and continues heating cycle. If high-pressure switch HPS does not remake within 45 sec after opening, furnace control board continues flashing Fault Code 31, shuts unit down, waits 2 minutes, stops flashing Fault Code 31, and restarts heating cycle.
4. **HIGH FIRE TO LOW FIRE TRANSITION**—When using a 2-stage thermostat and W2 is de-energized, high-pressure switch HPS must open within 45 sec. If high-pressure switch HPS does not open within 45 sec after W2 was de-energized, furnace control board starts flashing Fault Code 31, shuts unit down, waits 2 minutes, stops flashing Fault Code 31, and restarts heating cycle.

STEP		YES	NO	GO TO
1.	Turn power off, remove blower access panel, and disconnect R thermostat lead.	—	—	2
2.	Turn power on and depress door switch. Use a piece of tape to hold switch closed.	—	—	3
3.	Jumper R and W/W1 thermostat terminals on furnace control board.	—	—	4
4.	Observe operation of furnace through 1 heating cycle.	—	—	5
5.	Does fault occur again?	9	6	—
6.	Does a different fault occur?	7	8	—

STEP		YES	NO	GO TO
7.	Go to page number indicated in Index for fault code flashed.	—	—	INDEX
8.	Go to page number indicated in Index for CLEANUP AND START-UP INSTRUCTIONS.	—	—	INDEX
9.	Does fault occur within 5 sec after W/W1 is energized?	10	18	—
10.	Do you have 24v between the N.O. (Normally Open) contact on high-pressure switch HPS and Com on furnace control board?	12	15	—
11.	Replace furnace control board.	—	—	8
12.	Is high-pressure switch HPS wired correctly?	14	13	—
13.	Rewire high-pressure switch HPS per wiring diagram.	—	—	8
14.	Replace pressure switch assembly.	—	—	8
15.	Do you have 24v between connector terminal PL2-4 and Com on furnace control board?	16	11	—
16.	The main harness is miswired.	—	—	17
17.	Fix problem.	—	—	8
18.	Does fault occur during blower on delay period?	19	23	—
19.	Turn power off and disconnect jumper wire across R and W/W1 thermostat terminals.	—	—	20
20.	Turn power on and wait several sec, then jumper R, W/W1, and W2 thermostat terminals on furnace control board.	—	—	21
21.	Does Fault Code 14 start flashing when high-pressure switch HPS makes?	22	14	—
22.	The BLUE and GREEN wires to gas valve GV are reversed.	—	—	17
23.	Does fault occur during low fire after blower turns on?	24	29	—
24.	Turn power off and disconnect jumper wire across R and W/W1 thermostat terminals.	—	—	25
25.	Connect 1 side of a slope manometer with a tee to collector box pressure tap. Connect other side with a tee to gas valve air pressure fitting. Refer to pressure check diagram in Appendix C.	—	—	26
26.	Turn power on and wait several sec, then jumper R and W/W1 thermostat terminals on furnace control board.	—	—	27
27.	Monitor slope manometer. Does pressure reading appear to be stable when fault occurs?	14	28	—
28.	Check for a sag in vent pipe. If problem persists, replace inducer motor.	—	—	8
29.	Disconnect jumper wire across R and W/W1 thermostat terminals and wait until blower stops.	—	—	30
30.	Jumper R, W/W1, and W2 thermostat terminals on furnace control board.	—	—	31
31.	Does high-pressure switch HPS make, then break several times at start of cycle before faulting out?	32	33	—
32.	The problem is either a sag in vent pipe or a clogged drain trap or line.	—	—	17
33.	Does fault occur before main burners ignite?	34	51	—
34.	Do you have 24v between C (Common) on high-pressure switch HPS and Com on furnace control board?	36	35	—
35.	The YELLOW wire to high-pressure switch HPS is not making good connection. Repair or replace it.	—	—	8
36.	Do you have at least 1.90 in. wc pressure drop across heat exchangers when fault occurs? Determine this by connecting 1 side of slope manometer with a tee to collector box pressure tap. Connect other side with a tee to gas valve air pressure fitting. Refer to pressure check diagram in Appendix C.	45	37	—
37.	Is inducer motor MTR1 rotating in direction indicated on inducer housing?	39	38	—
38.	Replace inducer motor or inducer motor assembly.	—	—	8
39.	Turn power off.	—	—	40
40.	Is inducer wheel okay?	42	41	—
41.	If possible, replace inducer wheel. Otherwise, replace inducer motor assembly.	—	—	8
42.	Is there any frost build-up on combustion-air inlet?	43	44	—
43.	The problem is caused by reversed vent and combustion-air pipes or some other moist air entering combustion-air pipe.	—	—	17
44.	You have excessive restriction in combustion-air or vent pipe.	—	—	8
45.	Turn power off and disconnect jumper wire across R, W/W1, and W2 thermostat terminals.	—	—	46
46.	Turn power on and wait several sec, then jumper R, W/W1, and W2 thermostat terminals on furnace control board.	—	—	47
47.	Do you have 24v between connector terminal PL2-4 and Com on furnace control board when fault occurs?	11	48	—
48.	Turn power off.	—	—	49
49.	Do you have continuity across terminal PL2-4 and N.O. (Normally Open) contact on high-pressure switch HPS?	14	50	—
50.	The BROWN wire from high-pressure switch HPS to furnace control board is not making good connection. Repair wire or replace harness.	—	—	8

STEP		YES	NO	GO TO
51.	Turn power off and disconnect jumper wire across R, W/W1, and W2 thermostat terminals.	—	—	52
52.	Connect 1 side of a slope manometer with a tee to collector box pressure tap. Connect other side with a tee to gas valve air pressure fitting. Refer to pressure check diagram in Appendix C.	—	—	53
53.	Turn power on and wait several sec, then jumper R, W/W1, and W2 thermostat terminals on furnace control board.	—	—	54
54.	Monitor slope manometer. Does pressure reading appear to be stable when fault occurs?	55	56	—
55.	Replace pressure switch assembly. If problem persists, check wiring for an intermittent connection in high-pressure switch HPS circuit.	—	—	8
56.	Check for a sag in vent pipe. If problem persists, replace inducer motor.	—	—	8

Fault Code 32

LOW-PRESSURE SWITCH FAULT—THIS FAULT CAN OCCUR UNDER THE SCENARIOS SHOWN BELOW. KEEP IN MIND THAT WHENEVER THE FURNACE CONTROL BOARD SHUTS UNIT DOWN, GAS SHUTS OFF IMMEDIATELY, INDUCER CONTINUES RUNNING FOR 15 SEC, AND IF BLOWER IS RUNNING IT REMAINS RUNNING AT LOW-HEAT SPEED OR REDUCES TO LOW-HEAT SPEED FOR SELECTED OFF DELAY.

- **CALL FOR HEAT**—If low-pressure switch LPS is made when a call for heat is initiated, furnace control board flashes Fault Code 32 until switch opens, then cycle begins.
- **LOW HEAT**

1. **PREPURGE**—If low-pressure switch LPS does not make within 45 sec after call for heat is initiated, furnace control board starts flashing Fault Code 32, shuts unit down, waits 2 minutes, stops flashing Fault Code 32, and restarts heating cycle.

If low-pressure switch LPS opens before ignition, furnace control board starts flashing Fault Code 32 and ramps inducer RPM up until low-pressure switch LPS remakes. When low-pressure switch LPS remakes, furnace control board stops flashing Fault Code 32 and continues heating cycle. If low-pressure switch LPS does not remake within 45 sec after opening, furnace control board continues flashing Fault Code 32, shuts unit down, waits 2 minutes, stops flashing Fault Code 32, and restarts heating cycle.

2. **STEADY-STATE**—If low-pressure switch LPS opens during low heat, furnace control board starts flashing Fault Code 32, shuts unit down, waits 2 minutes, stops flashing Fault Code 32, and restarts heating cycle.

- **HIGH HEAT**

1. **PREPURGE**—If low-pressure switch LPS does not make within 45 sec after call for heat is initiated, furnace control board starts flashing Fault Code 32, shuts unit down, waits 2 minutes, stops flashing Fault Code 32, and restarts heating cycle.

If low-pressure switch LPS opens before ignition, furnace control board starts flashing Fault Code 32, shuts unit down, waits 2 minutes, stops flashing Fault Code 32, and restarts heating cycle.

2. **STEADY-STATE**—If low-pressure switch LPS opens during high heat, furnace control board starts flashing Fault Code 32, shuts unit down, waits 2 minutes, stops flashing Fault Code 32, and restarts heating cycle.

STEP		YES	NO	GO TO
1.	Turn power off, remove blower access panel, and disconnect R thermostat lead.	—	—	2
2.	Turn power on and depress door switch. Use a piece of tape to hold switch closed.	—	—	3
3.	Is inducer motor MTR1 running?	4	5	—
4.	Are inducer motor MTR1 and blower motor MTR2 running?	13	49	—
5.	Jumper R and W/W1 thermostat terminals on furnace control board.	—	—	6
6.	Observe operation of furnace through 1 heating cycle.	—	—	7
7.	Does fault occur again?	11	8	—
8.	Does a different fault occur?	9	10	—
9.	Go to page number indicated in Index for fault code flashed.	—	—	INDEX
10.	Go to page number indicated in Index for CLEANUP AND STARTUP INSTRUCTIONS.	—	—	INDEX
11.	Does fault occur within 5 sec after a call for heat?	12	17	—
12.	Do you have 24v between N.O. (Normally Open) contact on low-pressure switch LPS and Com on furnace control board?	14	47	—
13.	Replace furnace control board.	—	—	10
14.	Is low-pressure switch LPS wired correctly?	16	15	—
15.	Rewire low-pressure switch LPS per wiring diagram.	—	—	10

STEP		YES	NO	GO TO
16.	Replace pressure switch assembly.	—	—	10
17.	At start of cycle as inducer is ramping up, does low-pressure switch LPS make then break?	34	18	—
18.	Does fault occur 45 sec after call for heat?	50	41	—
19.	Do you have 24v between C (Common) on low-pressure switch LPS and Com on furnace control board?	24	20	—
20.	Do you have 24v between connector terminal PL2-1 and Com on furnace control board?	21	13	—
21.	Turn power off.	—	—	22
22.	Double check continuity between C (Common) on low-pressure switch LPS and connector terminal PL2-1.	—	—	23
23.	The YELLOW wire to low-pressure switch LPS is not making good connection. Repair or replace it.	—	—	10
24.	Do you have at least 0.95 in. wc pressure drop (0.75 in. wc on trophy unit) across heat exchangers when fault occurs? Determine this by connecting 1 side of a slope manometer with a tee to collector box pressure tap. Connect other side with a tee to gas valve air pressure fitting. Refer to pressure check diagram in Appendix C.	35	25	—
25.	Is inducer motor MTR1 rotating in direction indicated on Inducer housing?	28	26	—
26.	Replace inducer motor or inducer motor assembly.	—	—	10
27.	Fix problem.	—	—	10
28.	Turn power off.	—	—	10
29.	Is inducer blower wheel okay?	—	—	29
30.	If possible, replace inducer blower wheel. Otherwise, replace inducer motor assembly.	31	30	—
31.	Is there any frost build-up on combustion-air inlet?	—	—	10
32.	The problem is caused by reversed vent and combustion-air pipes or some other moist air entering combustion-air pipe.	32	33	—
33.	You have excessive restriction in combustion-air or vent pipe.	—	—	27
34.	The problem is either a sag in vent pipe or a clogged drain trap or line.	—	—	10
35.	Turn power off and disconnect jumper wire across R and W/W1 thermostat terminals.	—	—	27
36.	Turn power on and wait several sec, then jumper R and W/W1 thermostat terminals on furnace control board.	—	—	36
37.	Do you have 24v between connector terminal PL2-2 and Com on furnace control board when fault occurs?	—	—	37
38.	Turn power off.	13	38	—
39.	Do you have continuity across terminal PL2-2 and N.O. (Normally Open) contact on low-pressure switch LPS?	—	—	39
40.	The ORANGE wire from low-pressure switch LPS to furnace control board is not making good connection. Repair wire or replace harness.	16	40	—
41.	Turn power off and disconnect jumper wire across R and W/W1 thermostat terminals.	—	—	10
42.	Connect 1 side of a slope manometer with a tee to collector box pressure tap. Connect other side with a tee to gas valve air pressure fitting. Refer to pressure check diagram in Appendix C.	—	—	42
43.	Turn power on and wait several sec, then jumper R and W/W1 thermostat terminals on furnace control board.	—	—	43
44.	Monitor slope manometer. Does pressure reading appear to be stable when fault occurs?	—	—	44
45.	Replace pressure switch assembly. If problem persists, check wiring for an intermittent connection in low-pressure switch LPS circuit.	45	46	—
46.	Check for a sag in vent pipe. If problem persists, replace inducer motor.	—	—	10
47.	Do you have 24v between connector terminal PL2-2 and Com on furnace control board?	—	—	10
48.	The main harness is miswired.	48	13	—
49.	Check Inducer PW line. To do this, disconnect PL7 from inducer motor and connect a DC voltmeter across terminals PL7-2 BROWN (+) and PL7-10 YELLOW (-) then run COMPONENT TEST by turning setup switch SW-6 ON. Does voltage across PL7-2 and PL7-10 change between states as shown below? • State 1—OFF (-0.1 — 0.1 vdc) • State 2—LOW (6.0 — 7.0 vdc) • State 3—HIGH (10.5 — 11.5 vdc)	—	—	27
50.	Does inducer motor MTR1 turn on?	26	13	—
51.	Do you have less than 90 vac between I1 and I2 on furnace control board?	19	51	—
52.		53	52	—

STEP		YES	NO	GO TO
52.	Check Inducer PW line. To do this, disconnect PL7 from inducer motor and connect a DC voltmeter across terminals PL7-2 BROWN (+) and PL7-10 YEL-LOW (-) then run COMPONENT TEST by turning setup switch SW-6 ON. Does voltage across PL7-2 and PL7-10 change between states as shown below? <ul style="list-style-type: none"> • State 1—OFF (-0.1 — 0.1 vdc) • State 2—LOW (6.0 — 7.0 vdc) • State 3—HIGH (10.5 — 11.5 vdc) 	26	13	—
53.	Make sure wire gage between main fuse box and furnace complies with wire size specification in Installation, Start-Up, and Operating Instructions.	—	—	27

Fault Code 33

LIMIT SWITCH FAULT—THIS FAULT INDICATES THE LIMIT SWITCH, ROLLOUT SWITCH, OR AUXILIARY LIMIT SWITCH IS OPEN OR UNIT IS OPERATING IN HIGH-HEAT-ONLY MODE DUE TO 2 SUCCESSIVE LOW-HEAT LIMIT TRIPS.

STEP		YES	NO	GO TO
1.	Turn power off, remove blower access panel, and disconnect R thermostat lead.	—	—	2
2.	Turn power on and depress door switch. Use a piece of tape to hold switch closed.	—	—	3
3.	Is the fault code flashing?	11	4	—
4.	Set thermostat to call for heat or jumper R and W/W1 thermostat terminals.	—	—	5
5.	Observe operation of furnace for next 25 minutes.	—	—	6
6.	Does fault occur again?	40	7	—
7.	Does a different fault occur?	8	9	—
8.	Go to page number indicated in Index for fault code flashed.	—	—	INDEX
9.	Go to page number indicated in Index for CLEANUP AND START-UP INSTRUCTIONS.	—	—	INDEX
10.	Consider this fault like a Fault Code 13 and go to page number indicated in Index for Fault Code 13.	—	—	INDEX
11.	Do you have 24v between terminals PL1-9 and C?	13	12	—
12.	Replace furnace control board.	—	—	9
13.	Do you have 24v between terminals PL1-11 and C?	12	15	—
14.	You have an open RED wire or bad terminal in limit circuit. Repair or replace it.	—	—	9
15.	Turn power off.	—	—	16
16.	Do you have continuity across limit switch LS?	20	17	—
17.	Wait for unit to cool then recheck for continuity across limit switch LS.	—	—	18
18.	Do you have continuity across limit switch LS?	20	19	—
19.	Replace limit switch.	—	—	9
20.	Do you have continuity across flame rollout switch FRS?	28	21	—
21.	Can flame rollout switch FRS be reset?	23	22	—
22.	Replace flame rollout switch.	—	—	9
23.	Reset flame rollout switch FRS, turn power on, and observe furnace operation for (2) 15 minute cycles.	—	—	24
24.	Does flame rollout switch trip again?	26	25	—
25.	Does a different fault occur?	8	9	—
26.	You have inadequate combustion-air supply. This may be caused by: <ul style="list-style-type: none"> • Reversed vent and combustion-air pipes. • Poor burner, manifold, or orifice alignment. • Leak somewhere between primary and secondary heat exchangers. • Leak in secondary heat exchanger. 	—	—	27
27.	Fix problem.	—	—	9
28.	Do you have continuity across auxiliary limit switch ALS?	14	29	—
29.	Can auxiliary limit switch ALS be reset?	31	30	—
30.	Replace auxiliary limit switch.	—	—	9
31.	Reset auxiliary limit switch ALS, replace blower access panel, turn power on, set thermostat to call for heat or jumper R and W/W1 thermostat terminals, and observe furnace operation for 15 minutes.	—	—	32
32.	Does fault occur again?	38	33	—
33.	Does a different fault occur?	8	34	—
34.	Is this unit in downflow or horizontal position?	35	9	—

STEP		YES	NO	GO TO
35.	Disconnect R thermostat lead, wait for blower to stop, and continue to observe unit for 5 more minutes.	—	—	36
36.	Does fault occur after blower stops?	37	9	—
37.	Increase blower off delay time to 225 sec by putting both setup switches SW-7 and SW-8 in ON position.	—	—	27
38.	Does furnace have proper limit switch, limit shield, blower baffle (if used), rear air baffle (if used), and auxiliary limit switch? If so, are limit switch, limit shield, and heat exchangers properly aligned?	39	27	—
39.	Change limit switch first. If problem still exists, replace auxiliary limit switch. One of these switches is out of calibration.	—	—	9
40.	Does fault occur during low fire?	41	42	—
41.	On the third burner cycle, unit will run in high-fire mode and flash fault code continuously. The unit is locked into high-fire-only mode. Verify the following before going to Step 10: <ul style="list-style-type: none"> • If unit has a bypass humidifier, make sure setup switch SW-3 is in ON position. • If unit is installed in a zone system, make sure setup switch SW-5 is in ON position. • Check low-fire rate. Clock input rate. DO NOT use manifold pressure method unless using propane. 	—	—	10
42.	Verify the following before going to Step 10: <ul style="list-style-type: none"> • If unit is installed in a zone system, make sure setup switch SW-5 is in ON position. • Check high-fire rate. Clock input rate. DO NOT use manifold pressure method unless using propane. 	—	—	10

Fault Code 34

IGNITION PROVING FAULT—THIS FAULT CAN INDICATE 1 OF THE FOLLOWING:

- Flame was not sensed during trial for ignition period. The control will repeat ignition sequence 3 more times before going into Fault 14—IGNITION LOCKOUT.
- The flame signal was lost after trial for ignition period.
- The flame signal was sensed while gas valve was de-energized. The inducer will run at full speed until fault is cleared.

STEP		YES	NO	GO TO
1.	Turn power off, remove blower access panel, and disconnect R thermostat lead from furnace control board.	—	—	2
2.	Turn power on and depress door switch. Use a piece of tape to hold switch closed.	—	—	3
3.	Make sure thermostat is NOT calling for heat and reconnect R thermostat lead to furnace control board. Observe unit for 15 minutes. Does inducer motor ever turn on at full speed while furnace control board flashes Fault Code 34?	4	5	—
4.	Replace furnace control board. Make sure it has a date code 9405 or later.	—	—	12
5.	Disconnect R thermostat lead from furnace control board and jumper R and W/W1 thermostat terminals on furnace control board.	—	—	6
6.	Observe operation of furnace through 1 heating cycle.	—	—	7
7.	Does fault occur again?	13	8	—
8.	Does a different fault occur?	9	10	—
9.	Go to page number indicated in Index for fault code flashed.	—	—	INDEX
10.	Disconnect jumper wire across R and W/W1 thermostat terminals. Does fault occur now?	11	12	—
11.	Replace gas valve.	—	—	12
12.	Go to page number indicated in Index for CLEANUP AND START-UP INSTRUCTIONS.	—	—	INDEX
13.	Turn power off and disconnect jumper wire across R and W/W1 thermostat terminals.	—	—	14
14.	Turn power on and wait several sec before proceeding to next step.	—	—	15
15.	Check hot surface ignitor. To do this, put setup switch SW-6 for COMPONENT TEST in ON position. Does ignitor glow orange/white hot by end of 15-sec warm-up period?	20	16	—

STEP		YES	NO	GO TO
16.	Disconnect PL4 from furnace control board. Connect an AC voltmeter across PL4-1 and PL4-2 on furnace control board. Repeat COMPONENT TEST by turning setup switch SW-6 OFF and then back ON. Do you see 120 vac across PL4-1 and PL4-2 during 15-sec warm-up period?	18	17	—
17.	Replace furnace control board.	—	—	12
18.	Check continuity in harness and ignitor. Replace defective component.	—	—	19
19.	Fix problem.	—	—	8
20.	Put setup switch SW-6 for COMPONENT TEST in OFF position.	—	—	21
21.	Jumper R and W/W1 thermostat terminals on furnace control board.	—	—	22
22.	Connect an AC voltmeter across BLUE and GREEN wires to gas valve GV. Does gas valve GV receive 24v?	26	23	—
23.	Turn power off.	—	—	24
24.	Do you have continuity across the following connections: • PL1-2 and BLUE wire at gas valve GV. • PL1-7 and GREEN wire at gas valve GV.	17	25	—
25.	The BLUE or GREEN wire from furnace control board to gas valve GV is not making good connection. Repair wire(s) or replace harness.	—	—	12
26.	Does gas valve open and allow gas to flow?	28	27	—
27.	Are all manual gas cocks in ON position?	11	19	—
28.	Do main burners ignite?	30	29	—
29.	Check for the following: • Inadequate flame carryover or rough ignition. • Low inlet gas pressure.	—	—	19
30.	Do main burners stay on?	40	31	—
31.	Turn power off and disconnect Jumper wire across R and W/W1 thermostat terminals.	—	—	32
32.	Connect a DC microammeter in series with flame sensor wire.	—	—	33
33.	Turn power on and wait several sec then jumper R and W/W1 thermostat terminals on furnace control board.	—	—	34
34.	Is DC current below 0.5 microamps?	36	35	—
35.	Check connections and recheck current. If current is near typical value and control will not stay on, replace furnace control board.	—	—	12
36.	Clean flame sensor with fine sandpaper and recheck current. Current is typically 4.0 to 6.0 microamps.	—	—	37
37.	Is current near typical value?	39	38	—
38.	Replace electrode.	—	—	12
39.	Will main burners ignite and stay on?	12	17	—
40.	Do you have combustion pulsations?	41	47	—
41.	Make sure perforated disks are in combustion-air vent inlet.	—	—	42
42.	Check pressure tubing going to gas valve air pressure fitting for kinks.	—	—	43
43.	Remove gas valve air pressure fitting and check gas valve for blockage.	—	—	44
44.	Ensure vent and combustion-air pipes are not reversed.	—	—	45
45.	Check burner orifice size and alignment.	—	—	46
46.	Add restriction to combustion-air pipe or lengthen it a few feet if possible.	—	—	12
47.	Jumper R and W2 thermostat terminals on furnace control board.	—	—	48
48.	Do you have combustion oscillations in high fire?	41	12	—

Fault Code 41

BLOWER OUTSIDE VALID SPEED RANGE—THIS FAULT INDICATES 1 OF THE FOLLOWING:

- Blower motor speed cannot be maintained within 10% of calculated speed over a 30-sec period.
- Blower motor speed is less than 250 RPM or greater than 1300 RPM for more than 10 sec.

STEP		YES	NO	GO TO
1.	Turn power off, remove blower access panel, and disconnect R thermostat lead from furnace control board.	—	—	2
2.	Turn power on and depress door switch. Use a piece of tape to hold switch closed.	—	—	3
3.	Jumper R and W/W1 thermostat terminals on furnace control board.	—	—	4
4.	Observe operation of furnace for next 8 minutes or until fault occurs.	—	—	5

STEP		YES	NO	GO TO
5.	Does Fault Code 44 flash twice followed by Fault Code 41?	6	7	—
6.	After about 10 minutes of operation, furnace will lock out and flash Fault Code 12. Go to page number indicated in Index for Fault Code 12.	—	—	INDEX
7.	Does only Fault Code 41 flash?	11	8	—
8.	Does a different fault occur?	9	25	—
9.	Go to page number indicated in Index for fault code flashed.	—	—	INDEX
10.	Go to page number indicated in Index for CLEANUP AND STARTUP INSTRUCTIONS.	—	—	INDEX
11.	Does blower motor suddenly stop 10 sec before fault is signaled?	12	21	—
12.	Turn power off and disconnect jumper wire across R and W/W1 thermostat terminals.	—	—	13
13.	Put setup switch SW-4 labeled EMER. HEAT in ON position.	—	—	14
14.	Turn power on and wait several sec, then jumper R and W/W1 thermostat terminals on furnace control board.	—	—	15
15.	Check connectors PL3, PL10, PL11, PL12, PL13, B1, and B2.	—	—	16
16.	Does motor operate intermittently in response to connectors and wires being moved?	17	18	—
17.	Fix problem.	—	—	10
18.	Does blower motor suddenly stop?	19	20	—
19.	Replace blower motor. If problem still persists after replacing blower motor, contact your distributor.	—	—	INDEX
20.	Replace furnace control board.	—	—	10
21.	Turn power off and disconnect jumper wire across R and W/W1 thermostat terminals.	—	—	22
22.	Check connectors PL3, PL10, and PL13 for possible intermittent connection of ORANGE and VIOLET wires.	—	—	23
23.	Are ORANGE and VIOLET wires from PL3 and PL13 making good contact?	24	17	—
24.	Replace blower motor.	—	—	10
25.	Go to page number indicated in Index for CLEANUP AND STARTUP INSTRUCTIONS. If problem persists on an intermittent basis, replace blower motor. If problem still persists on an intermittent basis after replacing blower motor, contact your distributor.	—	—	INDEX

Fault Code 42

INDUCER OUTSIDE VALID SPEED RANGE—THIS FAULT INDICATES THAT INDUCER MOTOR IS NOT OPERATING AT CALCULATED RPM OR HAS NOT STARTED WITHIN 10 SEC AFTER A CALL FOR HEAT.

STEP		YES	NO	GO TO
1.	Turn power off, remove blower access panel, and disconnect all thermostat leads from furnace control board.	—	—	2
2.	Turn power on and depress door switch. Use a piece of tape to hold switch closed.	—	—	3
3.	Jumper R and W/W1 thermostat terminals on furnace control board.	—	—	4
4.	Observe operation of furnace for next 8 minutes or until fault occurs.	—	—	5
5.	Does fault occur again?	9	6	—
6.	Does a different fault occur?	7	60	—
7.	Go to page number indicated in Index for fault code flashed.	—	—	INDEX
8.	Go to page number indicated in Index for CLEANUP AND STARTUP INSTRUCTIONS.	—	—	INDEX
9.	Does fault occur within 11 sec after a call for heat?	52	35	—
10.	Do you have 120v between I1 and I2 on furnace control board?	11	14	—
11.	Do you have 120v between terminals PL7-6 and PL7-12?	13	12	—
12.	You have an open wire or bad terminal on either the BLACK or WHITE wire between furnace control board and inducer motor MTR1.	—	—	14
13.	Are all pins and wire leads intact on connectors between furnace control board and inducer motor?	15	14	—
14.	Fix problem.	—	—	8
15.	Turn power off and disconnect jumper wire across R and W/W1 thermostat terminals. Turn power on and wait a few sec for self test before proceeding to next step.	—	—	16

STEP		YES	NO	GO TO
16.	Put setup switch SW-4 for EMER. HEAT in ON position.	—	—	17
17.	Jumper R and W/W1 thermostat terminals on furnace control board.	—	—	18
18.	Does inducer motor turn on?	30	19	—
19.	Does inducer wheel rub against inducer housing?	14	20	—
20.	Turn power off.	—	—	21
21.	Does inducer wheel turn freely?	24	22	—
22.	Replace inducer motor or inducer motor assembly.	—	—	8
23.	Replace furnace control board.	—	—	8
24.	Disconnect jumper wire across R and W/W1 thermostat terminals and put setup switch SW-4 for EMER. HEAT in OFF position.	—	—	25
25.	Turn power on and wait a few sec for self test before proceeding to next step.	—	—	26
26.	Check 12-vdc line. To do this, connect a DC voltmeter across terminals PL1-6 BROWN (+) and PL1-7 GREEN (-). Is voltage across BROWN and GREEN wires 11.5 — 12.5 vdc?	27	23	—
27.	Turn power off.	—	—	28
28.	Do you have continuity between PL7-2 and PL1-6?	22	29	—
29.	You have an open wire or bad terminal on BROWN wire between connectors PL7 and PL1.	—	—	14
30.	Disconnect jumper wire across R and W/W1 thermostat terminals and put setup switch SW-4 for EMER. HEAT in OFF position.	—	—	31
31.	Check RPM feedback line. To do this, connect a DC voltmeter across terminals PL1-6 BROWN (+) and PL1-5 ORANGE (-), then put setup switch SW-6 for COMPONENT TEST in ON position. Does voltage across BROWN and ORANGE wires change between states as shown below? <ul style="list-style-type: none"> • State 1—OFF (11.5 — 12.5 vdc) • State 2—LOW (10.2 — 11.2 vdc) • State 3—HIGH (8.4 — 9.4 vdc) 	23	32	—
32.	Turn power off.	—	—	33
33.	Do you have continuity between PL7-1 and PL1-5?	22	34	—
34.	You have an open wire or bad terminal on ORANGE wire between connectors PL7 and PL1.	—	—	14
35.	Does fault occur a few sec after low-pressure switch LPS makes? NOTE: Check for 24v between the N.O. (Normally Open) contact on low-pressure switch LPS and Com on furnace control board to know when low-pressure switch LPS makes.	36	48	—
36.	Is inducer motor rotating in direction shown on inducer housing?	37	22	—
37.	Turn power off and disconnect jumper wire across R and W/W1 thermostat terminals.	—	—	38
38.	Connect 1 side of a slope manometer with a tee to collector box pressure tap. Connect other side with a tee to gas valve air pressure fitting. Refer to pressure check diagram in Appendix C.	—	—	39
39.	Turn power on and wait several sec, then jumper R and W/W1 thermostat leads on furnace control board.	—	—	40
40.	Do you have more than 1.0 in. wc pressure drop (0.80 in. wc on trophy unit) across heat exchangers when low-pressure switch LPS makes? NOTE: Check for 24v between the N.O. (Normally Open) contact on low-pressure switch LPS and Com on furnace control board to know when low-pressure switch LPS makes.	47	41	—
41.	Turn power off.	—	—	42
42.	Is inducer blower wheel okay?	44	43	—
43.	If possible, replace inducer wheel. Otherwise, replace inducer motor assembly.	—	—	8
44.	Is there any frost build-up on combustion-air inlet?	45	46	—
45.	The problem is caused by reversed vent and combustion-air pipes or some other moist air entering combustion-air pipe.	—	—	14
46.	You have excessive restriction in combustion-air or vent pipe.	—	—	14
47.	Replace pressure switch assembly.	—	—	8
48.	Does fault occur just before blower motor turns on?	49	51	—
49.	Is unit a trophy unit?	50	47	—
50.	Reduce combustion-air and vent pipe to 1-1/2-in. size or add restriction to combustion-air pipe. If neither works, replace pressure switch assembly.	—	—	14
51.	Replace furnace control board. If problem still persists after replacing furnace control board, contact your distributor.	—	—	INDEX
52.	Turn power off and disconnect jumper wire across R and W/W1 thermostat terminals.	—	—	53
53.	Turn power on and wait several sec before proceeding to next step.	—	—	54
54.	Disconnect collector box tube to pressure switch assembly.	—	—	55
55.	Jumper R and W/W1 thermostat terminals on furnace control board.	—	—	56
56.	Does Fault Code 42 occur within 11 sec after a call for heat?	57	58	—

STEP		YES	NO	GO TO
57.	Reconnect collector box tube to pressure switch assembly.	—	—	10
58.	Reconnect collector box tube to pressure switch assembly.	—	—	36
59.	Go to page number indicated in Index for CLEANUP AND STARTUP INSTRUCTIONS. If problem persists on an intermittent basis, contact your distributor.	—	—	INDEX
60.	Turn power off and disconnect jumper wire across R and W/W1 thermostat terminals.	—	—	61
61.	Turn power on and wait several sec, then jumper R, W/W1, and W2 thermostat terminals on furnace control board.	—	—	62
62.	Does fault occur a few sec after high-pressure switch HPS makes? NOTE: Check for 24v between the N.O. (Normally Open) contact on high-pressure switch HPS and Com on furnace control board to know when high-pressure switch HPS makes.	63	67	—
63.	Turn power off and disconnect jumper wire across R, W/W1, and W2 thermostat terminals.	—	—	64
64.	Connect 1 side of a slope manometer with a tee to collector box pressure tap. Connect other side with a tee to gas valve air pressure fitting. Refer to pressure check diagram in Appendix C.	—	—	65
65.	Turn power on and wait several sec, then jumper R, W/W1, and W2 thermostat terminals on furnace control board.	—	—	66
66.	Do you have more than 1.9 in. wc pressure drop across heat exchangers when high-pressure switch HPS makes? NOTE: Check for 24v between the N.O. (Normally Open) contact on high-pressure switch HPS and Com on furnace control board to know when high-pressure switch HPS makes.	47	44	—
67.	Does fault occur a few sec after main burners ignite?	63	59	—

Fault Code 43

PRESSURE SWITCH CALIBRATION FAULT—INDICATES LOW-PRESSURE SWITCH LPS AND HIGH-PRESSURE SWITCH HPS "MAKE" POINTS DURING HIGH-HEAT PURGE ARE NOT WITHIN CALIBRATION RANGE. THIS IS DETERMINED BY READING INDUCER MOTOR RPM WHEN LOW-PRESSURE SWITCH LPS AND HIGH-PRESSURE SWITCH HPS MAKE. THEN THE FOLLOWING COMPARISON IS MADE:

$$0.55 < \frac{\text{RPM (low)}}{\text{RPM (high)}} < 0.90$$

IF THIS RELATIONSHIP IS NOT WITHIN RANGE SPECIFIED, FURNACE CONTROL BOARD STARTS FLASHING FAULT CODE 43, SHUTS UNIT DOWN (INDUCER RUNS FOR 15 SEC), WAITS 2 MINUTES, STOPS FLASHING FAULT CODE, AND RESTARTS HEATING CYCLE.

STEP		YES	NO	GO TO
1.	Turn power off, remove blower access panel, and disconnect all thermostat leads from furnace control board.	—	—	2
2.	Turn power on and depress door switch. Use a piece of tape to hold switch closed.	—	—	3
3.	Jumper R, W/W1, and W2 thermostat terminals on furnace control board.	—	—	4
4.	Observe operation of furnace for several minutes or until fault occurs.	—	—	5
5.	Does fault occur again?	9	6	—
6.	Does a different fault occur?	7	8	—
7.	Go to page number indicated in Index for fault code flashed.	—	—	INDEX
8.	Go to page number indicated in Index for CLEANUP AND START-UP INSTRUCTIONS.	—	—	INDEX
9.	Is collector box and inducer housing properly draining condensate?	11	25	—
10.	Fix problem.	—	—	8
11.	Are pressure switches wired correctly?	13	10	—
12.	Replace pressure switch assembly.	—	—	8
13.	Do you have 24v between C (Common) on low-pressure switch LPS and Com on furnace control board?	15	14	—
14.	The YELLOW wire to low-pressure switch LPS is not making good connection. Repair wire or replace harness.	—	—	8

STEP		YES	NO	GO TO
15.	Turn power off and disconnect jumper wire across R, W/W1, and W2 thermostat terminals. Turn power on and wait a few sec for self test, then reconnect jumper across R, W/W1, and W2 thermostat terminals.	—	—	16
16.	Do you have 24v between connector terminal PL2-2 and Com on furnace control board when fault occurs?	21	18	—
17.	Replace furnace control board.	—	—	8
18.	Turn power off.	—	—	19
19.	Do you have continuity across terminal PL2-2 and N.O. (Normally Open) contact on low-pressure switch LPS?	12	20	—
20.	The ORANGE wire from low-pressure switch LPS to furnace control board is not making good connection. Repair wire or replace harness.	—	—	8
21.	Turn power off and disconnect jumper wire across R, W/W1, and W2 thermostat terminals. Disconnect BROWN wire from N.O. (Normally Open) contact on high-pressure switch HPS. Turn power on and wait a few sec for self test, then reconnect jumper across R and W/W1 thermostat terminals.	—	—	22
22.	Does a Fault Code 32 occur?	17	23	—
23.	Reconnect BROWN wire to N.O. (Normally Open) contact on high-pressure switch HPS.	—	—	24
24.	The problem may be caused by a sag in vent pipe. If this is not the problem and fault still occurs, replace pressure switch assembly.	—	—	8
25.	The vent tube to drain trap, drain trap, or drain line is clogged.	—	—	10

Fault Code 44

BLOWER CALIBRATION FAULT—THIS FAULT INDICATES THAT CALCULATED BLOWER MOTOR SPEED IS BELOW 250 OR ABOVE 1300 RPM. WHEN FAULT CODE 44 OCCURS IN HEATING, COOLING, OR CONTINUOUS FAN MODE, UNIT OPERATES AS SHOWN BELOW. KEEP IN MIND THAT WHENEVER FURNACE CONTROL BOARD SHUTS UNIT DOWN IN HEATING MODE, GAS SHUTS OFF IMMEDIATELY, INDUCER CONTINUES RUNNING FOR 15 SEC, AND BLOWER RUNS AT DEFAULT (OR PREVIOUS) SPEED CONTROL SIGNAL FOR SELECTED OFF DELAY.

- **HEATING**—During a call for heat, the desired low-heat and high-heat blower RPMs are calculated at the same time. If desired low-heat blower RPM is less than 250 or greater than 1300 RPM, furnace control board starts flashing Fault Code 44, shuts unit down, waits 2 minutes, stops flashing Fault Code 44, and restarts heating cycle. If this happens on 2 consecutive cycles, furnace control board locks out on Fault Code 12. During this sequence, it is possible for furnace control board to start flashing Fault Code 41 instead of Fault Code 44. This indicates that blower calibration failed and blower speed during off delay is out of range.

When unit is operating in low heat and furnace control board (date code 9505 or earlier) is flashing Fault Code 44, it indicates that desired high-heat blower RPM is greater than 1300 RPM, and unit remains running in low fire-mode for rest of heating cycle.

When unit is operating in high heat and furnace control board (date code 9506 or later) is flashing Fault Code 44, it indicates that desired high-heat blower RPM is greater than 1300 RPM, but furnace control board is running blower at default speed of 1200 RPM. Under this condition, the high-fire temperature rise could be outside rise range and can cause limit cycling to occur.

- **COOLING**—If desired cooling blower RPM is less than 250 or greater than 1300 RPM, furnace control board starts flashing Fault Code 44 and runs at default (or previous) cooling speed control signal for rest of cooling cycle. During this sequence, it is possible for furnace control board to start flashing Fault Code 41 instead of Fault Code 44. This indicates that blower calibration failed and blower speed for cooling is also out of range.
- **CONTINUOUS FAN**—If desired continuous fan blower RPM is less than 250 or greater than 1300 RPM, furnace control board will start flashing Fault Code 44 and run at default (or previous) continuous fan speed control signal for the rest of continuous fan cycle. During this sequence, it is possible for furnace control board to start flashing Fault Code 41 instead of Fault Code 44. When this happens, it indicates blower calibration failed and blower speed for continuous fan is also out of range.

STEP		YES	NO	GO TO
1.	Turn power off, wait 30 sec, then restore power. Reset thermostat. Observe operation of furnace through 1 heating cycle. NOTE: Blower access panel must be in place.	—	—	2
2.	Does Fault Code 44 flash twice followed by Fault Code 41?	3	4	—
3.	Eventually furnace will lock out on Fault Code 12 given enough time. Go to page number indicated in Index for Fault Code 12.	—	—	INDEX
4.	Does only Fault Code 44 occur?	8	5	—
5.	Does a different fault occur?	6	11	—
6.	Go to page number indicated in Index for fault code flashed.	—	—	INDEX
7.	Go to page number indicated in Index for CLEANUP AND START-UP INSTRUCTIONS.	—	—	INDEX

STEP		YES	NO	GO TO
8.	Does unit operate in low fire while flashing Fault Code 44?	9	3	—
9.	You have excessive restriction in air delivery system. Check filter(s) and ductwork. If problem still persists, replace furnace control board. Make sure replacement board has a date code of 9506 or later. This new furnace control board will allow unit to run in high fire when necessary. See description of operation at start of Fault Code 44. If problem still persists, use Appendix E to evaluate.	—	—	10
10.	Fix problem.	—	—	7
11.	Turn power off, wait 30 sec, then restore power. Reset thermostat. Observe operation of furnace through 1 cooling cycle. NOTE: Blower access panel must be in place.	—	—	12
12.	Does Fault Code 44 occur?	13	14	—
13.	You have excessive restriction in air delivery system. Check filter(s) and ductwork. Furnace blower will operate in cooling mode at default speed. Check outdoor unit suction pressure and verify charge to determine if indoor airflow is sufficient. If not, refer to Appendix E to evaluate.	—	—	10
14.	Turn power off, wait 30 sec, then restore power. Reset thermostat. Observe operation of furnace after it goes into high fire. NOTE: Blower access panel must be in place.	—	—	15
15.	Does unit operate in high fire while flashing Fault Code 44?	16	7	—
16.	You have excessive restriction in air delivery system. Check filter(s) and ductwork. Furnace blower will operate in high-fire speed at 1200 RPM. Check temperature rise of furnace and make sure unit does not trip primary limit. If it does, refer to Appendix E to evaluate.	—	—	10

CLEANUP AND START-UP INSTRUCTIONS

- Start furnace using procedure outlined on Lighting Instructions attached to furnace. Observe operation of furnace through at least 1 complete heating cycle controlled from room thermostat. Observe each cycle for 20 minutes or until a fault code is flashed. If a fault occurs, refer to the Index.
- Recycle as necessary and check thermostat heat anticipator setting, gas input rates, and temperature rises. These procedures are outlined in Installation, Start-Up, and Operating Instructions.
- Check operation of safety devices: pressure switches, limit switch, and flame roll out switch.
- Put setup switch SW-1 in ON position and jumper R, W/W1, and Y/Y2 terminals on furnace control board simultaneously to clear fault history.
- Put setup switch SW-1 in OFF position.
- Put all setup switches in their proper positions.
- Remove tape from the door switch.
- Replace thermostat leads (if necessary).
- Set thermostat in AUTO position, calling for heat.
- Set thermostat to desired temperature.
- Replace blower access panel and main furnace door. Clean up.

Appendix A

Board Layout and Schematic

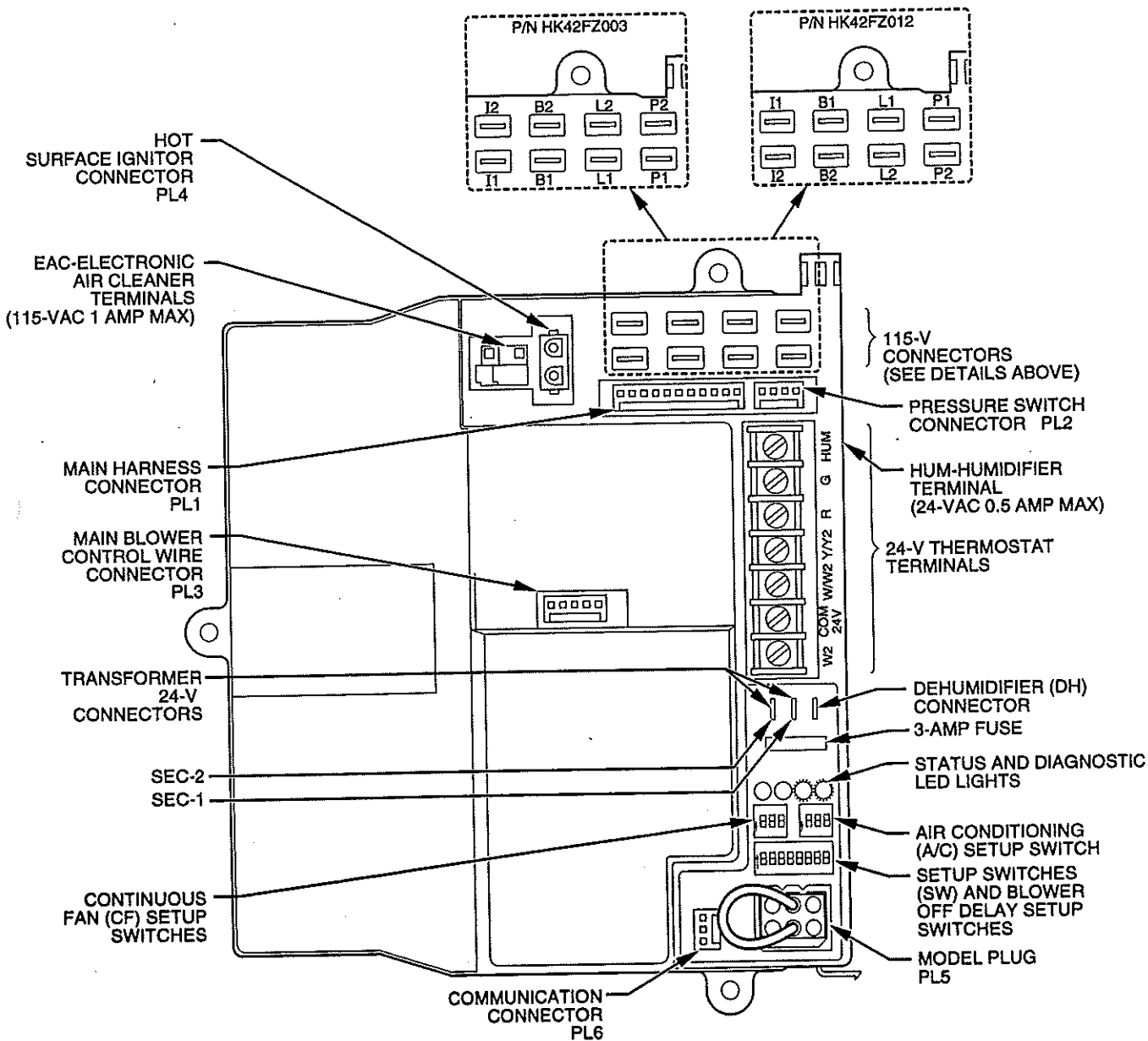

Control Center

A95093

NOTE: If wiring schematic on unit is different from one shown below, use wiring schematic on unit.

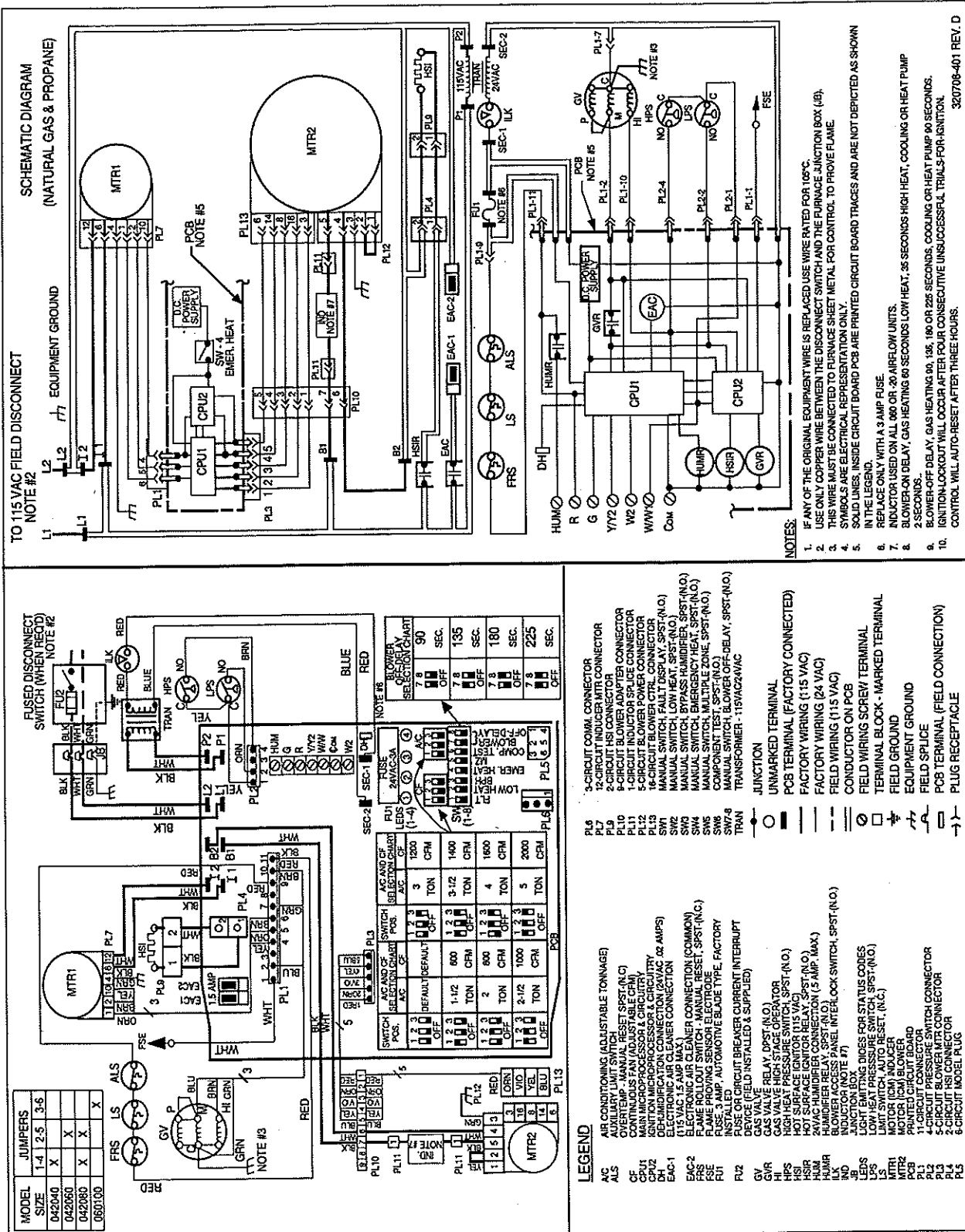

A93061

Wiring Schematic

Appendix B

Isolation Circuits

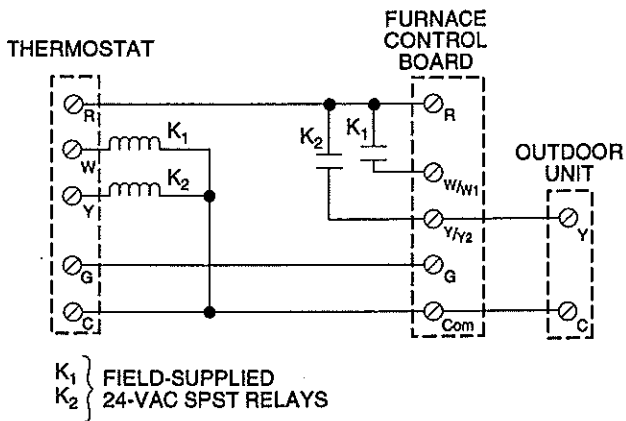

Fig. 2—Isolation of W/W1 and Y/Y2
Thermostat Circuits

A95097

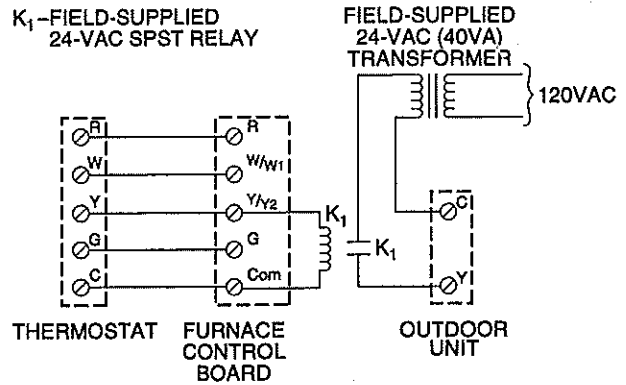
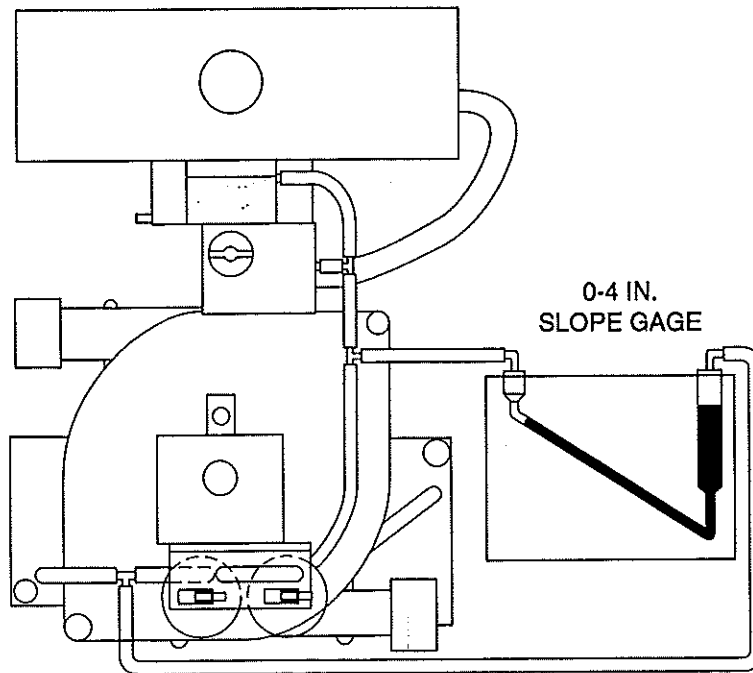

Fig. 3—Isolation of Outdoor Unit with a Separate
24-v Supply

A95098

Appendix C

Pressure Check Diagram



A95050

UNIT SIZE (BTUH)	HIGH-PRESSURE SWITCH		LOW-PRESSURE SWITCH	
	Make Point	Break Point	Make Point	Break Point
40,000	1.81 in. wc max	1.63 in. wc \pm 0.05	0.75 in. wc max	0.60 in. wc \pm 0.05
60,000	1.81 in. wc max	1.63 in. wc \pm 0.05	0.95 in. wc max	0.80 in. wc \pm 0.05
80,000				
100,000				

Appendix D

Quick Motor Test Procedure

In an effort to provide a method of troubleshooting inducer and blower motor by themselves, the following procedure may save you some time in the event any of the following fault codes are the reason for service call (12, 32, 41, 42, or 44). If you get any other fault code, you should use main troubleshooting guide to isolate problem.

STEP		YES	NO	GO TO
1.	Turn power off, remove blower access panel, and disconnect R thermostat lead.	—	—	2
2.	Turn power on and depress door switch. Use a piece of tape to hold switch closed.	—	—	3
3.	Put setup switch SW-6 for COMPONENT TEST in ON position.	—	—	4
4.	After COMPONENT TEST is completed, does Fault Code 11 flash?	5	8	—
5.	Turn power off, put setup switch SW-6 for COMPONENT TEST in OFF position, and reconnect R thermostat lead to furnace control board.	—	—	6
6.	Replace blower access panel and turn power on. Wait a few sec, then reset thermostat. Observe operation of furnace through 1 heating cycle.	—	—	7
7.	Go to page number indicated in Index for START HERE section.	—	—	INDEX
8.	Does Fault Code 42 flash?	9	27	—
9.	Does inducer motor MTR1 turn on and come up to speed?	24	10	—
10.	Does inducer wheel rub against inducer housing?	16	11	—
11.	Does inducer wheel turn freely?	12	19	—
12.	Do you have 120v between I1 and I2 on furnace control board?	13	16	—
13.	Do you have 120v between terminals PL7-6 and PL7-12?	15	14	—
14.	You have an open wire or bad terminal on either the BLACK or WHITE wire between furnace control board and inducer motor MTR1.	—	—	16
15.	Are all pins and wire leads intact on connectors between furnace control board and inducer motor?	18	16	—
16.	Fix problem.	—	—	17
17.	Go to page number indicated in Index for CLEANUP AND START-UP INSTRUCTIONS.	—	—	INDEX
18.	Check Inducer PW line. To do this, connect a DC voltmeter across terminals PL7-2 BROWN (+) and PL7-10 YELLOW (-) on inducer motor. Repeat COMPONENT TEST by turning setup switch SW-6 OFF and then back ON. Does voltage across PL7-2 and PL7-10 change between states as shown below? <ul style="list-style-type: none"> • State 1—OFF (-0.1 — 0.1 vdc) • State 2—LOW (2.0 — 3.0 vdc) • State 3—HIGH (7.0 — 8.0 vdc) 	19	20	—
19.	Replace inducer motor or inducer motor assembly. Inspect electronics portion of failed motor for water damage. If present, find source of water and fix. Check A-coil and/or humidifier.	—	—	17
20.	Disconnect PL7 from inducer motor and connect a DC voltmeter across terminals PL7-2 BROWN (+) and PL7-10 YELLOW (-). Repeat COMPONENT TEST by turning setup switch SW-6 OFF and then back ON. Does voltage across PL7-2 and PL7-10 change between states as shown below? <ul style="list-style-type: none"> • State 1—OFF (-0.1 — 0.1 vdc) • State 2—LOW (6.0 — 7.0 vdc) • State 3—HIGH (10.5 — 11.5 vdc) 	19	21	—
21.	Connect a DC voltmeter across terminals PL1-6 BROWN (+) and PL1-4 YELLOW (-) on furnace control board. Repeat COMPONENT TEST by turning setup switch SW-6 OFF and then back ON. Does voltage across PL1-6 and PL1-4 change between states as shown below? <ul style="list-style-type: none"> • State 1—OFF (-0.1 — 0.1 vdc) • State 2—LOW (6.0 — 7.0 vdc) • State 3—HIGH (10.5 — 11.5 vdc) 	23	22	—
22.	Replace furnace control board.	—	—	17
23.	You have an open wire or bad terminal on either the BROWN or YELLOW wire between connectors PL1 and PL7. Repair it or replace main harness.	—	—	17
24.	Check RPM feedback line. To do this, connect a DC voltmeter across terminals PL7-2 BROWN (+) and PL7-1 ORANGE (-) on inducer motor. Repeat COMPONENT TEST by turning setup switch SW-6 OFF and then back ON. Does voltage across BROWN and ORANGE wires change between states as shown below? <ul style="list-style-type: none"> • State 1—OFF (11.5 — 12.5 vdc) • State 2—LOW (10.2 — 11.2 vdc) • State 3—HIGH (8.4 — 9.4 vdc) 	25	19	—

STEP		YES	NO	GO TO
25.	Connect a DC voltmeter across terminals PL1-6 BROWN (+) and PL1-5 ORANGE (-) on furnace control board. Repeat COMPONENT TEST by turning setup switch SW-6 OFF and then back ON. Does voltage across BROWN and ORANGE wires change between states as shown below? <ul style="list-style-type: none"> • State 1—OFF (11.5 — 12.5 vdc) • State 2—LOW (10.2 — 11.2 vdc) • State 3—HIGH (8.4 — 9.4 vdc) 	22	26	—
26.	You have an open wire or bad terminal on ORANGE wire between connectors PL1 and PL7. Repair it or replace main harness.	—	—	17
27.	Does Fault Code 41 flash?	28	7	—
28.	Does blower motor MTR2 turn on and come up to speed?	48	29	—
29.	Remove tape from door switch and turn power off at main disconnect.	—	—	30
30.	Does blower wheel rub against blower housing?	16	31	—
31.	Does blower wheel turn freely?	32	33	—
32.	Is blower wheel firmly mounted on motor shaft?	34	16	—
33.	Replace blower motor. Inspect electronics portion of failed motor for water damage. If present, find source of water and fix. Check A-coil and/or humidifier.	—	—	17
34.	Put setup switch SW-6 for COMPONENT TEST in OFF position.	—	—	35
35.	Turn power on and depress door switch. Use a piece of tape to hold switch closed. Wait a few sec for self test before proceeding to next step.	—	—	36
36.	Do you have 120v between B1 and B2 on furnace control board?	37	16	—
37.	Do you have 120v between BLACK and WHITE power leads at blower motor MTR2?	39	38	—
38.	You have an open wire or bad terminal on either the BLACK or WHITE wire between furnace control board and blower motor MTR2. Repair it or replace blower harness(es).	—	—	17
39.	Check Blower ON/OFF line. To do this, connect a DC voltmeter across terminals PL3-1 RED (+) and PL3-5 BLUE (-), then put setup switch SW-6 for COMPONENT TEST in ON position. Does voltage across RED and BLUE wires change between states as shown below? <ul style="list-style-type: none"> • State 1—OFF (-0.1 — 0.1 vdc) • State 2—ON (9.0 — 10.0 vdc) 	42	40	—
40.	Disconnect PL3 from furnace control board and connect a DC voltmeter across terminals PL3-1 (+) and PL3-5 (-) on furnace control board. Repeat COMPONENT TEST by turning setup switch SW-6 OFF and then back ON. Does voltage across PL3-1 and PL3-5 change between states as shown below? <ul style="list-style-type: none"> • State 1—OFF (-0.1 — 0.1 vdc) • State 2—ON (11.0 — 12.0 vdc) 	33	22	—
41.	You have an open wire or bad terminal on either the RED or BLUE wire between connectors PL13 and PL3. Repair it or replace blower harness(es).	—	—	17
42.	Connect a DC voltmeter across RED (+) and BLUE (-) wires at connector PL13. Repeat COMPONENT TEST by turning setup switch SW-6 OFF and then back ON. Does voltage across RED and BLUE wires change between states as shown below? <ul style="list-style-type: none"> • State 1—OFF (-0.1 — 0.1 vdc) • State 2—ON (9.0 — 10.0 vdc) 	43	41	—
43.	Put setup switch SW-6 for COMPONENT TEST in OFF position.	—	—	44
44.	Check Blower PW line. To do this, connect a DC voltmeter across terminals PL3-1 RED (+) and PL3-4 YELLOW (-) on furnace control board, then put setup switch SW-6 for COMPONENT TEST in ON position. Does voltage across RED and YELLOW wires change between states as shown below? <ul style="list-style-type: none"> • State 1—OFF (-0.1 — 0.1 vdc) • State 2—LOW (2.5 — 3.0 vdc) • State 3—HIGH (7.0 — 7.5 vdc) 	46	45	—
45.	Disconnect PL3 from furnace control board and connect a DC voltmeter across terminals PL3-1 (+) and PL3-4 (-) on furnace control board. Repeat COMPONENT TEST by turning setup switch SW-6 OFF and then back ON. Does voltage across PL3-1 and PL3-4 change between states as shown below? <ul style="list-style-type: none"> • State 1—OFF (-0.1 — 0.1 vdc) • State 2—LOW (3.0 — 4.0 vdc) • State 3—HIGH (9.0 — 10.0 vdc) 	33	22	—
46.	Connect a DC voltmeter across RED (+) and YELLOW (-) wires at connector PL13. Repeat COMPONENT TEST by turning setup switch SW-6 OFF and then back ON. Does voltage across RED and YELLOW wires change between states as shown below? <ul style="list-style-type: none"> • State 1—OFF (-0.1 — 0.1 vdc) • State 2—LOW (2.5 — 3.0 vdc) • State 3—HIGH (7.0 — 7.5 vdc) 	33	47	—
47.	You have an open wire or bad terminal on either the RED or YELLOW wire between connectors PL13 and PL3. Repair it or replace blower harness(es).	—	—	17

STEP		YES	NO	GO TO
48.	Check RPM feedback line. To do this, connect a DC voltmeter across terminals PL3-2 ORANGE (+) and PL3-3 VIOLET (-). Repeat COMPONENT TEST by turning setup switch SW-6 OFF and then back ON. Does voltage across ORANGE and VIOLET wires change between states as shown below? <ul style="list-style-type: none"> • State 1—OFF (12.0 — 12.5 vdc) • State 2—LOW (10.7 — 11.7 vdc) • State 3—HIGH (9.7 — 10.7 vdc) 	22	49	—
49.	Connect a DC voltmeter across ORANGE (+) and VIOLET (-) wires at connector PL13. Repeat COMPONENT TEST by turning setup switch SW-6 OFF and then back ON. Does voltage across ORANGE and VIOLET wires change between states as shown below? <ul style="list-style-type: none"> • State 1—OFF (12.0 — 12.5 vdc) • State 2—LOW (10.7 — 11.7 vdc) • State 3—HIGH (9.7 — 10.7 vdc) 	50	33	—
50.	You have an open wire or bad terminal on either the ORANGE or VIOLET wire between connectors PL13 and PL3. Repair it or replace blower harness(es).	—	—	17

Appendix E

Variable-Speed Condensing Furnace Duct Static and Blower Operation

This variable-speed furnace has an Integrated Control and Motor called an ICM. This ICM is controlled as stated in Sequence of Operation section. This furnace does a good job compensating for an improperly sized duct system, but this ICM is not a fix for all bad ductwork.

This troubleshooting guide has shown that the blower does a calibration 20 sec at start of any operation of ICM. Note that blower calibration sequence is different when setup switch SW-4 is turned ON for multi-zone operation. (See Sequence of Operation section.) These blower calibrations help to ensure proper airflow in heating and cooling. In heating mode, this calibration helps ensure proper temperature rise which prolongs life of heat exchanger. In cooling mode, this calibration helps ensure proper CFM per ton of cooling.

If furnace is on a call for heat or cooling and duct static is too high, ICM tries to overcome external static pressure. If duct static is excessive, ICM RPM will be out of range and a Fault Code 44 will flash on circuit board. The ICM RPM range is 250 to 1300 RPM as stated in Fault Code 44 troubleshooting section. To check for excessive static pressure, use the following Air Delivery Curves and Duct Static Check Sheet later in this Appendix.

EXAMPLE: Furnace is a 100,000 Btuh input with a 5 ton blower cooling capacity. We measured total external static pressure (ESP) to be 0.4 in. wc in low-heat operation.

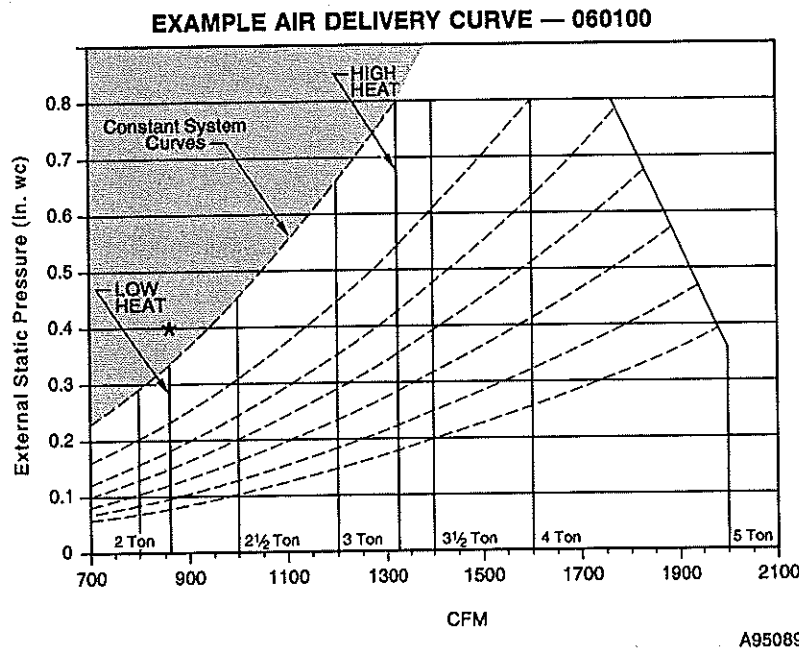

Use the dashed lines as guide lines. As you can see, the 0.4 in. wc total ESP is in the shaded area. The unit can deliver low heat, but as you follow the dashed guide lines, you see that they do not cross the high-heat line until it is off the chart, somewhere around 0.95 in. wc. The furnaces are rated at 0.5 in. wc total ESP and are tested to 0.8 in. wc total ESP.

See Static Pressure Reading Location Diagrams later in this Appendix for proper static reading locations. When checking total ESP, you must have blower operation without a Fault Code 44 occurring. If you have a Fault Code 44 in cooling and your setting is at 5 tons, set A/C tonnage to 4 tons and see if the Fault Code 44 goes away. If it does not, set switches to 3 tons, and so on until the Fault Code 44 goes away.

NOTE: When adjusting airflow, you must either turn power off or terminate thermostat call after every airflow adjustment. Record all static readings on Duct Static Check Sheet.

Solutions:

1. Dirty filter.
2. Plugged evaporator coil.
3. Re-size ductwork and/or layout.

SPECIAL NOTE: In zoning applications, it is recommended that when zone controls are applied, duct system be designed for sum of the peaks plus 25% oversize to allow furnace to operate within its design parameters. Contact your distributor for further details.

Air Delivery Curves

AIR DELIVERY CURVE — 042040

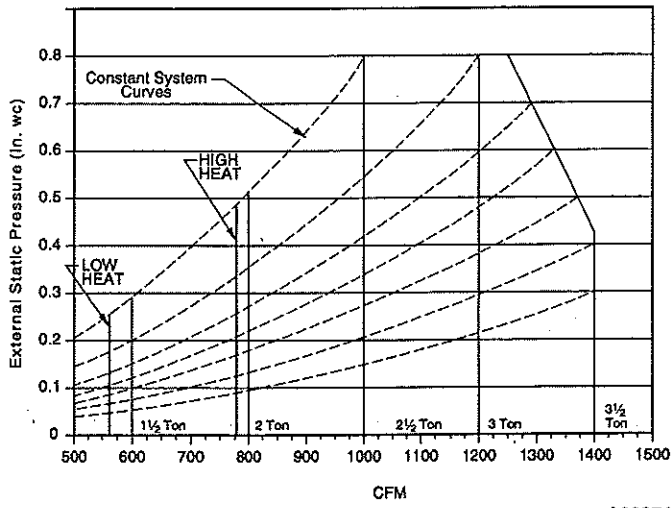

A93074

AIR DELIVERY CURVE — 042060

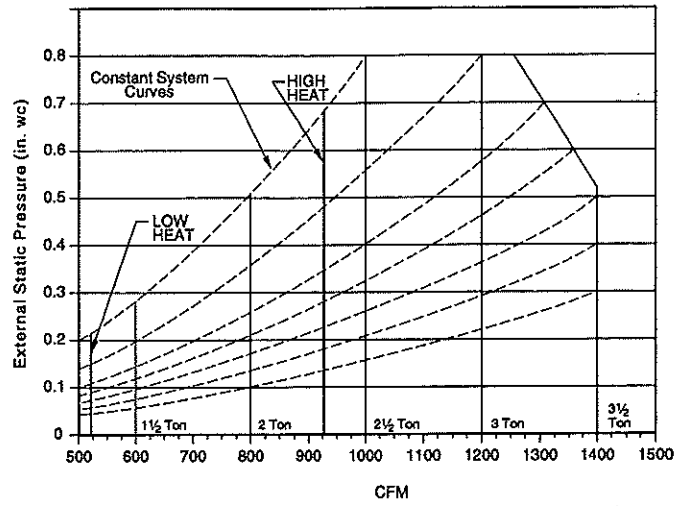

A93075

AIR DELIVERY CURVE — 042080

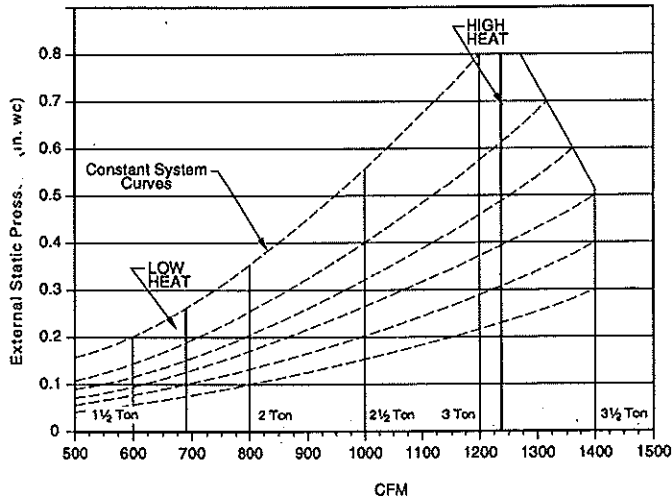

A93076

AIR DELIVERY CURVE — 060100

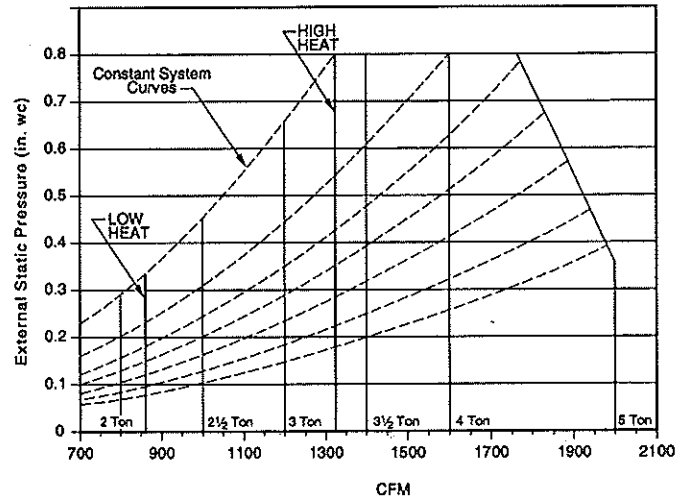

A93077

Static Pressure Reading Location Diagrams

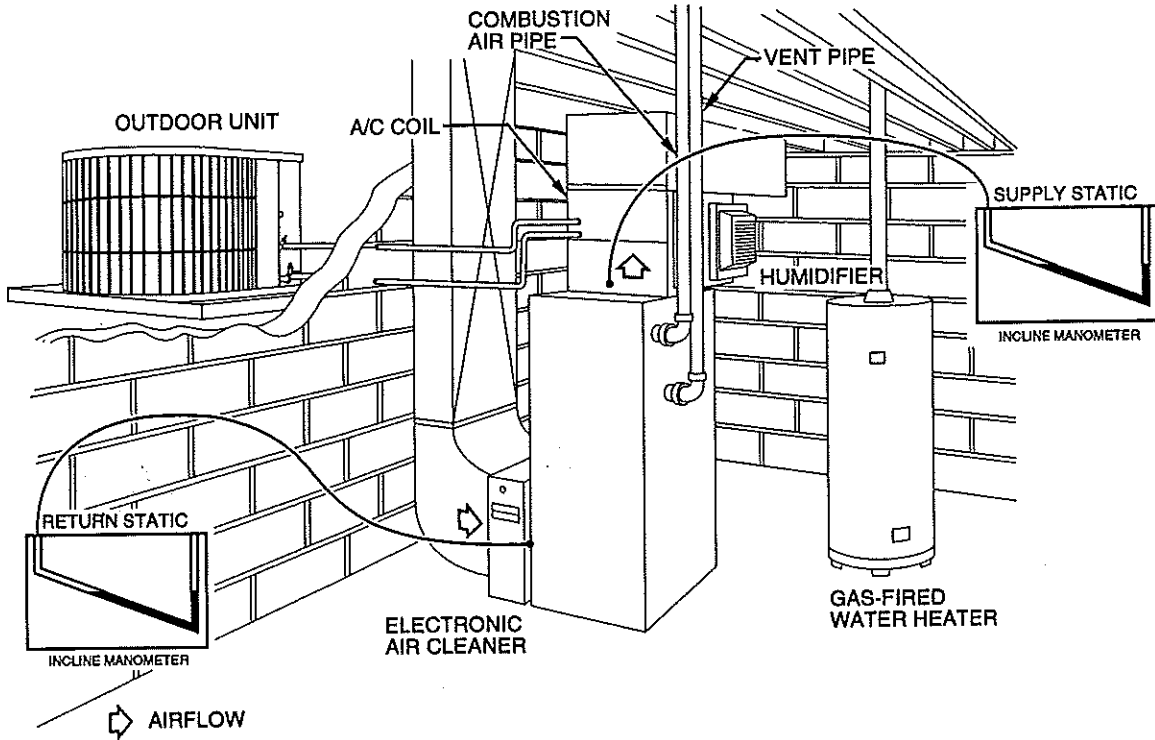

Basement — Upflow Application
Upflow Total Static Pressure Reading Locations

A95090

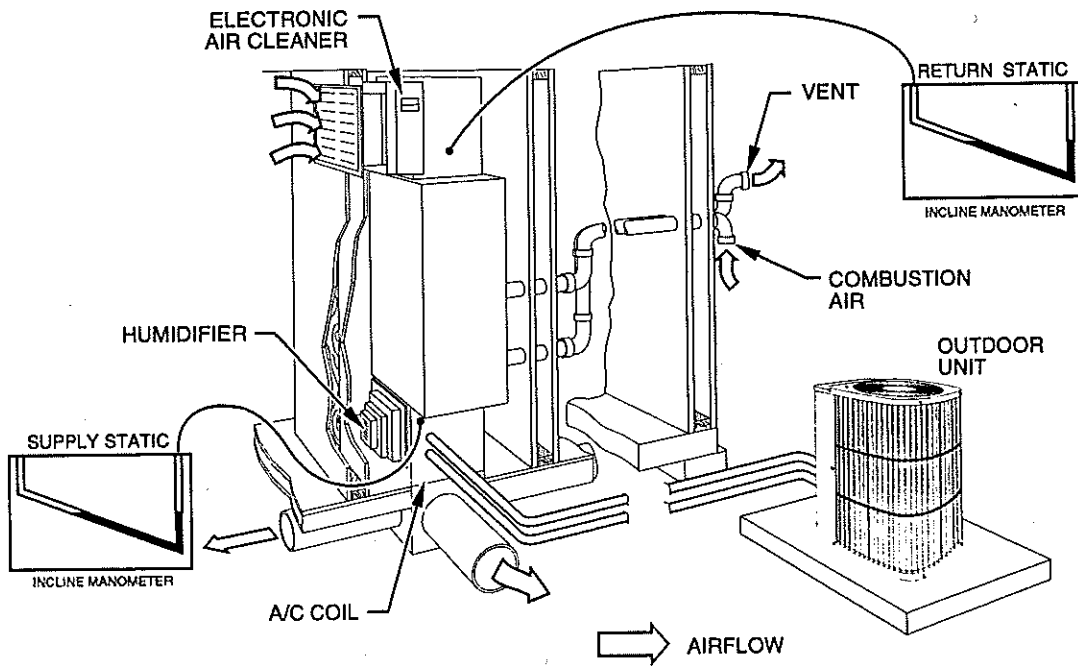

Closet — Downflow Application
Downflow Total Static Pressure Reading Locations

A95091

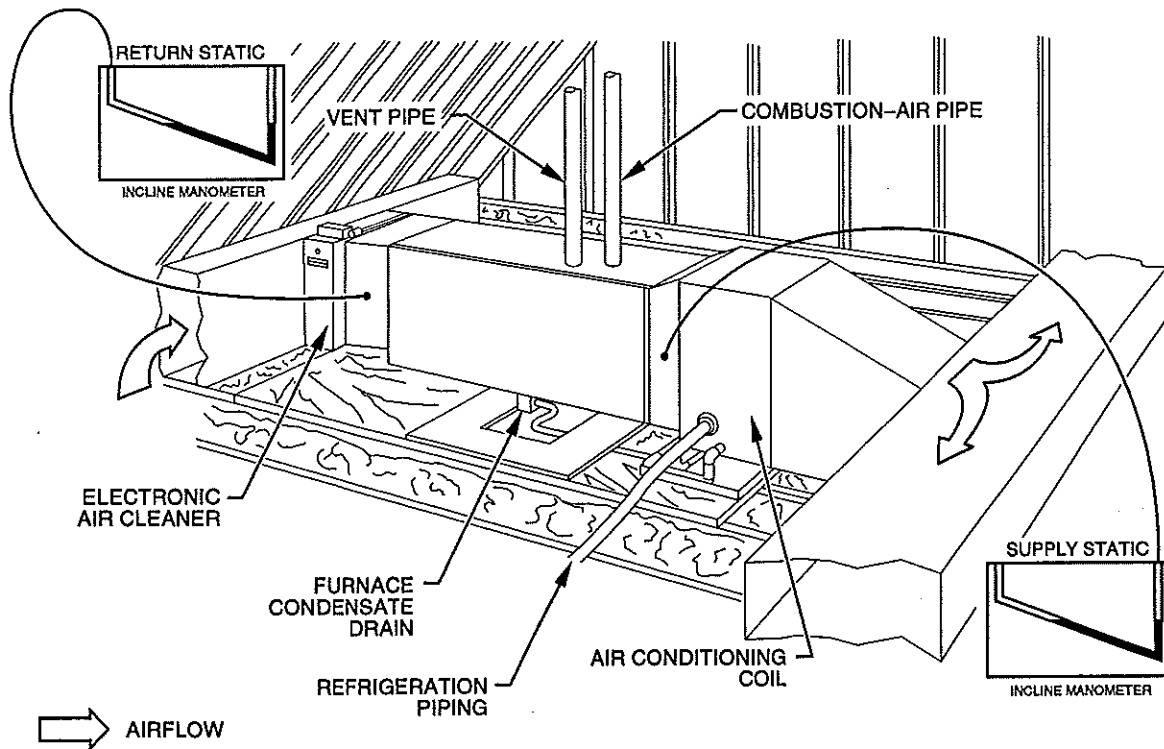

Attic — Horizontal Application

A95092

Horizontal Right and Left Airflow Total Static Pressure Reading Locations

Tools Needed:

- 1) Pitot Tube
- 1) Incline Manometer/Magnahelic

EXAMPLE 1

Return ESP after filter	0.40 in. wc
Supply ESP before coil	0.55 in. wc
Total ESP	0.95 in. wc

EXAMPLE 2

Return ESP before filter	0.15 in. wc
Filter Static Drop @ 2000 CFM	0.25 in. wc
Supply ESP after coil	0.30 in. wc
Coil Static Drop Wet	0.25 in. wc
Total ESP	0.95 in. wc

Both examples are correct. Example 1 ESP readings were taken as laid out in Static Pressure Reading Location Diagrams. Example 2 readings are taken as described. The coil and filter static pressure drops were taken from the manufacturer's Product Data Sheets with the assumption that we are trying to deliver 2000 CFM (this will vary).

NOTE: By plotting total ESP of 0.95 in. wc on the air delivery curve of a 100,000 Btuh input furnace, a Fault Code 44 would flash. (See Example Air Delivery Curve.)

Duct Static Check Sheet

Furnace:

Model Number _____

Serial Number _____

Position? U/F D/F H/R H/L

Indoor Coil:

Model Number _____

Serial Number _____

Outdoor Unit:

Model Number _____

Serial Number _____

Thermostat _____

Electronic Air Cleaner _____

What type of media filter is being used? _____

What is static pressure drop across filter? _____ At what CFM? _____

Does fault code go away when you remove filter? _____

What Zone System is applied? _____

What Zone has highest total ESP? _____

Is a Zone Bypass Damper being used? _____ and is it operating (opening) _____

What type of Bypass Humidifier is being used? _____

Is Bypass Humidifier setup switch on or off? _____

If you have a Fault Code 41 and/or 44, do the following:

1. Turn power off to furnace and outdoor unit.
2. Set A/C setup switch for 2 tons (800 CFM).
3. Turn only power to furnace back on.
4. Set thermostat for a call for cooling.
5. Check supply and return ESP as in Appendix E. Add these 2 ESP readings together for Total ESP. Repeat these steps until a fault code flashes on the microprocessor. Log your information on this sheet.

• At Low Heat:

Supply ESP _____ (Before or After Evaporator Coil) _____

Return ESP _____ (Before or After Filter) _____

Any Fault Code Flashing? If so what number? _____

• At High Heat:

Supply ESP _____ (Before or After Evaporator Coil) _____

Return ESP _____ (Before or After Filter) _____

Any Fault Code Flashing? If so what number? _____

• At 2 Ton A/C Setting:

Supply ESP _____ (Before or After Evaporator Coil) _____

Return ESP _____ (Before or After Filter) _____

Any Fault Code Flashing? If so what number? _____

• At 2.5 Ton A/C Setting:

Supply ESP _____ (Before or After Evaporator Coil) _____

Return ESP _____ (Before or After Filter) _____

Any Fault Code Flashing? If so what number? _____

• At 3 Ton A/C Setting:

Supply ESP _____ (Before or After Evaporator Coil) _____

Return ESP _____ (Before or After Filter) _____

Any Fault Code Flashing? If so what number? _____

• At 3.5 Ton A/C Setting:

Supply ESP _____ (Before or After Evaporator Coil) _____

Return ESP _____ (Before or After Filter) _____

Any Fault Code Flashing? If so what number? _____

• At 4 Ton A/C Setting:

Supply ESP _____ (Before or After Evaporator Coil) _____

Return ESP _____ (Before or After Filter) _____

Any Fault Code Flashing? If so what number? _____

• At 5 Ton A/C Setting:

Supply ESP _____ (Before or After Evaporator Coil) _____

Return ESP _____ (Before or After Filter) _____

Any Fault Code Flashing? If so what number? _____

Appendix F

Quick Reference Information

PRESSURE SWITCH MAKE/BREAK POINTS

UNIT SIZE (BTUH)	HIGH-PRESSURE SWITCH		LOW-PRESSURE SWITCH	
	Make Point	Break Point	Make Point	Break Point
40,000	1.81 in. wc max	1.63 in. wc \pm 0.05	0.75 in. wc max	0.60 in. wc \pm 0.05
60,000 80,000 100,000	1.81 in. wc max	1.63 in. wc \pm 0.05	0.95 in. wc max	0.80 in. wc \pm 0.05

FLAME SENSOR MICORAMPERAGE

- Microamp Range: 0.5 to 6.0 microamps
- Typical Reading: 4 to 6 microamps

HOT SURFACE IGNITOR OHM READING

- Ohm reading of HSI unused: 45 to 90 ohms (resistance will go up over time)

GAS VALVE OHM READINGS

- M to C: 98 ohms (solenoid coil)
- Hi to C: 1.5 ohm Bridge Rectifier (Use diode test function setting on ohm meter.)

POWER CHOKE

- When you put unit into component test function, measure motor amp draw before power choke. Then repeat component test, but this time measure amp draw without power choke in line. The amp draw should be higher without power choke. Some ammeters will register a lower amp draw (look for a change in amperage).

SPECIAL NOTE: ALL VOLTMETERS ARE NOT THE SAME, YOUR VOLTAGE READINGS WILL VARY. THIS APPLIES TO THE ENTIRE CONTENT OF THIS TROUBLESHOOTING MANUAL.

Appendix G

Thermostat Staging Algorithm

- Unit Default: Algorithm is initiated with Low Heat for 16 minutes. If call for heat still exists, unit transfers into High Heat until thermostat is satisfied.
- Low Heat run time is calculated based on previous heating cycle.
- High Heat on time is not calculated. High Heat is energized 1 of 3 ways and runs until thermostat has been satisfied.
 1. After Low Heat has run for 16 minutes and call for heat is still present.
 2. When algorithm does its calculation of previous cycle and determines High Heat is necessary.
 3. After the amount of calculated Low Heat on time has elapsed and there is still a call for heat present.
- The following flowchart shows how the algorithm calculates low heat on times. To use calculations, the amount of time unit ran in Low Heat (LH) and High Heat (HH) during previous cycle must be known. The algorithm uses these values to decide which stage of heat should be initiated on next call for heat.
- Four examples also follow illustrating what the unit will do on a cold start, coming out of night setback, coming on in low fire, and coming on in high fire.

EXAMPLE 1:

Furnace ran for 16 minutes in Low Heat and 5 minutes in High Heat.

LH = 16

HH = 5

Calculate: $(228 \times 16) + (350 \times 5) = 5398$

$3648 < 5398 < 5600 \Rightarrow$ therefore calculate next cycle Low Heat run time.

$LH_{run\ time} = \frac{5600 - 5398}{122} = 1.6 \Rightarrow$ therefore during next cycle, unit will run for 2 minutes in Low Heat and then switch to High Heat if a call for heat is still present.

EXAMPLE 2:

Furnace ran for 16 minutes in Low Heat and 10 minutes in High Heat.

LH = 16

HH = 10

Calculate: $(228 \times 16) + (350 \times 10) = 7148$

$7148 > 5600 \Rightarrow$ therefore next cycle will be initiated in High Heat. Low Heat run time is 0 minutes.

EXAMPLE 3:

Furnace ran for 13 minutes in Low Heat (LH) and 5 minutes in High Heat (HH). This will happen if control algorithm calculated maximum Low Heat run time be 13 minutes based on a previous cycle.

LH = 13

HH = 5

Calculate: $(228 \times 13) + (350 \times 5) = 4714$

$3648 < 4714 < 5600 \Rightarrow$ therefore calculate the next cycle Low Heat run time.

$LH_{run\ time} = \frac{5600 - 4714}{122} = 7.26 \Rightarrow$ therefore unit will run for 7 minutes in Low Heat and then switch to High Heat if a call for heat is still present.

EXAMPLE 4:

Furnace ran for 0 minutes in Low Heat and 10 minutes in High Heat.

LH = 0

HH = 10

Calculate: $(228 \times 0) + (350 \times 10) = 3500$

$3500 < 3648 \Rightarrow$ therefore next cycle will be initiated in Low Heat up to 16 minutes maximum, then switch to High Heat if a call for heat is still present.

VARIABLE SPEED CONDENSING FURNACE ALGORITHM

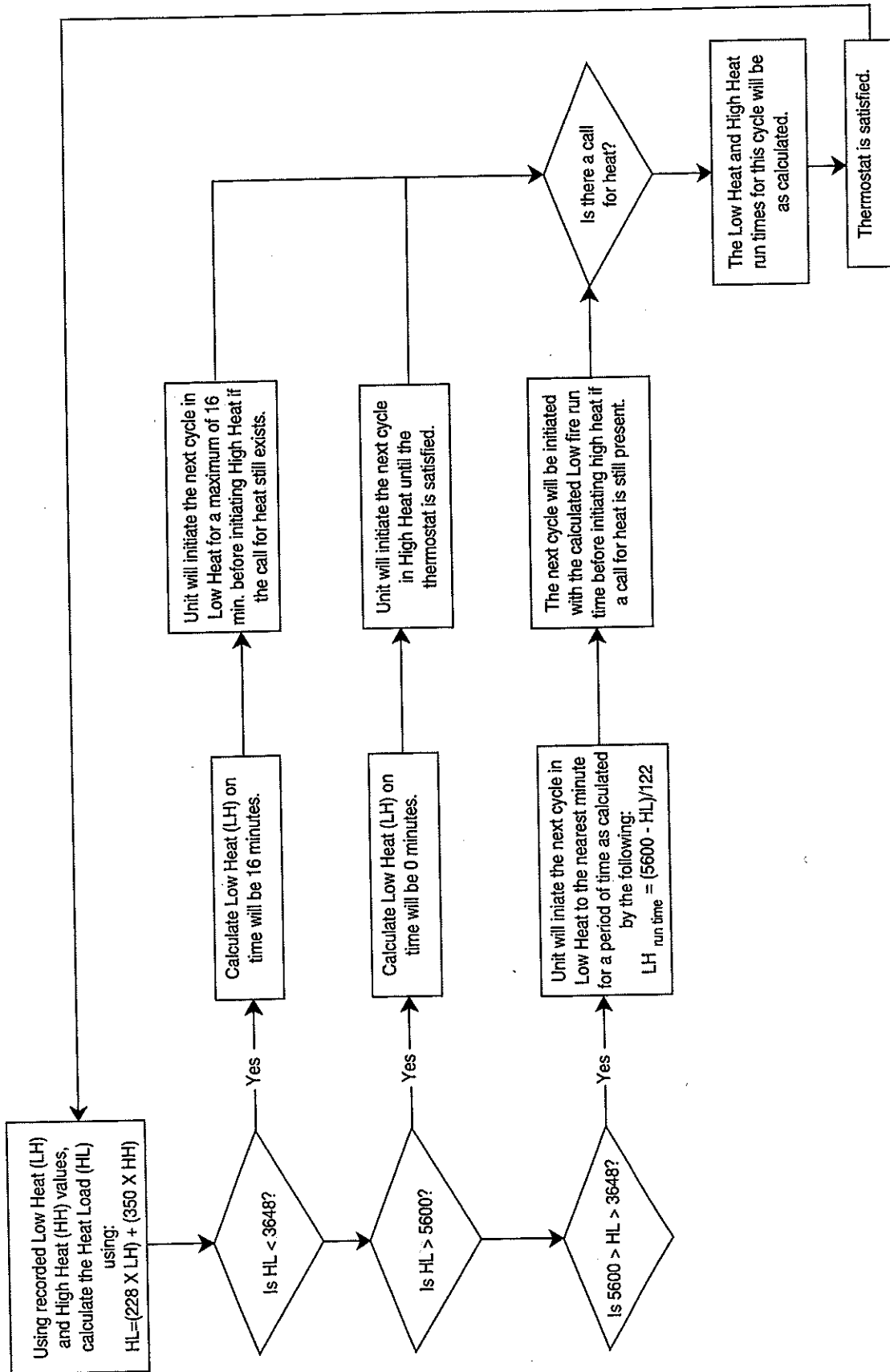

FEBRUARY 1995

A95094

SERVICE TRAINING

Packaged Service Training programs are an excellent way to increase your knowledge of the equipment discussed in this manual, including:

- Unit Familiarization
- Maintenance
- Installation Overview
- Operating Sequence

A large selection of product, theory, and skills programs is available, using popular video-based formats and materials. All include video and/or slides, plus companion book.

Classroom Service Training plus "hands-on" the products in our labs can mean increased confidence that really pays dividends in faster troubleshooting, fewer callbacks. Course descriptions and schedules are in our catalog.

CALL FOR FREE CATALOG 1-800-962-9212

Packaged Service Training

Classroom Service Training

A94328