

BDP / CARRIER 90 PLUS MULTIPOISE

UPFLOW / DOWNFLOW / HORIZONTAL RIGHT / HORIZONTAL LEFT

MODEL NUMBER:	340 MAV - 350 MAV / 58 MCA - 58 MXA
BTU SIZES:	40,000 / 60,000 / 80,000 / 100,000 / 120,000 btu's

ACCESSIBILITY CLEARANCE

30" front of furnaces.

CLEARANCE FROM COMBUSTIBLE MATERIAL

Upflow furnace only: For installation on combustible flooring.

Downflow furnace only: For installation on non-combustible floors only. For installation on combustible floors only when installed on special base No. KGASB0201ALL.

Horizontal position: Line contact is permissible only between lines formed by intersections of top and two sides of furnace jacket, and building joists, studs, framing. This furnace is for use with schedule-40 PVC, PVC-DWV, or ABS-DWV pipe, and must not be vented in common with other gas-fired appliances.

MINIMUM CLEARANCES TO COMBUSTIBLE MATERIAL

<u>TOP</u>	<u>SIDES</u>	<u>BACK</u>	<u>FRONT</u>	<u>VENT</u>	
1"	0"	0"	3"	0" UPFLOW
1"	0"	0"	3"	0" DOWNFLOW
1"	1"	0"	3"	0" HORIZONTAL

COLD AIR RETURN AIR DUCTS

Standard rules for cold air return ducts.

GARAGE

When furnace is installed in a residential garage, it must be installed so that burners and ignition furnace must be located or protected to avoid physical damage by vehicles.

GENERAL

CAUTION: Local codes may require a drain pan under entire furnace and condensate trap when a condensing furnace is used in attic applications.

WARNING: Do not install furnace on its back. Safety control operation will be adversely affected. Never connect return-air ducts to back of furnace. Failure to follow this warning could result in fire, personal injury or death.

The entire length of furnace must be supported when furnace used in horizontal position to insure proper draining.

HIGH ALTITUDE INSTALLATIONS

Deration	See BDP deration charts - Furnace can never be fired greater than input at sea level.
Orifice	See BDP deration charts.
Regulator Pressure	See BDP deration charts.
Pressure Switch	

MOBILE HOME

The Plus 90 single stage, hot surface ignition furnace is the only furnace approved for mobile home use. Then, only when the mobile home conversion kit is used. This kit will contain a new gas valve, orifices and stickers denoting that it has been converted.

VENTING MATERIAL AND REQUIREMENTS

Vent Pipe and Fittings	Combustion air and vent pipe fittings must conform to American National Standards Institute (ANSI) standards and American Society for Testing and Materials (ASTM) standards D1785 (schedule-40 PVC), D2665 (PVC-DWV), D2241 (SDR-21 and SDR-26 PVC), D2661 (ABS-DWV), or F628 (schedule-40 ABS).
------------------------	---

VENT CLEARANCE FROM COMBUSTIBLE MATERIAL

VENTING PROCEDURE

NOTE: Combustion air and vent pipes are restricted to a minimum length of 5 feet. A 12-inch minimum horizontal pipe section is recommended with short (5 to 8 ft) vertical vent system. This recommendation is to reduce excessive condensate droplets from exiting the vent pipe.

Vertical vent installation may require two 45° elbows instead of one 90° elbow to minimize gurgling sound from excessive condensate draining in vent pipe.

continued...

VENTING PROCEDURE

COMBUSTION-AIR AND VENT PIPE TERMINATION CLEARANCES

	U.S.A.	CANADA
Above grade level or above anticipated snow depth	1	1*
Dryer vent	3	3
From plumbing vent stack	3	3
Gas appliance vent terminal	3	3
From any mechanical fresh air intake	1	6
For furnaces with an input capacity less than 100,000 btuh - from any non-mechanical air supply or combustion air opening	1	1
For furnaces with an input capacity greater than 100,000 btuh - from any non-mechanical air supply or combustion air opening	1	3
From service regulator vent, electric and gas meters, and relief equipment	4#	6@
Above grade when adjacent to public walkway	7	7

* 18" above roof surface in Canada

Horizontal distance

@ 36" to electric meter in Canada

Combustion air and vent pipes must terminate together in same atmosphere pressure zone, either through roof or sidewall (roof termination preferred), using 1 of 4 accessory termination kits.

MISCELLANEOUS INFORMATION/NOTES

CAUTION: If a flexible connector is required or allowed by authority having jurisdiction, black iron pipe shall be installed at gas valve and extend a minimum of 2 inches outside furnace casing.

NOTE: Proper polarity must be maintained for 115-v wiring. If polarity is incorrect, control center fault code indicator light will flash rapidly and furnace will NOT operate.

For all hose positions - see furnace door.

SEQUENCE OF OPERATION

CAUTION: Furnace control must be grounded for proper operation, or control will lockout. Control is grounded through green wire routed to gas valve and burner box screw.

Using schematic diagram, follow sequence of operation through different modes. This furnace has a new control system. Read and following wiring diagram carefully.

NOTE: If 115-v power supply to furnace or 24-v blower access panel switch to is interrupted during a call for heat, blower will operate for 90 seconds when power is restored before heating cycle is resumed.

1. HEATING MODE - When thermostat "calls for heat," R-W circuit closes. Furnace control performs a self-check, verifies pressure switch contacts are open and starts inducer motor.

- a. **Prepurge period** - As inducer motor comes up to speed, pressure switch contacts close to begin a 15-sec prepurge period.
- b. **Ignitor warm up** - At end of prepurge period, ignitor is energized for a 17-sec ignitor warm-up period.
- c. **Ignition sequence** - When ignitor warm-up period is completed, gas valve opens, permitting gas flow to burners where it is ignited. After 5 seconds, ignitor is de-energized and a 2 second flame-sensing period begins.

HUM terminal on control center is energized with gas valve.

- d. **Flame sensing** - When burner flame is sensed, control begins blower on delay period and continues holding gas valve open.

If burner flame is not sensed, control center will de-energize gas valve and ignition sequence is repeated.

NOTE: Ignition sequence will repeat three additional times before a lockout occurs. Lockout will automatically reset after three hours, or can be manually reset by turning 115-v off (not at thermostat) for three seconds minimum, then on again.

- e. **Blower on delay** - 60 seconds after burner flame is proven, blower motor is energized on heating speed. Simultaneously, electronic air leaner terminal (EAC-1) is energized.
- f. **Blower off delay** - When thermostat is satisfied, circuit between R-W is opened, de-energizing gas valve (stopping gas flow to burners) and humidifier. Blower motor and electronic air cleaner will remain energized 90, 135, 180, or 225 seconds (depending on blower off time selection). Furnace is factory shipped set for a 135-sec blower off delay.
- g. **Post purge** - Inducer motor will remain energized 15 seconds after burners are extinguished.

START-UP PROCEDURES

1. Adjusting tuning valve - before firing furnace, pressure drop through heat exchanger must be adjusted for maximum efficiency. Pressure drop adjustment is accomplished with tuning valve as follows:

CAUTION: Ensure that gas supply to furnace is turned OFF.

NOTE: Burner box cover must be in place to ensure proper pressure switch operation.

- a. Remove tubes from both sides of pressure switch.
- b. Install field-supplied plastic tee and short piece of tube to each tube removed as shown in Fig. 41.
- c. Attach short piece of field-supplied tube to pressure switch as shown. Note label on pressure switch for proper tube connections.
- d. Connect slope gage or digital manometer to tees as shown in Fig. 42.
- e. Jumper R to W on control center to start inducer motor. Motor will start immediately.

NOTE: If pressure switch normally open (N/O) contacts are closed within 30 seconds, or are opened longer than 30 seconds after being closed, STATUS LED will flash. Proceed with adjustment regardless of this flashing code.

- f. Adjust tuning valve (located on inducer housing vent connection) to obtain 1.83 ± 0.01 inch negative water column. Use a 2 inch minimum slope gage or digital manometer. Adjust tuning valve as follows:
 - 1) Rotate tuning valve counter-clockwise until pin hits stop.
 - 2) Rotate tuning valve clockwise one notch at a time with inducer motor operating and manometer attached until pressure switch opens or manometer is 1.83 ± 0.01 inch w.c.
 - 3) Rotate tuning valve counter-clockwise two notches.
- g. Disconnect R to W jumper and wait for inducer to stop. Motor will be turned off without any post-purge delays.
- h. Repeat steps e through g to ensure tuning valve is adjusted properly.

NOTE: If tuning valve is adjusted properly, hot surface ignitor will be energized approximately 15 seconds after pressure switch closes its N/O contacts.

- i. Remove R to W jumper.
- j. Disconnect slope gage, field-supplied plastic tees, and short pieces of tube.
- k. Connect furnace pressure tubes to pressure switch.

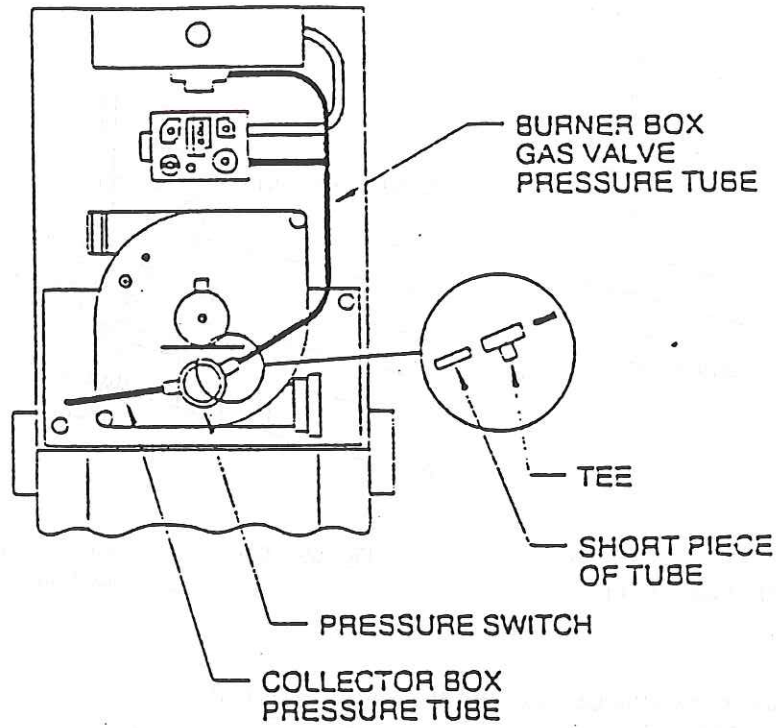

A93037

Fig. 41—Adjusting Tuning Valve – Pressure Tube Connections

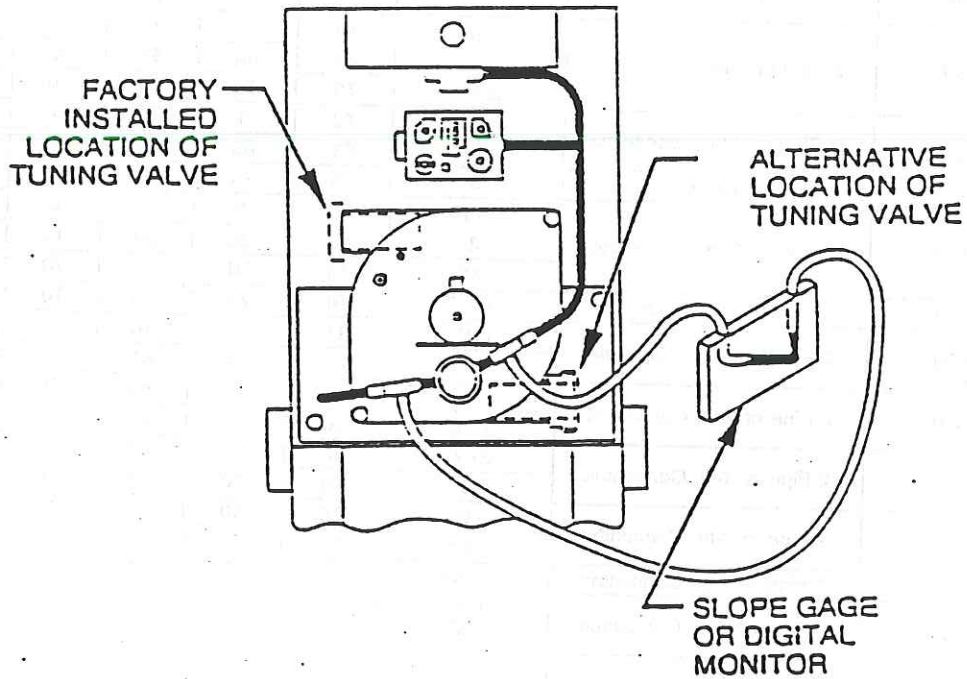

A93038

Fig. 42—Adjusting Tuning Valve – Slope Gage Attachment

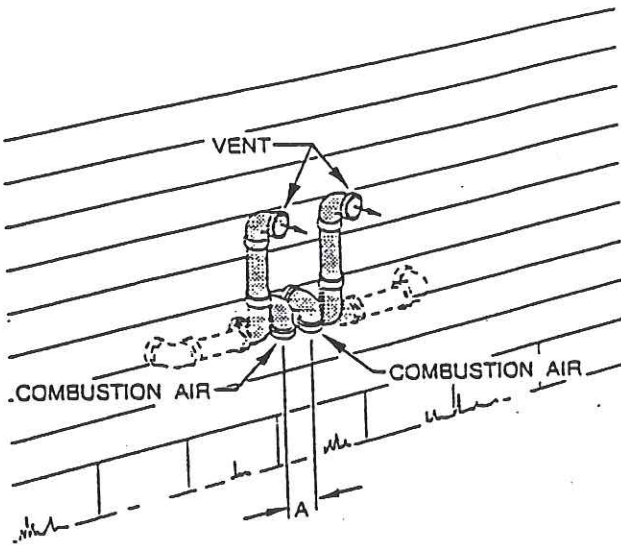

Fig. 38—Sidewall Termination (more than 12 in.)

A85183

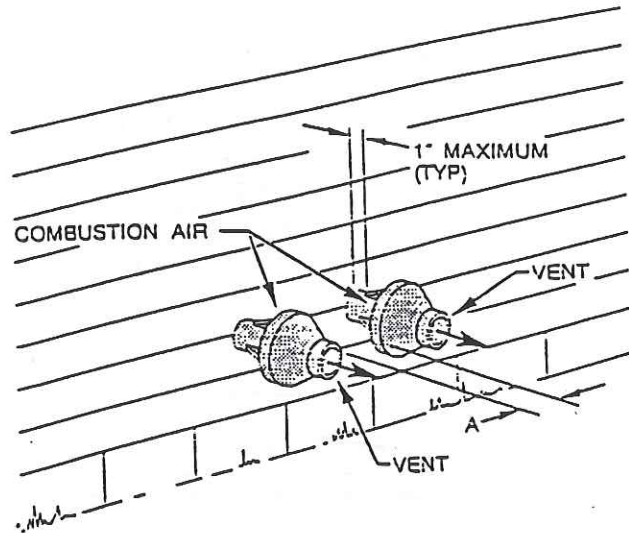

Fig. 39—Concentric Vent and Combustion Air Termination

A93057

TABLE 7—MAXIMUM ALLOWABLE PIPE LENGTH (FT)

ALTITUDE	UNIT SIZE	TERMINATION TYPE	PIPE DIAMETER (IN.)	NUMBER OF 90° ELBOWS					
				1	2	3	4	5	6
0 TO 2000	040	2 Pipe or 2-In. Concentric	1	5	5	0	0	0	0
			1-1/2	70	70	70	70	70	70
	060	2 Pipe or 2-In. Concentric	1-1/2	35	30	20	15	15	10
			2	70	70	70	70	70	70
	080	2 Pipe or 2-In. Concentric	1-1/2	10	5	0	0	0	0
			2	65	60	55	45	40	35
	100	2 Pipe or 2-In. Concentric	2	10	5	0	0	0	0
			2-1/2	65	60	50	45	35	25
	120	2 Pipe or 3-In. Concentric	2-1/2	10	5	5	0	0	0
			3	40	35	30	15	5	0
2001 to 3000	040	2 Pipe or 2-In. Concentric	1-1/2	70	70	70	70	66	61
			2	31	26	16	11	11	6
	060	2 Pipe or 2-In. Concentric	1-1/2	70	67	66	61	61	61
			2	58	53	48	39	34	29
	080	2 Pipe or 2-In. Concentric	2-1/2	70	70	70	70	70	70
			2-1/2	58	53	44	39	29	20
	100	2 Pipe or 3-In. Concentric	3	70	70	70	70	70	70
			3	35	30	25	11	2	0
	120	2 Pipe or 3-In. Concentric	3	63	62	62	61	61	61
			3"	70	70	70	70	70	70
3001 to 4000	040	2 Pipe or 2-In. Concentric	1-1/2	70	70	67	66	61	56
			1-1/2	29	24	15	10	9	0
	060	2 Pipe or 2-In. Concentric	2	68	63	62	57	57	56
			2	55	50	45	36	31	26
	080	2 Pipe or 2-In. Concentric	2-1/2	70	70	70	70	70	70
			2-1/2	55	50	41	36	26	17
	100	2 Pipe or 3-In. Concentric	3	70	70	70	70	70	70
			3	33	28	23	10	0	0
	120	2 Pipe or 3-In. Concentric	3	59	59	58	57	57	56
			3"	70	70	70	70	70	70

4001 to 5000†	040	2 Pipe or 2-In. Concentric	1-1/2	70	67	62	62	57	52
	060	2 Pipe or 2-In. Concentric	1-1/2	27	22	13	8	7	0
			2	64	59	58	53	52	52
	080	2 Pipe or 2-In. Concentric	2	52	47	42	33	28	23
			2-1/2	70	70	70	70	70	70
100	2 Pipe or 3-In. Concentric	2-1/2	52	47	38	33	24	15	
		3	70	70	70	70	70	70	
120	2 Pipe or 3-In. Concentric	3	31	26	21	8	0	0	
		3"	56	55	54	53	52	52	
5001 to 6000†	040	2 Pipe 2-In. Concentric	1-1/2	68	63	58	57	52	47
	060	2 Pipe or 2-In. Concentric	1-1/2	26	21	12	7	6	0
			2	60	55	54	49	48	47
	080	2 Pipe or 2-In. Concentric	2	49	44	39	30	25	20
			2-1/2	70	70	70	70	70	70
	100	2 Pipe or 3-In. Concentric	2-1/2	49	44	35	30	21	12
3			70	70	70	70	70	70	
120	2 Pipe or 3-In. Concentric	3	29	24	19	7	0	0	
		3†	53	52	50	49	48	47	
6001 to 7000†	040	2 Pipe or 2-In. Concentric	1-1/2	64	59	54	53	48	43
	060	2 Pipe or 2-In. Concentric	1-1/2	24	19	10	5	0	0
			2	57	52	50	45	44	43
	080	2 Pipe or 2-In. Concentric	2	46	41	36	27	22	17
			2-1/2	70	70	68	67	66	64
	100	2 Pipe or 3-In. Concentric	2-1/2	46	41	32	27	18	10
3			70	70	68	67	66	64	
120	2 Pipe or 3-In. Concentric	3	27	22	17	5	0	0	
		3"	49	48	47	45	44	43	
7001 to 8000†	040	2 Pipe or 2-In. Concentric	1-1/2	60	55	50	48	43	38
	060	2 Pipe or 2-In. Concentric	1-1/2	22	17	8	0	0	0
			2	53	48	46	41	40	38
	080	2 Pipe or 2-In. Concentric	2	42	37	32	24	19	14
			2-1/2	66	65	63	63	60	59
	100	2 Pipe or 3 In. Concentric	2-1/2	42	37	29	24	16	7
3			66	65	63	62	60	59	
120	2 Pipe or 3-In. Concentric	3	25	20	15	0	0	0	
		3"	46	44	43	41	40	38	
8001 to 9000†	040	2 Pipe or 2-In. Concentric	1-1/2	55	50	45	44	39	34
	060	2 Pipe or 2-In. Concentric	1-1/2	20	15	7	0	0	0
			2	49	44	42	37	35	34
	080	2 Pipe or 2-In. Concentric	2	39	34	29	21	16	11
			2-1/2	62	60	58	56	55	53
	100	2 Pipe or 3-In. Concentric	2-1/2	39	34	26	21	13	5
3			62	60	58	56	55	53	
120	2 Pipe or 3-In. Concentric	3	23	18	13	0	0	0	
		3"	43	41	39	37	35	34	
9001 to 10000†	040	2 Pipe or 2-In. Concentric	1-1/2	51	46	41	39	34	29
	060	2 Pipe or 2-In. Concentric	1-1/2	18	13	5	0	0	0
			2	48	40	38	33	31	29
	080	2 Pipe or 2-In. Concentric	2	36	31	26	18	13	8
			2-1/2	57	55	53	51	49	47
	100	2 Pipe or 3-In. Concentric	2-1/2	36	31	23	18	10	2
3			57	55	53	51	49	47	
120	2 Pipe or 3-In. Concentric	3	21	16	11	0	0	0	
		3"	39	37	35	33	31	29	

NOTES:

1. Do not use pipe size greater than those specified in table or incomplete combustion, flame disturbance, or flame sense lockout may occur.
2. Size both the combustion-air and vent pipe independently, then use the larger diameter for both pipes.
3. Assume two 45° elbows equal one 90° elbow. Long radius elbows are desirable and may be required in some cases.
4. Elbows and pipe sections within the furnace casing and at the vent termination should not be included in vent length or elbow count.
5. The minimum pipe length is 5 ft for all applications.
 Vide radius elbow.
 ent sizing for Canadian installations over 4500 ft (1370 m) above sea level are subject to acceptance by the local authorities having jurisdiction.

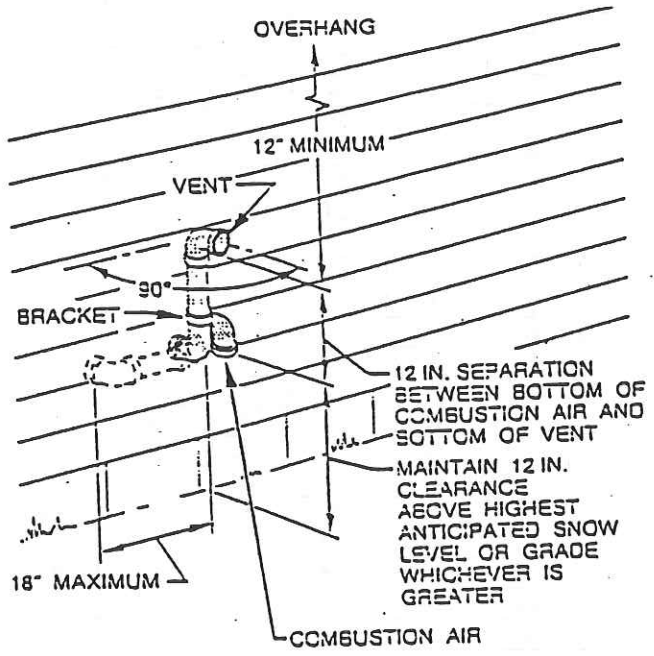

Fig. 32—Sidewall Termination (12 in. or more) A87225

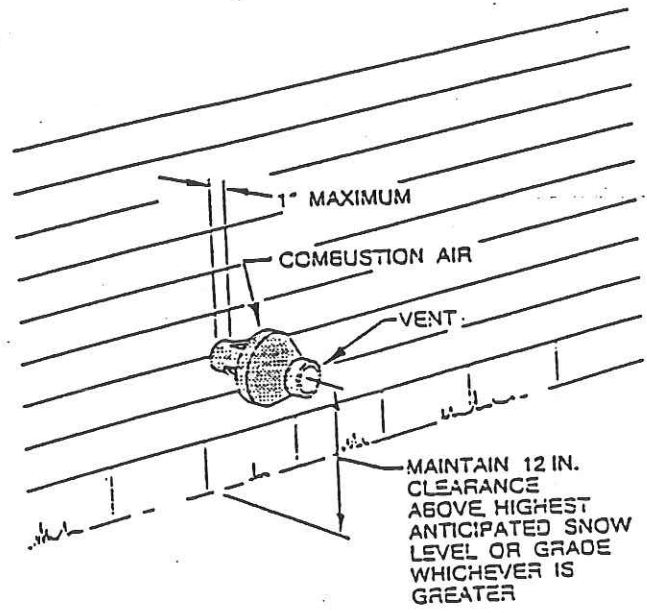

Fig. 34—Concentric Vent and Combustion-Air Side Termination A93055

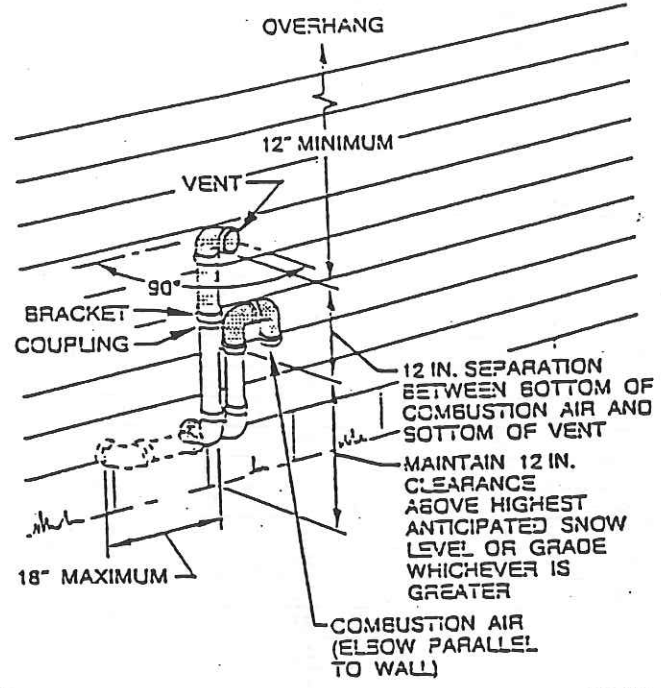
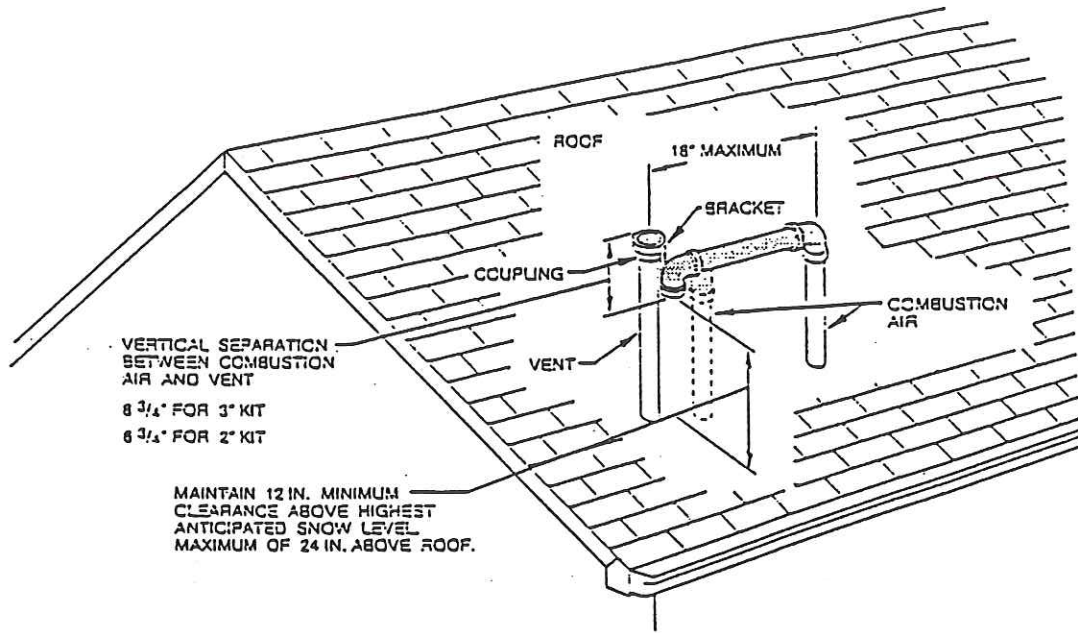
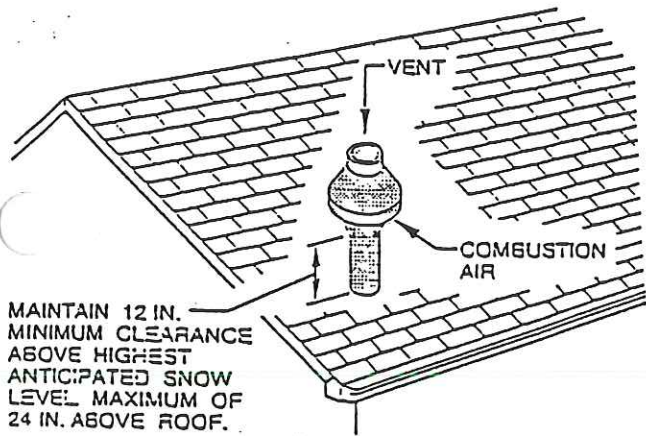

Fig. 33—Sidewall Termination (less than 12 in.) A87226



VERTICAL SEPARATION
BETWEEN COMBUSTION
AIR AND VENT
8 3/4" FOR 3" KIT
6 3/4" FOR 2" KIT

MAINTAIN 12 IN. MINIMUM
CLEARANCE ABOVE HIGHEST
ANTICIPATED SNOW LEVEL
MAXIMUM OF 24 IN. ABOVE ROOF.



MAINTAIN 12 IN.
MINIMUM CLEARANCE
ABOVE HIGHEST
ANTICIPATED SNOW
LEVEL MAXIMUM OF
24 IN. ABOVE ROOF.

A93054

Fig. 31—Concentric Vent and Combustion-Air Termination, Roof Termination (Preferred)

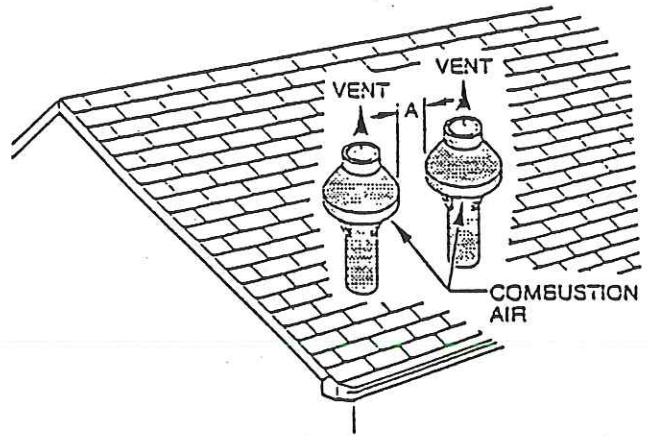

A93056

Fig. 36—Concentric Vent and Combustion-Air Roof Termination

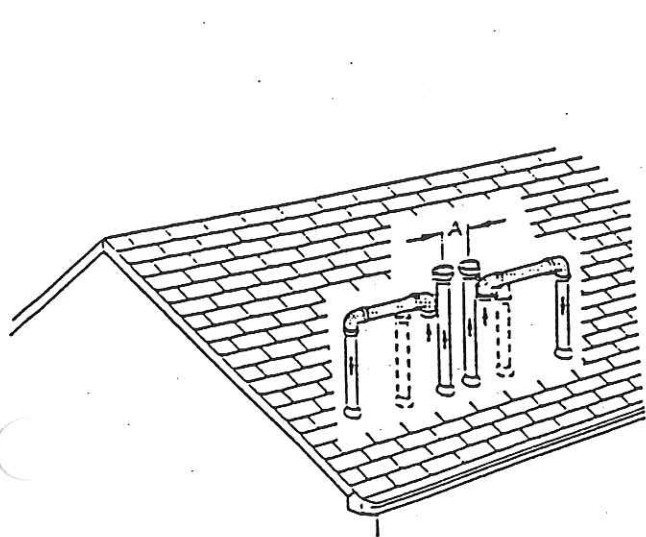

A85182

Fig. 35—Rooftop Termination

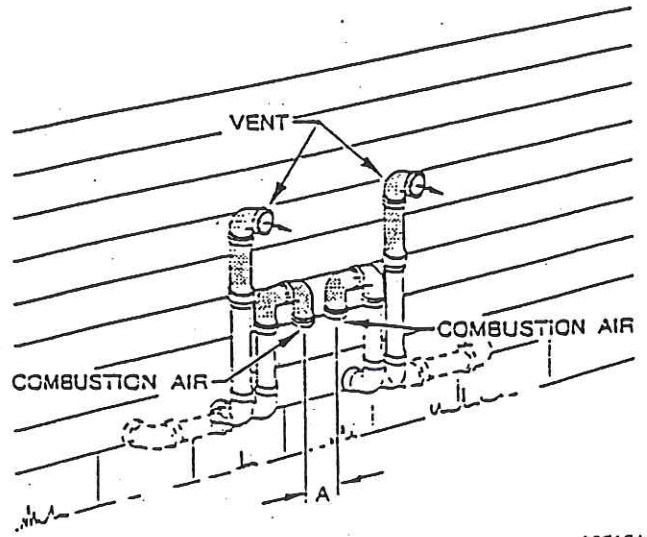

A85184

Fig. 37—Sidewall Termination (12 in. or less)

