

# BDP 90i

<b>MODEL NUMBER:</b>	355 MAV
<b>BTU SIZES:</b>	40 - 60 - 80 - 100 - 120,000 BTU's

### ACCESSIBILITY CLEARANCE

Minimum front clearance for service is 30".  
 Flue gas temperature 131°F (55°) vent pressure positive. Category IV.

### CLEARANCE FROM COMBUSTIBLE MATERIAL

#### MINIMUM CLEARANCE TO COMBUSTIBLE MATERIAL

	TOP	SIDES	BACK	FRONT	VENT
UPFLOW	1	0	0	3	0
DOWNFLOW	1	0	0	3	0
HORIZONTAL	1	1*	0	3	0

\* Clearance shown in for air inlet and air outlet end.

Upflow furnace only - for installation on combustible flooring. Downflow furnace only - for installation on non-combustible floors only. For installation on combustible floors only when installed on special base No. KGASB0201ALL.

Not to be installed on carpeting, tile, or any other combustible materials other than wood.

### COLD AIR RETURN AIR DUCTS

These furnaces are shipped in the UPFLOW orientation and can be used in UPFLOW, DOWNFLOW, HORIZONTAL RIGHT, or HORIZONTAL LEFT (supply airflow direction) applications with minor modifications.

Sealed to furnace casing.

Do not connect return air to back of furnace.

NOTE: These furnaces are designed for a minimum continuous return-air temperature of 60°F for intermittent operation down to 55°F such as when used with a night setback thermostat. Return-air temperature must not exceed a maximum of 85°F. Failure to follow these return-air temperature limits may affect reliability of heat exchanger, motors, or controls.

NOTE: Side return-air openings can ONLY be used in UPFLOW installed applications.

Bottom Closure Panel: MUST be in place when side return air is used.

GARAGE

Approved. Must meet requirements of UMC and the Good Practice Book.

When furnace is installed in a public garage, airplane hangar, or other building having a hazardous atmosphere, unit must be installed in accordance with requirements of National Fire Protection Association, Inc.

GENERAL

NOTE: For proper furnace operation, install furnace so that it is level or pitched forward within 1/2 in. to ensure proper condensate drainage from secondary heat exchangers.

CAUTION: If these furnaces are used during construction when adhesives, sealers, and/or new carpets are being installed, make sure all combustion and circulating air requirements are followed. If operation of furnace is required during construction, use clean outside air for combustion and ventilation. Compounds of chlorine and fluorine, when burned with combustion air, form acids which will cause corrosion of heat exchangers. Some of these compounds are found in paneling, dry wall adhesives, paints, thinners, masonry cleaning materials, and many other solvents commonly used in construction process.

WARNING: Do not install furnace on its back. Safety control operation will be adversely affected.

The 24 v circuit contains a 3-amp automotive-type fuse located on control center. Any electrical shorts of 24 v wiring during installation, service, or maintenance may cause fuse to blow. If fuse replacement is required, use only a fuse of identical size (3 amp).

This furnace must be installed so electrical components are protected from water.

CAUTION: Furnace control must be grounded for proper operation or control will lockout. Control is grounded through green wire routed to gas valve and burner box screw.

NOTE: Proper polarity must be maintained for 115 v wiring. If polarity is incorrect, control center fault code indicator light will flash rapidly and furnace will NOT operate.

HIGH ALTITUDE INSTALLATIONS

Deration	Standard deration 4% for every 1,000 feet of elevation above 2,000 feet of elevation.
Orifice	Factory orifices only - NO peening and redrilling
Regulator Pressure	High heat 3.5" w.c. ± .3" w.c. - low heat 1.5" w.c. for ± .2" w.c.
Pressure Switch	High heat/fire pressure switch - low heat/fire pressure switch. Normally open switches that close upon inducer operation only the low heat pressure switch closes on low heat. Both high level heat and low heat pressure switches are closed on high heat.

MOBILE HOME

Approved with manufacturer's mobile home kit only.

### VENTING MATERIAL AND REQUIREMENTS

Vent Pipe	D1785 (schedule-40 PVC), D2665 (PVC-DWC), D2241 (SDR-21 and SDR-26 PVC), D2661 (ABS-DWV), or F628 (schedule-40 ABS)
Vent Fittings	Standard fittings of schedule 40 PVC, PVC-DWV, or ABS-DWV.

### VENT CLEARANCE FROM COMBUSTIBLE MATERIAL

0" clearances from ABS  
0" clearances from PVC

### VENTING PROCEDURE

**DIRECT VENTING:** The 355MAV models require a dedicated (one 355MAV furnace only) direct-vent system.

**NOTE:** Furnace combustion-air and vent pipe connections are sized for 2-in pipe. Any size change should be made outside furnace casing in vertical pipe. This will allow proper drainage of vent condensate.

Refer to Table 6 - Combustion air and vent pipe termination clearances.

Combustion air and vent pipes must terminate together in same atmosphere pressure zone, either through roof or sidewall (roof termination preferred), using 1 of 4 accessory termination kits.

**CAUTION:** When vent pipe is exposed to temperature below freezing, such as when it passes through an unheated space or when a chimney is used as a raceway, pipe must be insulated as shown in Table 8 with Armaflex-type insulation.

Support combustion-air and vent piping a minimum of every 5 ft. (3 ft. for SDR-21 or -26 PVC) using perforated metal hanging strap.

Slope combustion-air and vent pipes toward furnace a minimum of 1/4 in. per linear ft with no sags between hangers.

#### COMBUSTION-AIR AND VENT PIPE DIAMETER:

1. Using Table 7, determine preliminary combustion-air pipe diameter.
2. Using Table 7, determine preliminary vent pipe diameter.
3. Use largest diameter pipe determined in (1) and (2) above for both pipes.

## MISCELLANEOUS INFORMATION/NOTES

**CAUTION:** Do not connect aluminum wire between disconnect switch and furnace. Use only copper wire.

Watch for sludge build up in condensate lines and trap. This problem will effect pressure switch operation.

Pay particular attention to the installation series numbers. Venting chart and other technical information changes periodically.

## VENTING PROCEDURE

### CONCENTRIC VENT AND COMBUSTION-AIR TERMINATION KIT INSTALLATION:

**NOTE:** If these instructions differ from those packaged with termination kit, follow kit instructions.

Combustion-air and vent pipes must terminate outside structure. A factory accessory termination kit must be installed in 1 of the installations shown in Fig. 30, 31, 22, 33, and 34. Four termination kits are available:

1. The 2-in termination bracket kit is for 1-in., 1 1/2 in., and 2-in. diameter 2-pipe termination systems.
2. The 3-in. termination bracket kit is for 2 1/2 in. and 3-in. diameter 2-pipe termination system.
3. The 2-in concentric vent/air termination kit is for 1-in., 1 1/2 in., 2-in., and 3-in diameter pipe systems when single penetration of wall or roof are desired.
4. The 3-in. concentric vent/air termination kit is for 2 1/2 in. and 3-in. diameter pipe systems when single penetration of wall or roof are desired.

**NOTE:** Shaded parts in Fig. 30, 31, 22, 33, and 34 are considered to be termination. These components should NOT be counted when determining pipe diameter.

**NOTE:** Roof termination is preferred since it is less susceptible to damage, has reduced changes to intake contaminants, and has less visible vent vapors. See Fig 30 or 31.

**NOTE:** Sidewall termination may require sealing or shielding of building surfaces with a corrosive resistance material due to corrosive combustion products of vent system.

### EXTENDED EXPOSED SIDEWALL PIPES:

Sidewall combustion-air and vent pipe terminations may be extended beyond area shown in Fig. 32 or 33 in outside ambients by insulating pipes as indicated in Table 8.

1. Determine combustion-air and vent pipe diameters as stated above, using total pipe length and number of elbows.
2. Using Winter Design Temperature (used in load calculations), find appropriate temperature for your application and furnace model.

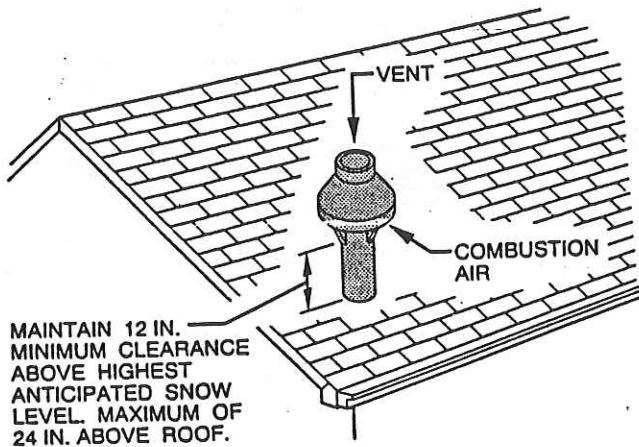

Fig 31. Concentric Vent and Combustion-Air Termination, Roof Termination (Preferred)

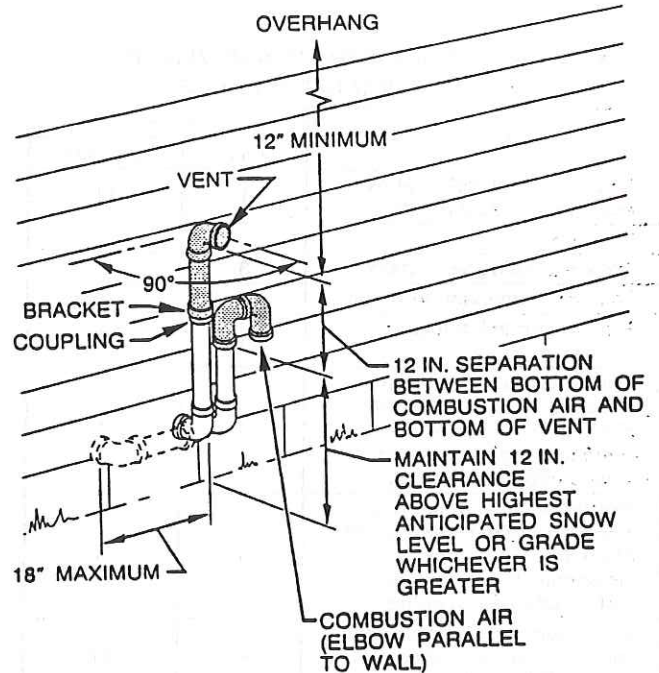

Fig 33 - Sidewall Termination (less than 12 in)

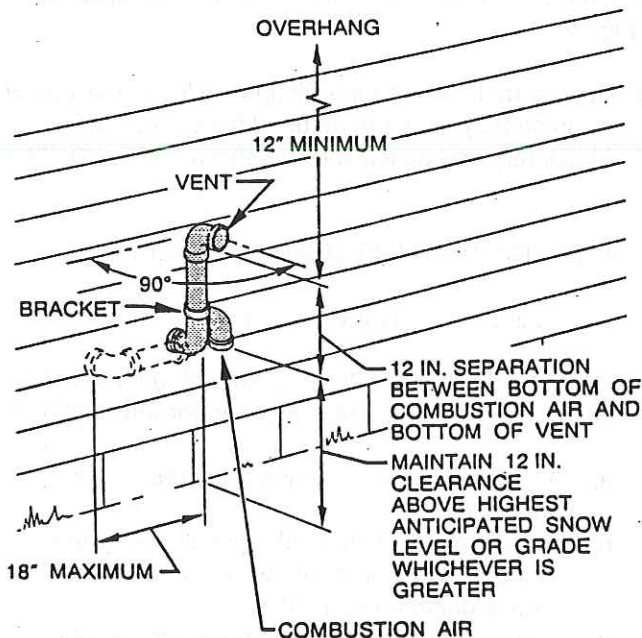

Fig 32. Sidewall Termination (12 in. or more)

3. Determine required insulation thickness for exposed pipe lengths.

NOTE: Pipe length (ft) specified for maximum pipe lengths located in unconditioned spaces cannot exceed total allowable pipe length as specified in Table 7. (page 9)

#### TWO-PIPE TERMINATION KIT

1. Determine location for termination:

Considerations for following should be used when determining an appropriate location for termination kit.

- a. Comply with all clearance requirements as stated in Table 6.
- b. Termination kit should be positioned where vent vapors will not damage plants/shrubs or air conditioning equipment.
- c. Termination kit should be positioned so that it will not be affected by wind eddy, or allow recirculation of flue gases, airborne leaves, or light snow.
- d. Termination kit should be positioned where it will not be damaged or subjected to foreign objects, such as stones, balls, etc.
- e. Termination kit should be positioned where vent vapors are not objectionable.

2. Cut 2 holes, 1 for each pipe, of appropriate size for pipe size being used.
3. Loosely install elbow in bracket and place assembly on combustion-air pipe.

**TABLE 6—COMBUSTION-AIR AND VENT PIPE TERMINATION CLEARANCES**

LOCATION	CLEARANCE (FT)	
	U.S.A.	CANADA
Above grade level or above anticipated snow depth	1	1‡
Dryer vent	3	3
From plumbing vent stack	3	3
Gas appliance vent terminal	3	3
From any mechanical fresh air intake	1	6
For furnaces with an input capacity less than 100,000 Btuh—from any non-mechanical air supply or combustion-air opening	1	1
For furnaces with an input capacity greater than 100,000 Btuh—from any non-mechanical air supply or combustion-air opening	1	3
From service regulator vent, electric and gas meters, and relief equipment	4*	6†
Above grade when adjacent to public walkway	7	7

If installing 2 adjacent 355MAV furnaces, refer to Multi-Venting and Vent Terminations of 355MAV furnaces for proper vent configurations.

\* Horizontal distance.

†36 in. to electric meter in Canada only.

‡18 in. above roof surface in Canada.

Table 6 - Combustion-air and vent pipe termination clearances

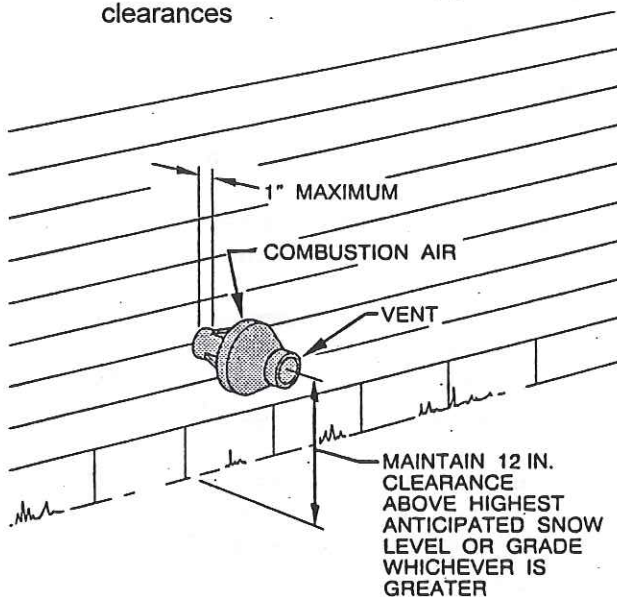

Fig 34 - Concentric Vent and Combustion-Air Side Termination

**ROOF TERMINATION:** Loosely install pipe coupling on properly cut vent pipe. Coupling must be positioned so bracket will mount as shown in Fig 30.

For applications using combustion-air pipe option, indicated by dashed lines in Fig. 30 install 90° street elbow into 90° elbow, making U-fitting. A 180° U-fitting may be used.

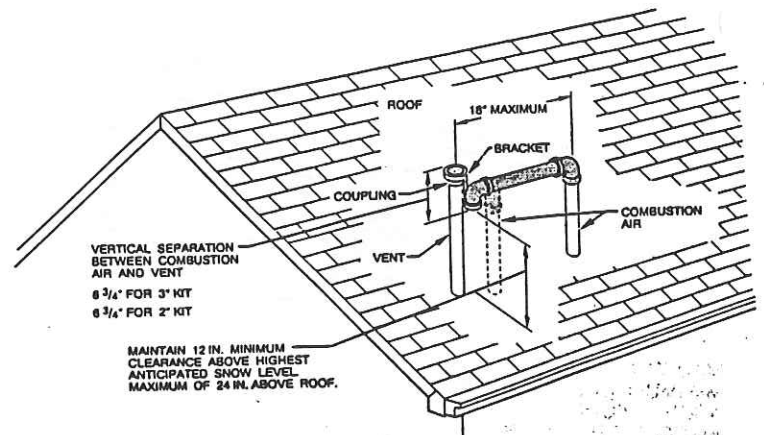

Figure 30 - Roof Termination (Preferred)

**SIDEWALL TERMINATIONS-** Install bracket as shown in Fig 32 or 33.

For applications using vent pipe option indicated by dashed lines in Fig 32, rotate vent elbow 90° from position shown in Fig 32.

4. Disassemble loose pipe fittings. Clean and cement using same procedure as used for system piping.
5. Check required dimensions as shown in Fig 30, 32, or 33.

**CONCENTRIC VENT/AIR TERMINATION KIT**

1. Determine location for termination.

Considerations for following should be used when determining an appropriate location for termination kit.

- a. Comply with all clearance requirements as stated in Table 6.
- b. Termination kit should be positioned where vent vapors will not damage plants/shrubs or air conditioning equipment.
- c. Termination kit should be positioned so it will not be affected by wind eddy, or that may allow recirculation of flue gases, airborne leaves, or light snow.
- d. Termination kit should be positioned where it will not be damaged or subjected to foreign objects such as stones, balls, etc.
- e. Termination kit should be positioned where vent

vapors are not objectionable.

2. Cut 1 hole. A 4-in diameter hole for 2-in kit, or a 5-in diameter hole for 3-in kit.
- Loosely assemble Concentric vent/air termination components together using instructions in kit.
4. Remove rain shield and slide assembled kit thru hole.

**NOTE:** Do not allow insulation or other materials to accumulate inside of pipe assembly when installing it through hole.

**ROOF TERMINATION:** Locate assembly through roof to appropriate height as shown in Fig.31.

**SIDEWALL TERMINATION:** Locate assembly through sidewall, with rain shield positioned no more than 1-in from wall as shown in Fig. 34.

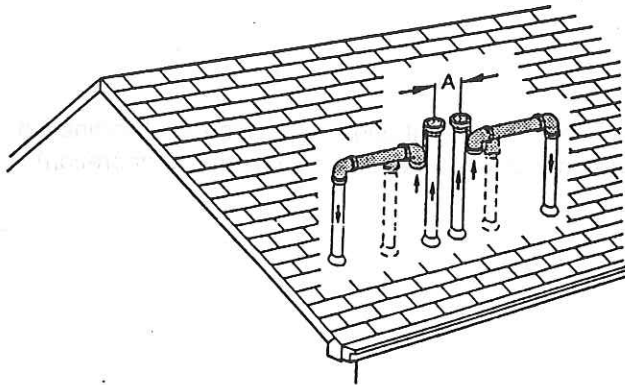

Fig. 35 Rooftop Termination (Dimension A as touching or 2-in maximum separation)

5. Disassemble loose pipe fittings. Clean and cement using same procedures as used for system piping.
6. Check required dimensions as shown in Fig 31 or 34.

#### MULTIVENTING AND VENT TERMINATION OF 355MAV FURNACE

When 2 or more direct vent furnaces are vented near each other, each furnace must be individually vented. NEVER common vent or breach vent this furnace. When 2 or more direct vent furnaces are vented near each other, 2 vent terminations may be installed as shown in Fig. 35, 36, 37, 38, or 39, but next vent termination must be at least 36 in. away from first 2 termination. It is important that vent terminations be made as shown to avoid recirculation of flue gases. Dimension A in Fig. 35, 36, 37, 38, and 39

represents distance between pipes or rain shields, as touching or 2-in maximum separation.

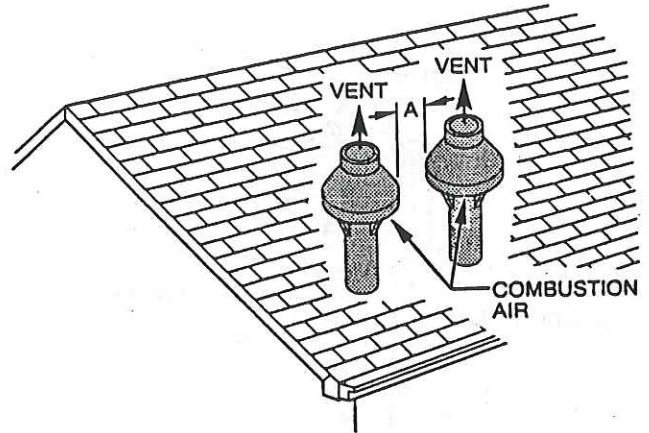

Fig. 36 - Concentric Vent and Combustion-AirRoof Termination (Dimension A as touching or 2-in maximum separation)

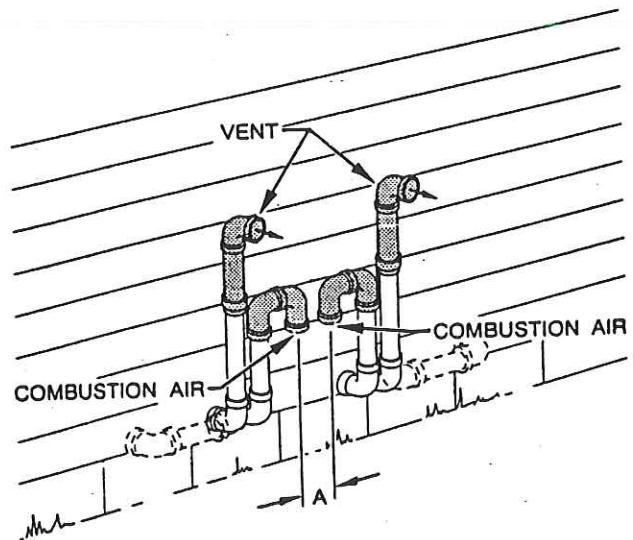

Fig. 37 - Sidewall Termination (12 in. or less) (Dimension A as touching or 2-in. maximum separation)

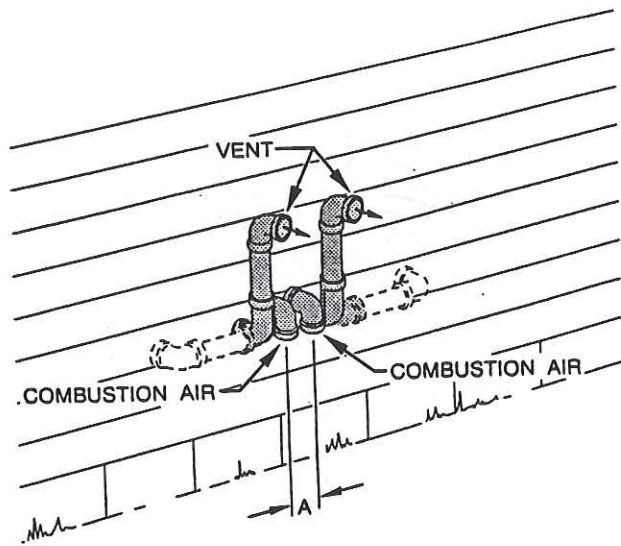

Fig. 38 - Sidewall Termination (more than 12 in.)  
(Dimension A as touching or 2-in. maximum separation)

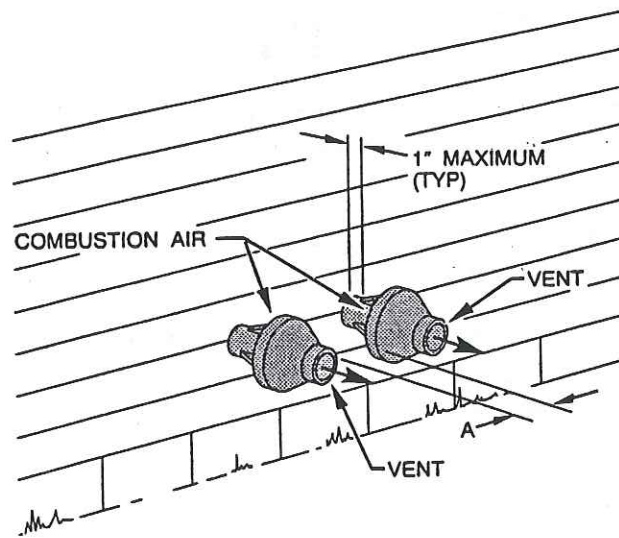

Fig. 39 - concentric Vent and Combustion Air Termination  
(Dimension A as touching or 2 in. maximum separation)



TABLE 7 - MAXIMUM ALLOWABLE PIPE LENGTH (FT)

ALTITUDE	UNIT SIZE	TERMINATION TYPE	PIPE DIAMETER (IN.)	NUMBER OF 90° ELBOWS					
				1	2	3	4	5	6
0 TO 2000	040	2 Pipe or 2-In. Concentric	1-1/2	70	70	65	65	60	55
			2	70	70	70	70	70	70
	060	2 Pipe or 2-In. Concentric	1-1/2	70	70	65	65	60	55
			2	70	70	70	70	70	70
	080	2 Pipe or 2-In. Concentric	1-1/2	40	35	25	25	22	15
			2	70	70	70	70	70	70
	100	2 Pipe or 2-In. Concentric	2	60	55	45	40	35	25
			2-1/2	70	70	70	70	70	70
2001 to 3000	040	2 Pipe or 2-In. Concentric	1-1/2	63	62	57	57	52	47
			2	70	70	70	70	70	70
	060	2 Pipe or 2-In. Concentric	1-1/2	63	62	57	57	52	47
			2	70	70	70	70	70	70
	080	2 Pipe or 2-In. Concentric	1-1/2	35	30	25	20	15	10
			2	70	70	70	70	70	70
	100	2 Pipe or 2-In. Concentric	2	54	49	39	34	29	20
			2-1/2	70	70	70	70	70	70
3001 to 4000	040	2 Pipe or 2-In. Concentric	1-1/2	59	59	54	53	48	43
			2	70	70	70	70	70	70
	060	2 Pipe or 2-In. Concentric	1-1/2	59	59	54	53	48	43
			2	70	70	70	70	70	70
	080	2 Pipe or 2-In. Concentric	1-1/2	33	28	23	18	13	8
			2	70	70	70	70	70	70
	100	2 Pipe or 2-In. Concentric	2	51	46	36	31	26	17
			2-1/2	70	70	70	70	70	70
4001 to 5000*	040	2 Pipe or 2-In. Concentric	1-1/2	56	55	50	49	44	39
			2	70	70	70	70	70	70
	060	2 Pipe or 2-In. Concentric	1-1/2	56	55	50	49	44	39
			2	70	70	70	70	70	70
	080	2 Pipe or 2-In. Concentric	1-1/2	31	26	21	16	11	6
			2-1/2	70	70	70	70	70	70
	100	2 Pipe or 2-In. Concentric	2	48	43	34	29	24	15
			2-1/2	70	70	70	70	70	70

ALTITUDE	UNIT SIZE	TERMINATION TYPE	PIPE DIAMETER (IN.)	NUMBER OF 90° ELBOWS					
				1	2	3	4	5	6
5001 to 6000*	040	2 Pipe or 2-In. Concentric	1-1/2	53	52	47	45	40	35
			2	70	70	70	70	70	70
	060	2 Pipe or 2-In. Concentric	1-1/2	53	52	47	45	40	35
			2	70	70	70	70	70	70
	080	2 Pipe or 2-In. Concentric	1-1/2	29	24	19	14	9	0
			2	70	70	70	70	70	70
	100	2 Pipe or 2-In. Concentric	2	45	40	31	26	21	12
			2-1/2	70	70	70	70	70	70
6001 to 7000*	040	2 Pipe or 2-In. Concentric	1-1/2	49	48	43	42	37	32
			2	70	70	68	67	66	64
	060	2 Pipe or 2-In. Concentric	1-1/2	49	48	43	42	37	32
			2	70	70	68	67	66	64
	080	2 Pipe or 2-In. Concentric	1-1/2	27	22	17	12	0	0
			2	70	70	68	67	66	64
	100	2 Pipe or 2-In. Concentric	2	42	37	28	23	18	10
			2-1/2	70	70	68	67	66	64
7001 to 8000*	040	2 Pipe or 2-In. Concentric	1-1/2	46	44	39	38	33	28
			2	66	65	63	62	60	59
	060	2 Pipe or 2-In. Concentric	1-1/2	46	44	39	38	33	28
			2	66	65	63	62	60	59
	080	2 Pipe or 2-In. Concentric	1-1/2	25	20	15	10	0	0
			2	66	65	63	62	60	59
	100	2 Pipe or 2 In. Concentric	2	39	34	26	21	16	0
			2-1/2	66	65	63	62	60	59
8001 to 9000*	040	2 Pipe or 2-In. Concentric	1-1/2	43	41	36	34	29	24
			2	62	60	58	56	55	53
	060	2 Pipe or 2-In. Concentric	1-1/2	43	41	36	34	29	24
			2	62	60	58	56	55	53
	080	2 Pipe or 2-In. Concentric	1-1/2	23	18	13	0	0	0
			2	62	60	58	56	55	53
	100	2 Pipe or 2-In. Concentric	2	36	31	23	18	13	5
			2-1/2	62	60	58	56	55	53
9001 to 10000*	040	2 Pipe or 2-In. Concentric	1-1/2	39	37	32	30	25	20
			2	57	55	53	51	49	47
	060	2 Pipe or 2-In. Concentric	1-1/2	39	37	32	30	25	20
			2	57	55	53	51	49	47
	080	2 Pipe or 2-In. Concentric	1-1/2	21	16	11	6	0	0
			2	57	55	53	51	49	47
	100	2 Pipe or 2-In. Concentric	2	33	28	20	15	10	0
			2-1/2	57	55	53	51	49	47

\* Vent sizing for Canadian installations over 4500 ft (1370 m) above sea level are subject to acceptance by the local authorities having jurisdiction.

NOTES:

1. Do not use pipe size greater than those specified in table or incomplete combustion, flame disturbance, or flame sense lockout may occur.
2. Size both the combustion-air and vent pipe independently, then use the larger diameter for both pipes.
3. Assume two 45° elbows equal one 90° elbow. Long radius elbows are desirable and may be required in some cases.
4. Elbows and pipe sections within the furnace casing and at the vent termination should not be included in vent length or elbow count.
5. The minimum pipe length is 5 ft for all applications.

## SEQUENCE OF OPERATION

Using schematic diagram (Fig. 23), follow sequence of operation through different modes. This furnace has a new control system. Read and follow wiring diagram carefully.

**NOTE:** If 115 v power supply to furnace or 24 v blower access panel switch is interrupted during a call for heat, blower will operate for 60 sec when power is restored before heating cycle is resumed.

### SELF-TEST MODE

The control center will go through a brief self-test whenever the 115 v or 24 v power is interrupted. The self-test will take approximately 2 sec to complete. After power is restored, the green LED will come on for 1 sec, followed by 1 sec where both the yellow and green LEDs are lit. During this time, the microprocessors is checking itself.

### HEATING MODE

When the thermostat "calls for heat", R-W/W1 closes.

1. Prepurge period - The inducer motor is turned on and slowly comes up to speed. When the low-pressure switch closes, the inducer motor RPM is noted by the microprocessor, and a 25 sec prepurge period begins. The RPM is used to evaluate the vent system resistance. This evaluation is then used to determine the require RPM necessary to operate the inducer in high or low heat modes.

**NOTE:** The heat cycle can start in either high or low heat. If a high heat cycle is initiated, the inducer will continue increasing its speed until the high-pressure switch closes before the 25 sec prepurge period will begin.

2. Humidifier (HUM) - The HUM terminal is energized when ever the inducer prepurge period is completed.
3. Ignitor warm up - At end of prepurge period, the hot surface ignitor (HSI) is energized for a 17-sec HSI warm-up period.
4. Ignition sequence - After the HSI ignitor warm-up period has completed, gas valve opens, permitting gas flow to burners where it is ignited. After 5 sec, the HSI is de-energized and a 2 sec flame sensing period begins.

**NOTE:** The initial heat mode after 115 v or 24 v power interruption will be LOW HEAT. Low heat will remain energized for 16 minutes before high heat is initiated, providing the thermostat is still "calling for heat".

er the initial cycle, the microprocessor will evaluate the length of the low and high heat operating times and calculate the optimum length of low and high heat for the

next heat cycle. This accommodates the heat load requirement seen as a result of the thermostat operating time.

5. Flame sensing - When burner flame is sensed, the control center holds gas valve open and begins the blower on delay period.

**NOTE:** Ignition sequence will repeat 3 additional times before a lockout occurs. Lockout will automatically reset after 3 hr, or can be manually reset by turning 115 v or 24 v off (not at thermostat) for 3 sec minimum, then on again.

6. Inducer speed reduction - If cycle starts in low heat, the inducer speed will reduce slightly after the flame sense, or 15 sec after flame sense if cycle starts in high heat. The reduction in speed is to optimize combustion for maximum efficiency.
7. Blower ON delay - The blower will start 60 sec after flame sense if cycle started in low heat or 35 sec after flame sense if cycle started in high heat.

**NOTE:** The blower will start at approximately 400-500 RPM. After 20 sec, the motor is turned off for 1/10 of a sec where a coast down calibration is done to evaluate the resistance of the conditioned air duct system. The microprocessor then determines the blowers RPM to provide the proper airflow for heating mode.

8. Electronic Air Cleaner (EAC) - The EAC-1 terminal is energized whenever the blower operates.
9. Blower OFF delay - When the thermostat is satisfied, the R-W signal is terminated, de-energizing the gas valve (stopping gas flow to the burner) and the HUM terminal is de-energized.

The blower will reduce its speed to the low heat RPM. The blower and electronic air cleaner will remain operating 90, 135, 180 or 225 sec (depending on the blower off time selection). The furnace is factory set for a 90 sec blower off delay.

10. Post Purge - The inducer will continue operating for 15 sec after the gas valve is de-energized.

### HEAT MODE - TWO STAGE

The control center will provide 2-stage heating using a single-stage thermostat. The control center will maximize comfort while optimizing efficiency to meet the demands of the conditioned areas when a thermostat R-W/W1 signal is received.

If thermostat control over the control center microprocessor operation is desired, a 2-stage thermostat can be used.

When the control center receives a thermostat, R-W/W1 and R-W2 signal, high heat will be energized and when R-W/W1 signal is received, low heat will be energized. This method overrides the microprocessor control of high or low heat.

NOTE: When using 2-stage thermostat operation with R-W/W1 and R-W2 signals, setup switch SW-2 MUST be in ON position. The heat cycle will operate as stated above.

### EMERGENCY HEAT MODE

NOTE: The furnace should not be operated in emergency heat mode for extended periods of times. Operation is only recommended to provide heat until replacement components can be obtained or fault resolved.

In this mode, the microprocessor is by-passed and the motors operate at full speed with high heat operation. The heat exchangers, motors, and electronics can be overstressed and may reduce the life of the components if operated for an extended period.

NOTE: No safeties are bypassed when using emergency heat mode.

Emergency heat mode will be activated automatically if the control center's microprocessor has failed and a "call for heat" is received from the thermostat.

Emergency heat mode can also be selected using setup switch (SW-4). SW-4 should be used when a fault condition exists, or difficult to resolve problems occur. This will allow heating until the fault can be corrected.

In emergency heat mode, the normal heat mode outlined above is not followed. The following sequence will occur:

1. When the thermostat "calls for heat", the R-W/W-1 circuits close.
2. Prepurge period - The inducer motor is turned on IMMEDIATELY operating at maximum speed, closing the low and high-pressure switches. Prepurge will begin 25 sec after high-pressure switch closes.
3. Blower ON - The blower motor is turned on IMMEDIATELY and slowly increases to maximum speed as soon as a "call for heat" is received. No blower calibration will occur.
4. Electronic Air Cleaner (EAC) - The EAC-1 terminal is energized whenever the blower operates.
5. Humidifier (HUM) - The HUM terminal is energized whenever the inducer prepurge period is completed.
6. Ignitor warm-up - The HSI is energized for a 17 sec warm-up period after the prepurge period is completed.
7. Ignition sequence - After the HSI warm-up period has completed, the gas valve is energized, permitting gas

flow to the burners where it is ignited. After 5 sec, the HSI is de-energized and a 2 sec flame sensing period begins.

NOTE: Emergency heat mode will only operate in high heat.

8. Flame sensing - When burner flame is sensed, the control center holds the gas valve open. If burner flame is not sensed, the control center will de-energize the gas valve and the ignition sequence is repeated.
9. Blower OFF delay - When the thermostat is satisfied, the R-W/W1 is terminated, de-energizing the gas valve (stopping gas flow to the burners) and the HUM terminal is de-energized. In addition, the blower will stop immediately.
10. Post purge - Post purge will NOT occur. The inducer will stop immediately.

### ADJUSTING COOLING VALVE:

Turning valve on the variable-capacity furnace is not necessary since the inducer motor speed is calculated at each cycle to provide the maximum efficiency.

Turning valve should be adjusted to the maximum open position.

- a. Rotate tuning valve counter clockwise until stops on tuning valve hit pins on inducer housing.
- b. Rotate tuning valve clockwise 2 notches to ensure valve is locked in place and gasket is sealed.

Table 11 - Setup Switch Description

SETUP SWITCH NO.	NORMAL POSITION	DESCRIPTION OF USE
SW-1 (FLT)	OFF	Turn switch ON for fault history display. No thermostat signal can be present for fault history display.
SW-2 (LOW)	OFF	Turn switch to ON to lock furnace in the low heat mode only.
SW-3 (BPH)	OFF	Turn switch to ON when a bypass humidifier is used. This will compensate for the higher return-air temperature and provide 10 percent more airflow.
SW-4 (EMER HEAT)*	OFF	Turn switch to ON to bypass microprocessor control. Furnace will operate at high heat only with main blower and inducer motor operating at maximum RPM. NO safeties are bypassed.
SW-5 (MZ)	OFF	Turn switch to ON when modulating dampers are used. In this mode the main blower speed is recalculated once every minute while the furnace is in the low-heat or continuous fan mode.
SW-6 (COMP TEST)	OFF	Turn switch to ON to initiate component test. Furnace will operate inducer motor 20 sec low speed, 20 sec high speed, HSI 15 sec, blower 20 sec low speed, blower 20 sec high speed. SW-1 must be in OFF position. No thermostat signal can be present for fault history display.
SW-7 and 8 (Blower Off Delay)	See Table 12	Adjust switches to provide desired heating mode blower off delay time, 90, 135, 180 or 225 sec.

DESIRED HEATING MODE BLOWER OFF DELAY (SEC)	SETUP SWITCH (SW-7 AND -8) POSITION	
	SW-7	SW-8
90	OFF	OFF
135	ON	OFF
180	OFF	ON
225	ON	ON

Table 12 - Blower Off Delay Setup Switch Position

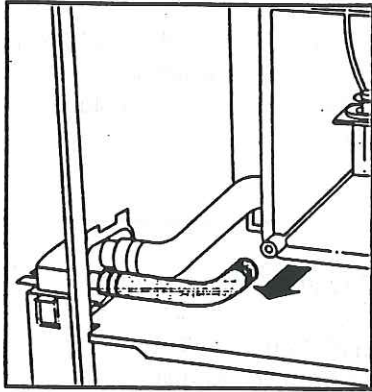

Fig. 41 - Inducer Housing Drain Tube

#### FILL CONDENSATE TRAP WITH WATER

- Disconnect condensate drain tube from inducer housing (medium diameter tube on condensate drain trap). (See Fig. 41)
- Insert funnel into tube and pour 1 quart of water into tube. This should overflow the trap and flow into an open drain (See Fig. 42)
- Reconnect drain tube to inducer housing.

**PURGE GAS LINES** - If not previously done, purge the lines after all connections have been made and check for leaks.

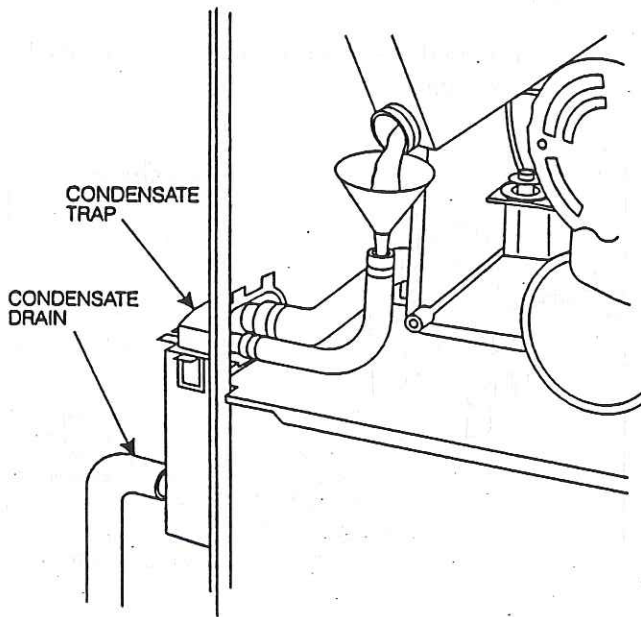

Fig. 42 - Filling Condensate Trap

**COMPONENT TEST** - The furnace control center allows all components, except the gas valve, to be run for a short period of time. See below for operation sequence.

This feature helps diagnose a system problem in the case of a component failure. To initiate the component-test procedure, turn setup switch SW-6 to ON position (See Fig. 25)

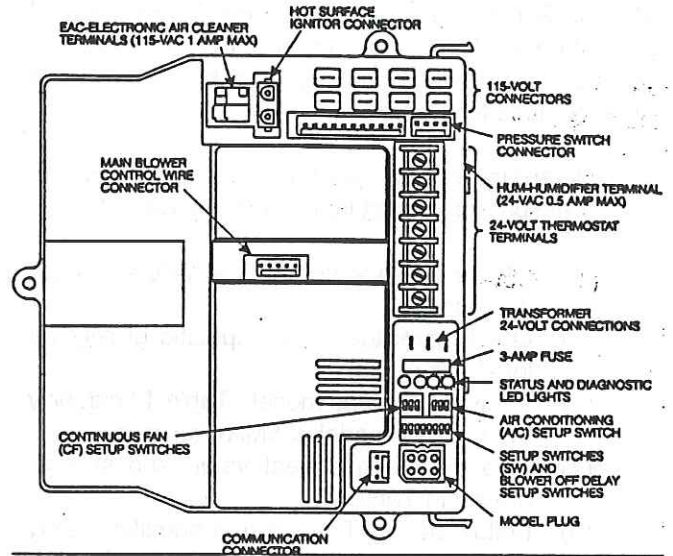

Figure 25 - Control Center

**NOTE:** Setup switch No. 1 **MUST** be in OFF position or fault code 22 - setup error, will occur.

**NOTE:** The component test gear will not operate if the control center is receiving any thermostat signal.

#### THE COMPONENT SEQUENCE IS AS FOLLOWS:

- Setup switch 6 (SW-6) turned ON.
- The inducer motor operates for 20 sec at low speed, 20 sec at high speed, then turns off.
- The HSI is then energized for 15 sec, then turns off.
- The blower motor operates on low speed for 20 sec, then off.
- The blower motor operates on high speed for 20 sec, then turns off.
- When component test is completed, one or more fault codes 11, 22, 41 or 42 will flash. Refer to furnace Fault Code label for information regarding these codes.
- To repeat component test turn setup switch SW-6 to OFF and then back to ON.
- After component test is completed turn setup switch SW-6 to OFF position.

To operate furnace, follow procedures on operating instruction label attached to furnace.

With furnace operating, set thermostat below room temperature and observe that furnace goes off. Set thermostat above room temperature and observe that furnace restarts.

## ADJUSTMENTS

1. Set gas input rate.
2. There are two methods of adjusting gas input rate. The preferred method is by using Table 13 and procedure a. The second method is by clocking the gas meter as outlined in procedure b. Procedure b must be used for altitudes above 2,000 ft.

a. Determine natural gas orifice size and manifold pressure for correct input by using Table 13.

- (1) Obtain average yearly heat value for local gas supply.
- (2) Obtain average yearly specific gravity for local gas supply.
- (3) Verify the furnace model. Table 13 can only be used for model 355MAV furnaces.
- (4) Find natural gas heat value and specific gravity in Table 13.
- (5) Follow heat value line and specific gravity line to point of intersection to find orifice size and manifold pressure settings for proper operation at given natural gas condition.

### EXAMPLE:

Heat value 1040 Btu/cu ft

Specific gravity 0.62

Therefore; orifice #45\* with manifold pressure 3.7 in. w.c. for high heat and 1.6 in. w.c. for low heat.

\*The furnace is shipped with #44 orifices. In this example all main burner orifices must be changed and the manifold pressure adjusted.

- (6) Check and verify orifice size in furnace. NEVER ASSUME THE ORIFICE SIZE; ALWAYS CHECK AND VERIFY.
- (7) Proceed to procedure c to adjust manifold pressure.
- (8) Check input rate by clocking meter as described in procedure b.

b. Determine natural gas input rate by clocking gas meter and adjusting manifold pressure per procedure c.

NOTE: Be sure all pressure tubing, combustion-air and vent pipes, and burner enclosure front are in place when checking input by clocking the gas meter.

- (1) Obtain average yearly heat value for local gas supply.

NOTE: Be sure heating value of gas used for calculation is correct for your altitude. Consult local gas utility for altitude adjustments of gas heating value.

- (2) Turn off all other gas appliances and pilots.
- (3) Start furnace and let run for 3 minutes.
- (4) Measure time (in sec) for gas meter test dial to complete 1 revolution.
- (5) Refer to Table 14 for cubic ft of gas per hr.
- (6) Multiply gas rate (cu ft/hr) X heating value (Btu/cu ft). Obtain heating value from local gas utility.

### EXAMPLE:

Heat value input = Btu/cu ft X cu ft

Heat value 1040 Btu/cu ft

Time for 1 revolution of 2-cu ft dial = 74 sec

Gas rate = 97 cu ft/hr (from Table 14)

Btu heating input = 97 x 1040 = 100,880

- (7) Measured gas input must not exceed gas input on unit rating plate.

NOTE: High altitude: gas input on rating plate is for altitudes up to 2,000 ft. Ratings for altitudes over 2,000 ft must be 4 percent less for each 1000 ft above sea level. To obtain the altitude adjusted rating, adjust the manifold pressure, procedure c, and replace the main burner orifices as needed. Refer to National Fuel Gas Code Appendix F, Table F-4 for proper orifice sizing at high altitudes or MFS Good Practice Book.

NOTE: In Canada, from 2000 to 4500 ft above sea level, derate the unit 10 percent from the Conversion Station.

- (8) Proceed to item c. to adjust manifold pressure.

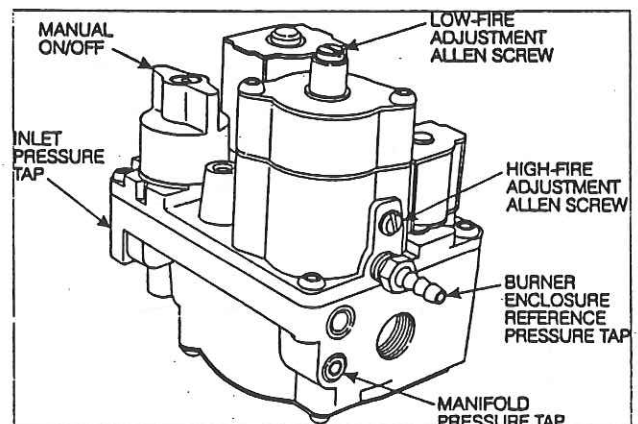

Fig. 43 - Redundant Automatic Gas Valve

- c. Adjust gas input.

NOTE: Manifold pressure must always be measured with the burner enclosure FRONT REMOVED. The gas meter must always be clocked with the burner enclosure FRONT INSTALLED. The gas valve has been nominally set at 3.5 w.c. high heat and 1.5 in w.c. low heat for natural gas.

- (1) Remove burner enclosure front and caps that conceal adjustment screws for gas valve regulators. (See Fig. 42)
- (2) Turn setup switch SW-2 on control center to ON position. (See Fig. 25) This will keep furnaces locked in low heat operation.
- (3) Turn low heat adjusting screw (5/64 hex Allen wrench) counterclockwise (out) to decrease input rate or clockwise (in) to increase rate. When adjusting input rate, DO NOT set manifold pressure less than 1.3 in or more than 1.7 in w.c. for natural gas. Make any major adjustments by changing main burner orifices.
- (4) Turn setup switch SW-2 to OFF position after low fire adjustment.
- (5) Jumper R-W2 on control thermostat connections. (See Fig.25) This will keep furnace locked in high heat operations.
- (6) Turn high heat adjusting screw (5/64 hex Allen wrench) counterclockwise (out) to decrease input rate, DO NOT set manifold pressure less than 3.2 in or more than 3.8 in. w.c. for natural gas. Make any major adjustment by changing main burner orifices.

NOTE: If orifices are changed, both high heat and low heat input rate must be readjusted.

NOTE: If orifice hole appears damaged or it is suspected to have been redrilled, check the orifice hole with a numbered drill bit of the correct size. Never redrill an orifice. A burr-free and squarely aligned orifice hole is essential for proper flame characteristics.

- (7) Remove jumper R-W2 after high heat adjustment.
- (8) Replace burner enclosure front and measure adjusted gas input rate using method outlined in procedure b.
- (9) Replace caps that conceal gas valve regulator adjustment screws.

CAUTION: DO NOT redrill orifices. Improper drilling (burrs, out-of-round holes, etc.) can cause excessive burner noise and misdirection of burner flames. This can result in flame impingement of the burners and heat exchangers causing failures.

CAUTION: Be sure burner enclosure front is in place after adjustments have been made.

SECONDS FOR 1 REVOLUTION	SIZE OF TEST DIAL			SECONDS FOR 1 REVOLUTION	SIZE OF TEST DIAL		
	1 cu ft	2 cu ft	5 cu ft		1 cu ft	2 cu ft	5 cu ft
10	360	720	1800	50	72	144	360
11	327	655	1636	51	71	141	355
12	300	600	1500	52	69	138	346
13	277	555	1385	53	68	136	340
14	257	514	1286	54	67	133	333
15	240	480	1200	55	65	131	327
16	225	450	1125	56	64	129	321
17	212	424	1059	57	63	126	316
18	200	400	1000	58	62	124	310
19	189	379	947	59	61	122	305
20	180	360	900	60	60	120	300
21	171	343	857	62	58	116	290
22	164	327	818	64	56	112	281
23	157	313	783	66	54	109	273
24	150	300	750	68	53	106	265
25	144	288	720	70	51	103	257
26	138	277	692	72	50	100	250
27	133	267	667	74	48	97	243
28	129	257	643	76	47	95	237
29	124	248	621	78	46	92	231
30	120	240	600	80	45	90	225
31	116	232	581	82	44	88	220
32	113	225	563	84	43	86	214
33	109	218	545	86	42	84	209
34	106	212	529	88	41	82	205
35	103	206	514	90	40	80	200
36	100	200	500	92	39	78	196
37	97	195	486	94	38	76	192
38	95	189	474	96	38	75	188
39	92	185	462	98	37	74	184
40	90	180	450	100	36	72	180
41	88	176	439	102	35	71	178
42	86	172	429	104	35	69	173
43	84	167	419	106	34	68	170
44	82	164	409	108	33	67	167
45	80	160	400				164
46	78	157	391	110	33	65	161
47	76	153	383	112	32	64	155
48	75	150	375	116	31	62	150
49	73	147	367	120	30	60	150

Table 14 - Gas Rate CU FT/HR





355 MAU

MODEL	JUMPERS
042040	1-4 2-5 3-6
042060	X X X X
042080	X X X X
042100	X X X X

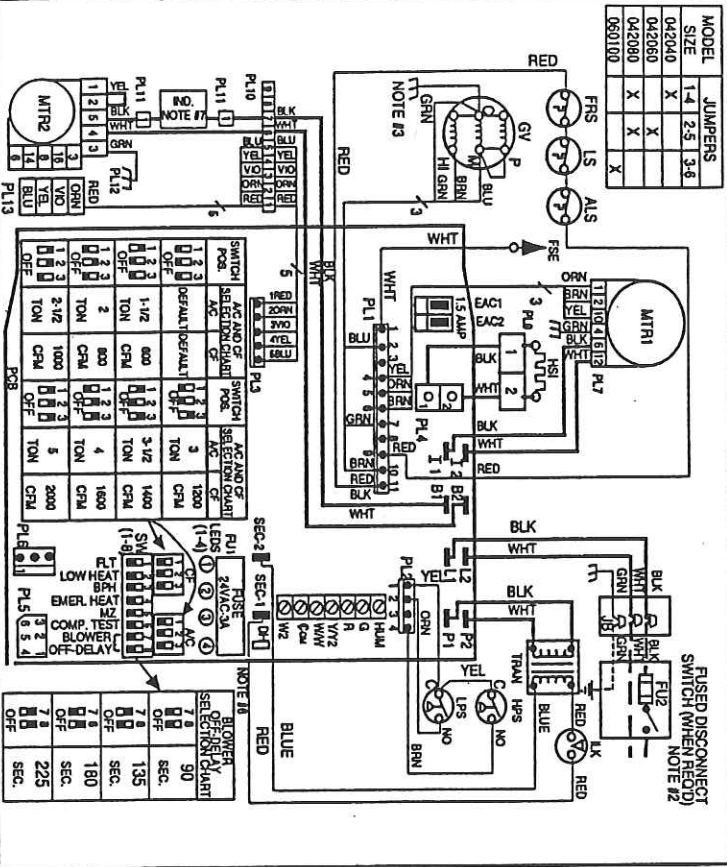

AC AMP OF	SWITCH	AC AMP OF	SWITCH	AC AMP OF	SWITCH
1 1/2	OFF	1 1/2	OFF	1 1/2	OFF
2	OFF	2	OFF	2	OFF
3	OFF	3	OFF	3	OFF
4	OFF	4	OFF	4	OFF
5	OFF	5	OFF	5	OFF
7 1/2	OFF	7 1/2	OFF	7 1/2	OFF
10	OFF	10	OFF	10	OFF
15	OFF	15	OFF	15	OFF
20	OFF	20	OFF	20	OFF
25	OFF	25	OFF	25	OFF
30	OFF	30	OFF	30	OFF
35	OFF	35	OFF	35	OFF
40	OFF	40	OFF	40	OFF
45	OFF	45	OFF	45	OFF
50	OFF	50	OFF	50	OFF
60	OFF	60	OFF	60	OFF
75	OFF	75	OFF	75	OFF
100	OFF	100	OFF	100	OFF
150	OFF	150	OFF	150	OFF
200	OFF	200	OFF	200	OFF

- LEGEND**
- AC AIR CONDITIONING (ADJUSTABLE TONNAGE)
  - ALS AUXILIARY LIGHT SWITCH
  - ALS OVERTEMP - MANUAL RESET SPST (N.O.)
  - CF CONTINUOUS FAN (ADJUSTABLE CFM)
  - CPM CONTINUOUS FAN (FIXED CFM)
  - CPM2 CONTINUOUS FAN (FIXED CFM) - 2
  - CPM3 CONTINUOUS FAN (FIXED CFM) - 3
  - CPM4 CONTINUOUS FAN (FIXED CFM) - 4
  - CPM5 CONTINUOUS FAN (FIXED CFM) - 5
  - CPM6 CONTINUOUS FAN (FIXED CFM) - 6
  - CPM7 CONTINUOUS FAN (FIXED CFM) - 7
  - CPM8 CONTINUOUS FAN (FIXED CFM) - 8
  - CPM9 CONTINUOUS FAN (FIXED CFM) - 9
  - CPM10 CONTINUOUS FAN (FIXED CFM) - 10
  - CPM11 CONTINUOUS FAN (FIXED CFM) - 11
  - CPM12 CONTINUOUS FAN (FIXED CFM) - 12
  - CPM13 CONTINUOUS FAN (FIXED CFM) - 13
  - CPM14 CONTINUOUS FAN (FIXED CFM) - 14
  - CPM15 CONTINUOUS FAN (FIXED CFM) - 15
  - CPM16 CONTINUOUS FAN (FIXED CFM) - 16
  - CPM17 CONTINUOUS FAN (FIXED CFM) - 17
  - CPM18 CONTINUOUS FAN (FIXED CFM) - 18
  - CPM19 CONTINUOUS FAN (FIXED CFM) - 19
  - CPM20 CONTINUOUS FAN (FIXED CFM) - 20
  - CPM21 CONTINUOUS FAN (FIXED CFM) - 21
  - CPM22 CONTINUOUS FAN (FIXED CFM) - 22
  - CPM23 CONTINUOUS FAN (FIXED CFM) - 23
  - CPM24 CONTINUOUS FAN (FIXED CFM) - 24
  - CPM25 CONTINUOUS FAN (FIXED CFM) - 25
  - CPM26 CONTINUOUS FAN (FIXED CFM) - 26
  - CPM27 CONTINUOUS FAN (FIXED CFM) - 27
  - CPM28 CONTINUOUS FAN (FIXED CFM) - 28
  - CPM29 CONTINUOUS FAN (FIXED CFM) - 29
  - CPM30 CONTINUOUS FAN (FIXED CFM) - 30
  - CPM31 CONTINUOUS FAN (FIXED CFM) - 31
  - CPM32 CONTINUOUS FAN (FIXED CFM) - 32
  - CPM33 CONTINUOUS FAN (FIXED CFM) - 33
  - CPM34 CONTINUOUS FAN (FIXED CFM) - 34
  - CPM35 CONTINUOUS FAN (FIXED CFM) - 35
  - CPM36 CONTINUOUS FAN (FIXED CFM) - 36
  - CPM37 CONTINUOUS FAN (FIXED CFM) - 37
  - CPM38 CONTINUOUS FAN (FIXED CFM) - 38
  - CPM39 CONTINUOUS FAN (FIXED CFM) - 39
  - CPM40 CONTINUOUS FAN (FIXED CFM) - 40
  - CPM41 CONTINUOUS FAN (FIXED CFM) - 41
  - CPM42 CONTINUOUS FAN (FIXED CFM) - 42
  - CPM43 CONTINUOUS FAN (FIXED CFM) - 43
  - CPM44 CONTINUOUS FAN (FIXED CFM) - 44
  - CPM45 CONTINUOUS FAN (FIXED CFM) - 45
  - CPM46 CONTINUOUS FAN (FIXED CFM) - 46
  - CPM47 CONTINUOUS FAN (FIXED CFM) - 47
  - CPM48 CONTINUOUS FAN (FIXED CFM) - 48
  - CPM49 CONTINUOUS FAN (FIXED CFM) - 49
  - CPM50 CONTINUOUS FAN (FIXED CFM) - 50
  - CPM51 CONTINUOUS FAN (FIXED CFM) - 51
  - CPM52 CONTINUOUS FAN (FIXED CFM) - 52
  - CPM53 CONTINUOUS FAN (FIXED CFM) - 53
  - CPM54 CONTINUOUS FAN (FIXED CFM) - 54
  - CPM55 CONTINUOUS FAN (FIXED CFM) - 55
  - CPM56 CONTINUOUS FAN (FIXED CFM) - 56
  - CPM57 CONTINUOUS FAN (FIXED CFM) - 57
  - CPM58 CONTINUOUS FAN (FIXED CFM) - 58
  - CPM59 CONTINUOUS FAN (FIXED CFM) - 59
  - CPM60 CONTINUOUS FAN (FIXED CFM) - 60
  - CPM61 CONTINUOUS FAN (FIXED CFM) - 61
  - CPM62 CONTINUOUS FAN (FIXED CFM) - 62
  - CPM63 CONTINUOUS FAN (FIXED CFM) - 63
  - CPM64 CONTINUOUS FAN (FIXED CFM) - 64
  - CPM65 CONTINUOUS FAN (FIXED CFM) - 65
  - CPM66 CONTINUOUS FAN (FIXED CFM) - 66
  - CPM67 CONTINUOUS FAN (FIXED CFM) - 67
  - CPM68 CONTINUOUS FAN (FIXED CFM) - 68
  - CPM69 CONTINUOUS FAN (FIXED CFM) - 69
  - CPM70 CONTINUOUS FAN (FIXED CFM) - 70
  - CPM71 CONTINUOUS FAN (FIXED CFM) - 71
  - CPM72 CONTINUOUS FAN (FIXED CFM) - 72
  - CPM73 CONTINUOUS FAN (FIXED CFM) - 73
  - CPM74 CONTINUOUS FAN (FIXED CFM) - 74
  - CPM75 CONTINUOUS FAN (FIXED CFM) - 75
  - CPM76 CONTINUOUS FAN (FIXED CFM) - 76
  - CPM77 CONTINUOUS FAN (FIXED CFM) - 77
  - CPM78 CONTINUOUS FAN (FIXED CFM) - 78
  - CPM79 CONTINUOUS FAN (FIXED CFM) - 79
  - CPM80 CONTINUOUS FAN (FIXED CFM) - 80
  - CPM81 CONTINUOUS FAN (FIXED CFM) - 81
  - CPM82 CONTINUOUS FAN (FIXED CFM) - 82
  - CPM83 CONTINUOUS FAN (FIXED CFM) - 83
  - CPM84 CONTINUOUS FAN (FIXED CFM) - 84
  - CPM85 CONTINUOUS FAN (FIXED CFM) - 85
  - CPM86 CONTINUOUS FAN (FIXED CFM) - 86
  - CPM87 CONTINUOUS FAN (FIXED CFM) - 87
  - CPM88 CONTINUOUS FAN (FIXED CFM) - 88
  - CPM89 CONTINUOUS FAN (FIXED CFM) - 89
  - CPM90 CONTINUOUS FAN (FIXED CFM) - 90
  - CPM91 CONTINUOUS FAN (FIXED CFM) - 91
  - CPM92 CONTINUOUS FAN (FIXED CFM) - 92
  - CPM93 CONTINUOUS FAN (FIXED CFM) - 93
  - CPM94 CONTINUOUS FAN (FIXED CFM) - 94
  - CPM95 CONTINUOUS FAN (FIXED CFM) - 95
  - CPM96 CONTINUOUS FAN (FIXED CFM) - 96
  - CPM97 CONTINUOUS FAN (FIXED CFM) - 97
  - CPM98 CONTINUOUS FAN (FIXED CFM) - 98
  - CPM99 CONTINUOUS FAN (FIXED CFM) - 99
  - CPM100 CONTINUOUS FAN (FIXED CFM) - 100

Wiring Diagram

TO 115 VAC FIELD DISCONNECT  
NOTE #2  
EQUIPMENT GROUND  
SCHEMATIC DIAGRAM  
(NATURAL GAS & PROPANE)

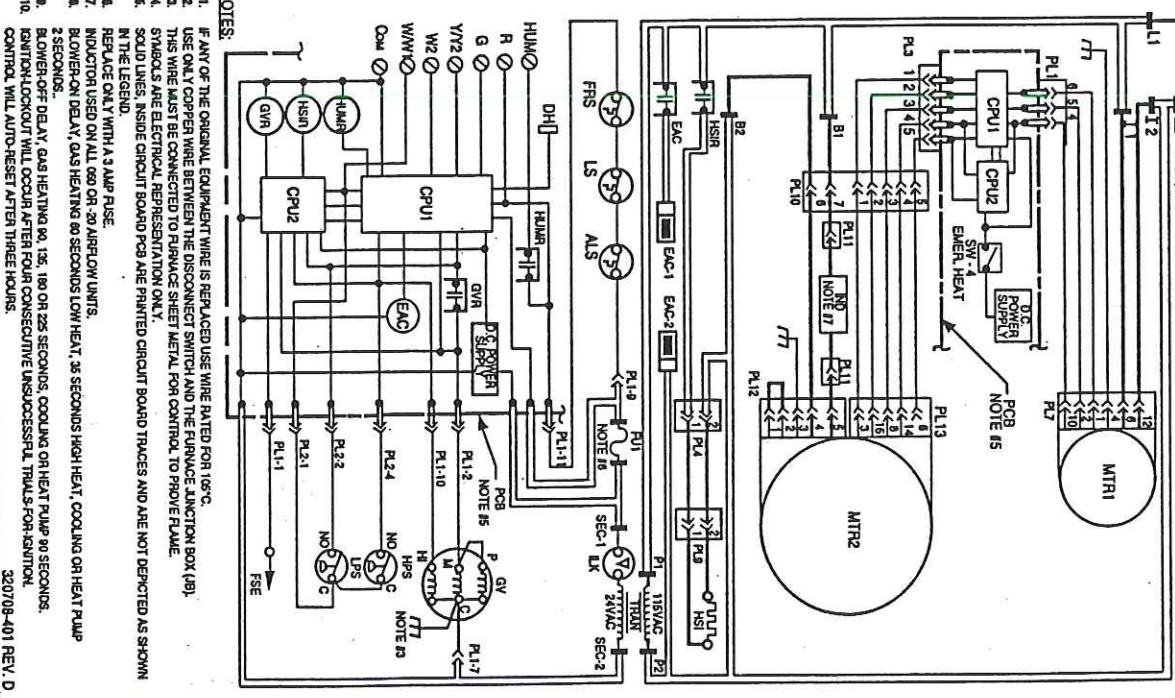

- NOTES:**
- IF ANY OF THE ORIGINAL EQUIPMENT WIRE IS REPLACED USE WIRE RATED FOR 100°C.
  - USE ONLY COPPER WIRE WHEN THE DISCONNECT SWITCH AND THE FURNACE JUNCTION BOX (JB).
  - THIS WIRE MUST BE CONNECTED TO FURNACE SHEET METAL FOR CONTROL TO PROVIDE FLAME.
  - SYMBOLS ARE ELECTRICAL REPRESENTATION ONLY.
  - SOLID LINES: INSIDE CIRCUIT BOARD PCB ARE PRINTED CIRCUIT BOARD TRACES AND ARE NOT DEPicted AS SHOWN IN THE LEGEND.
  - REPLACE ONLY WITH A 3 AMP FUSE.
  - INDUCTOR USED ON ALL 600 OR 20 AMP LOW UNITS.
  - BLOWN-ON DELAY, GAS HEATING 60 SECONDS LOW HEAT, 35 SECONDS HIGH HEAT, COOLING OR HEAT PUMP 2 SECONDS.
  - BLOWN-OFF DELAY, GAS HEATING 90, 135, 180 OR 225 SECONDS. COOLING OR HEAT PUMP 90 SECONDS.
  - IGNITION-LOCKOUT WILL OCCUR AFTER FOUR CONSECUTIVE UNSUCCESSFUL TRIALS FOR IGNITION.
  - CONTROL WILL AUTO-RESET AFTER THREE HOURS.

A93061



TO 115 VAC FIELD DISCONNECT  
NOTE #2

SCHEMATIC DIAGRAM  
(NATURAL GAS & PROPANE)

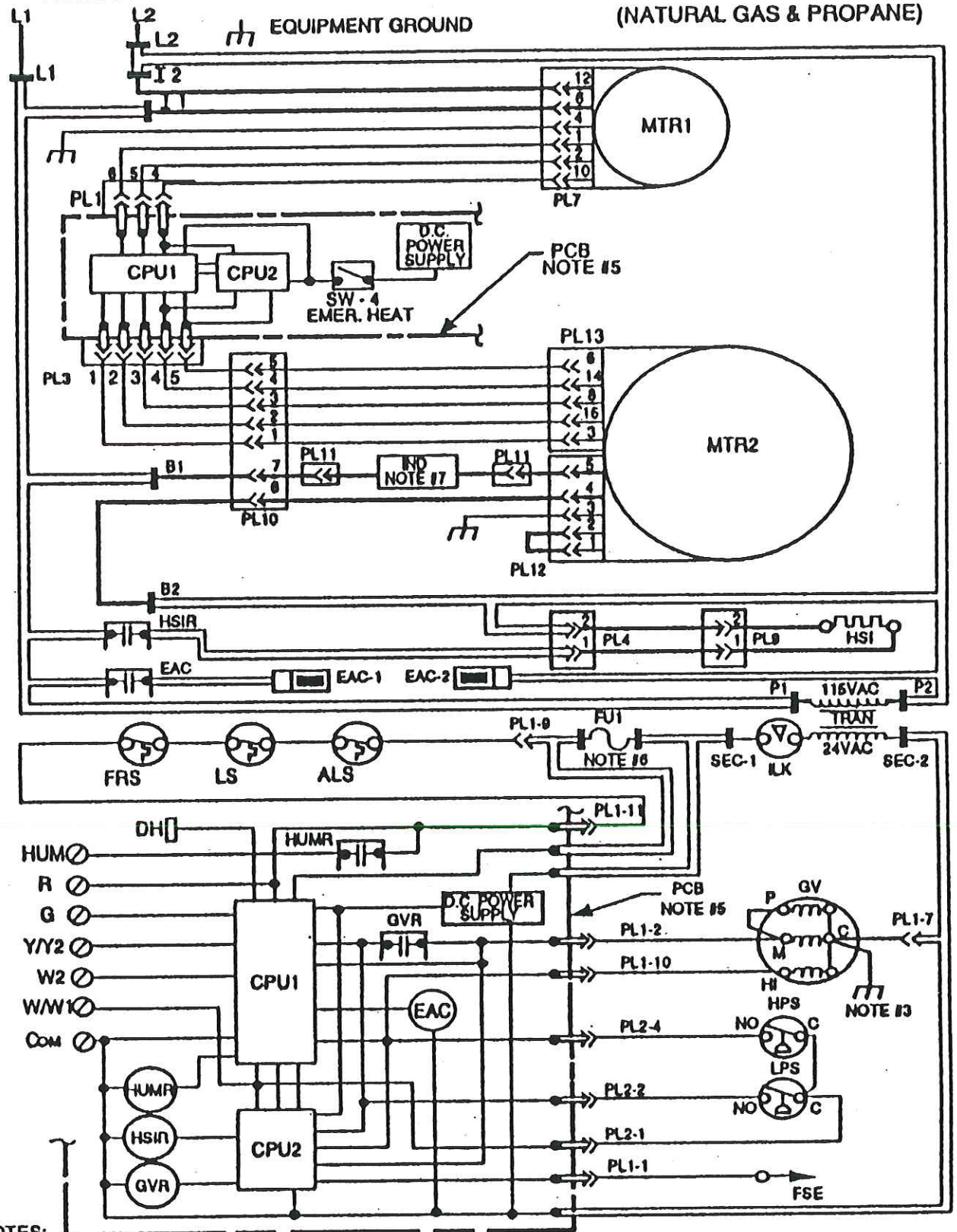

NOTES:

1. IF ANY OF THE ORIGINAL EQUIPMENT WIRE IS REPLACED USE WIRE RATED FOR 105°C.
2. USE ONLY COPPER WIRE BETWEEN THE DISCONNECT SWITCH AND THE FURNACE JUNCTION BOX (JB).
3. THIS WIRE MUST BE CONNECTED TO FURNACE SHEET METAL FOR CONTROL TO PROVE FLAME.
4. SYMBOLS ARE ELECTRICAL REPRESENTATION ONLY.
5. SOLID LINES, INSIDE CIRCUIT BOARD PCB ARE PRINTED CIRCUIT BOARD TRACES AND ARE NOT DEPICTED AS SHOWN IN THE LEGEND.
6. REPLACE ONLY WITH A 3 AMP FUSE.
7. INDUCTOR USED ON ALL 060 OR -20 AIRFLOW UNITS.
8. BLOWER-ON DELAY, GAS HEATING 60 SECONDS LOW HEAT, 35 SECONDS HIGH HEAT, COOLING OR HEAT PUMP 2 SECONDS..
9. BLOWER-OFF DELAY, GAS HEATING 90, 135, 180 OR 225 SECONDS, COOLING OR HEAT PUMP 90 SECONDS.
10. IGNITION-LOCKOUT WILL OCCUR AFTER FOUR CONSECUTIVE UNSUCCESSFUL TRIALS-FOR-IGNITION.



MODEL SIZE	JUMPERS		
	1-4	2-5	3-6
042040	X		
042060		X	
042080	X	X	
060100			X

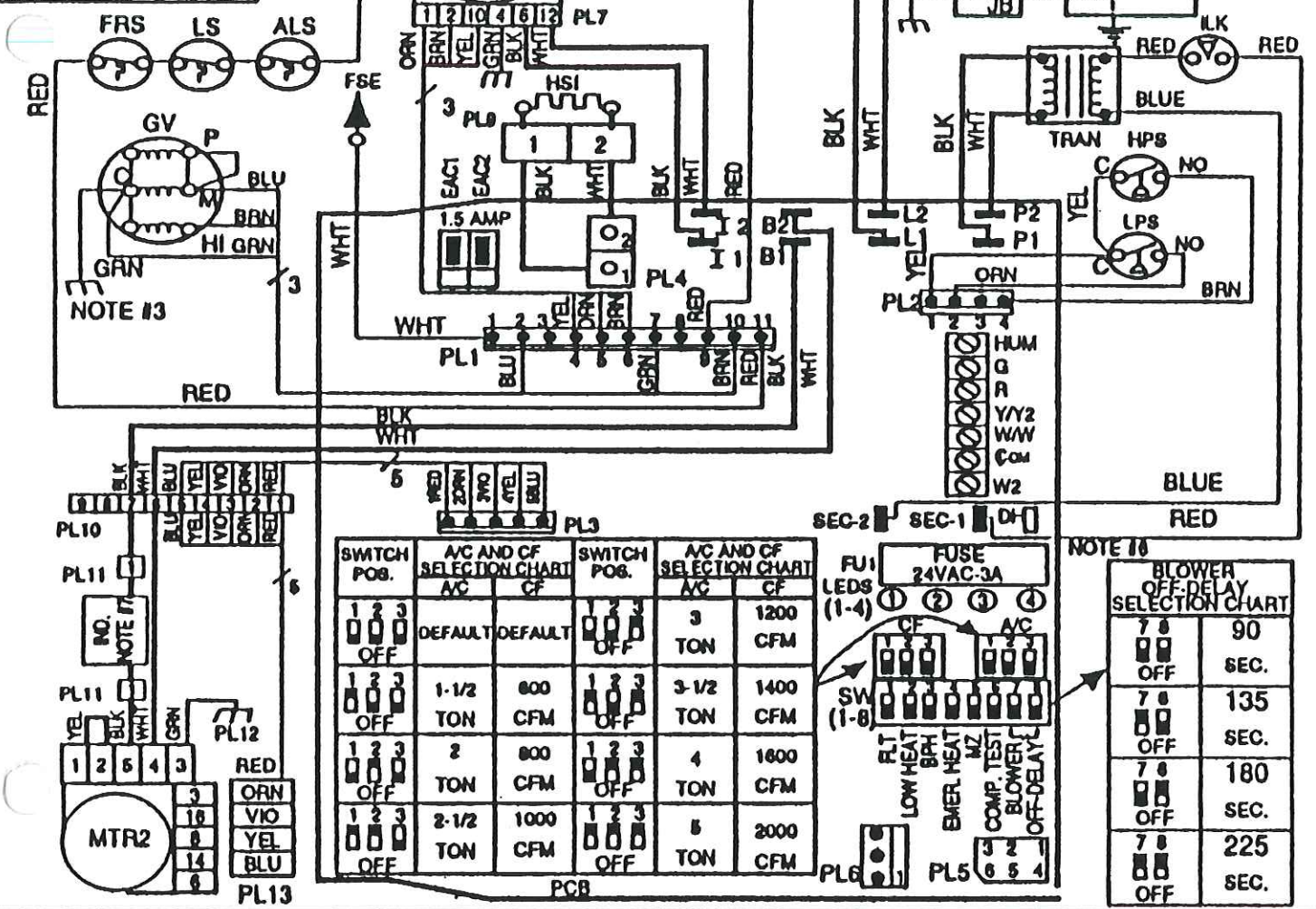

SWITCH POS.	A/C AND CF SELECTION CHART		SWITCH POS.	A/C AND CF SELECTION CHART	
	AC	CF		AC	CF
1 2 3 OFF	DEFAULT	DEFAULT	1 2 3 OFF	3	1200
1 2 3 OFF	1-1/2 TON	800 CFM	1 2 3 OFF	3-1/2 TON	1400 CFM
1 2 3 OFF	2 TON	800 CFM	1 2 3 OFF	4 TON	1600 CFM
1 2 3 OFF	2-1/2 TON	1000 CFM	1 2 3 OFF	5 TON	2000 CFM

FU1 LEADS (1-4)	FUZE 24VAC-3A	
	CF	AC
1 2 3 4	OFF	OFF
1 2 3 4	ON	ON

BLOWER OFF-DELAY SELECTION CHART	
7 8 OFF	90 SEC.
7 8 OFF	135 SEC.
7 8 OFF	180 SEC.
7 8 OFF	225 SEC.

**LEGEND**

- AC AIR CONDITIONING (ADJUSTABLE TONNAGE)
- ALS AUXILIARY LIMIT SWITCH
- CF CONTINUOUS FAN (ADJUSTABLE CFM)
- CPU1 MAIN MICROPROCESSOR & CIRCUITRY
- CPU2 IGNITION MICROPROCESSOR & CIRCUITRY
- DH DEHUMIDIFICATION CONNECTION (24VAC .02 AMPS)
- EAC-1 ELECTRONIC AIR CLEANER CONNECTION (115 VAC 1.5 AMP MAX.)
- EAC-2 ELECTRONIC AIR CLEANER CONNECTION (COMMON)
- FRS FLAME ROLLOUT SWITCH - MANUAL RESET, SPST-(N.C.)
- FSE FLAME PROVING SENSOR ELECTRODE
- FU1 FUSE, 3 AMP, AUTOMOTIVE BLADE TYPE, FACTORY INSTALLED
- FU2 FUSE OR CIRCUIT BREAKER CURRENT INTERRUPT DEVICE (FIELD INSTALLED & SUPPLIED)
- GV GAS VALVE
- GVR GAS VALVE RELAY, DPST-(N.O.)
- HI GAS VALVE HIGH STAGE OPERATOR
- HPS HIGH HEAT PRESSURE SWITCH, SPST-(N.O.)
- HSI HOT SURFACE IGNITOR (115 VAC)
- HSIR HOT SURFACE IGNITOR RELAY, SPST-(N.O.)
- HUM 24VAC HUMIDIFIER CONNECTION (5 AMP. MAX.)
- HUMR HUMIDIFIER RELAY, SPST-(N.O.)
- ILK BLOWER ACCESS PANEL INTERLOCK SWITCH, SPST-(N.O.)
- IND INDUCTOR (NOTE #7)
- JB JUNCTION BOX
- LEDS LIGHT EMITTING DIODES FOR STATUS CODES
- \_PS LOW HEAT PRESSURE SWITCH, SPST-(N.O.)
- LS LIMIT SWITCH, AUTO RESET, (N.C.)
- MTR1 MOTOR (ICM) INDUCER
- MTR2 MOTOR (ICM) BLOWER
- PCB PRINTED CIRCUIT BOARD
- PL1 11-CIRCUIT CONNECTOR
- PL2 4-CIRCUIT PRESSURE SWITCH CONNECTOR
- PL3 5-CIRCUIT BLOWER MTR CONNECTOR
- PL4 2-CIRCUIT HSI CONNECTOR
- PL5 6-CIRCUIT MODEL PLUG

- PL6 3-CIRCUIT COMM. CONNECTOR
  - PL7 12-CIRCUIT INDUCER MTR CONNECTOR
  - PL9 2-CIRCUIT HSI CONNECTOR
  - PL10 8-CIRCUIT BLOWER ADAPTER CONNECTOR
  - PL11 1-CIRCUIT INDUCER SPLICE CONNECTOR
  - PL12 6-CIRCUIT BLOWER POWER CONNECTOR
  - PL13 16-CIRCUIT BLOWER CTRL. CONNECTOR
  - SW1 MANUAL SWITCH, FAULT DISPLAY, SPST-(N.O.)
  - SW2 MANUAL SWITCH, LOW HEAT, SPST-(N.O.)
  - SW3 MANUAL SWITCH, BYPASS HUMIDIFIER, SPST-(N.O.)
  - SW4 MANUAL SWITCH, EMERGENCY HEAT, SPST-(N.O.)
  - SW5 MANUAL SWITCH, MULTIPLE ZONE, SPST-(N.O.)
  - SW6 COMPONENT TEST, SPST-(N.O.)
  - SW7-8 MANUAL SWITCH, BLOWER OFF-DELAY, SPST-(N.O.)
  - TRAN TRANSFORMER - 115VAC/24VAC
- JUNCTION
  - UNMARKED TERMINAL
  - PCB TERMINAL (FACTORY CONNECTED)
  - FACTORY WIRING (115 VAC)
  - FACTORY WIRING (24 VAC)
  - FIELD WIRING (115 VAC)
  - CONDUCTOR ON PCB
  - FIELD WIRING SCREW TERMINAL
  - TERMINAL BLOCK - MARKED TERMINAL
  - FIELD GROUND
  - EQUIPMENT GROUND
  - FIELD SPLICE
  - PCB TERMINAL (FIELD CONNECTION)
  - PLUG RECEPTACLE

