

## COLEMAN

**MODEL NUMBER:**

Standing Pilot Models: 7956, 7966, 7970, 7975, 7995  
Automatic Ignition Models: 7966, 7975, 7995

**BTU SIZES:**

56,000 - 66,000 - 70,000 - 75,000 - 95,000

### ACCESSIBILITY CLEARANCE

A minimum of 24 inches should be provided in front of the furnace for access to the heating elements and controls. This access may be provided by a closet door or by locating the furnace 24 inches from the facing wall or partition.

### CLEARANCE FROM COMBUSTIBLE MATERIAL

For mobile homes or recreational vehicles: Design certified for following minimum clearance from combustible material in alcove or closet installation: Back 0 in., Sides 0 in., Front (closet) 6 in., Top 2 in., Duct 0 in.

For installation on combustible flooring: Use Coleman duct connectors 7681-602 through 7681-612.

### COLD AIR RETURN AIR DUCTS

If installed in closet, return air opening must have a minimum of 200 sq. in. free area. See Figure 3. For clearances less than 6" from front of furnace see Figure 4.

### GARAGE

Not for installation in a garage.

### GENERAL

For natural gas operation, the furnace is designed for 7" w.c. inlet gas pressure. Pressure to main burner is then reduced to 3 1/2" w.c.

For L.P. gas operation, pressure measured at the gas valve must be 11" w.c.

When converting valve from or to LP gas use, it will be necessary to change main burner orifice to prevent an underfired or overfired condition. See furnace nameplate for complete instructions.

HIGH ALTITUDE INSTALLATIONS

Deration

For elevation above 2,000 feet, derate the furnace 4% for each 1,000 feet of elevation above sea level.

MOBILE HOME

Certified for installation in a mobile home.

VENTING MATERIAL AND REQUIREMENTS

Factory roof jack for venting and combustion air are required.

VENT CLEARANCE FROM COMBUSTIBLE MATERIAL

VENTING PROCEDURE

See enclosed examples for venting procedure.

MISCELLANEOUS INFORMATION/NOTES

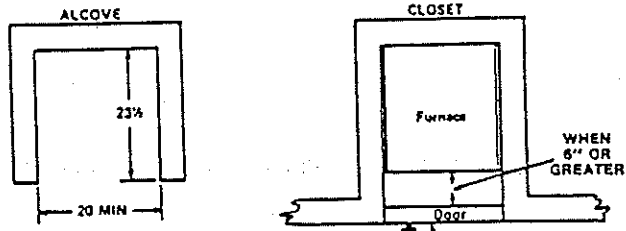

When installed in a closet with 6" or greater of front door clearance, the closet door return air opening must have a minimum free area of 200 square inches.

Figure 3

For furnace front door clearances of 0" to less than 6" from closet door.

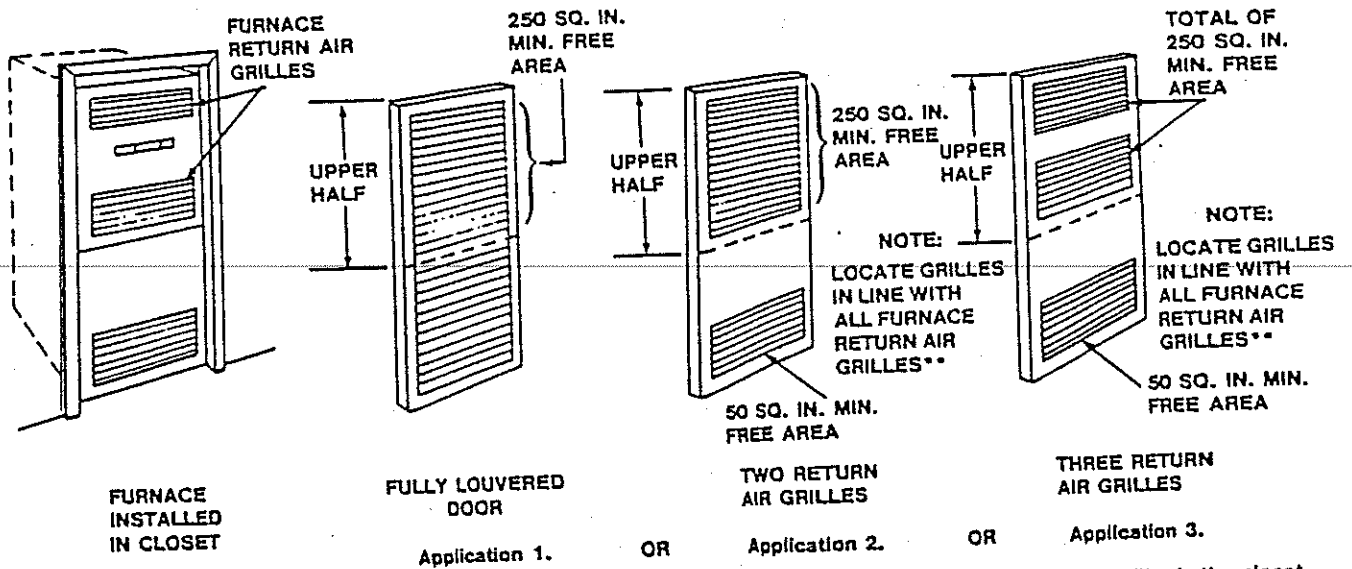

\*\*When the furnace front door clearance is greater than 1" but less than 6" to the closet door, the return air grilles in the closet door need not line up directly opposite the return air grilles in the furnace door.

Figure 4

Coleman

**Blend-Air™**

Environmental  
System

DELUXE  
MODELS

TECHNICAL  
SPECIFICATIONS

MODELS:

For Gas Furnace: 7681A6501 Basic Unit w/7681-8511 Deluxe Damper and Controls  
For Electric Furnace: 3400A6601 Basic Unit w/3400-8511 Deluxe Damper & Controls

FEATURES:

- \* Fresh air into the ceiling cavity and into the home.
- \* Designed and U.L. approved for Coleman furnaces.
- \* Easy to install with plug-in wiring. Wiring does not require an additional electrical circuit.
- \* Exceeds federal standards requiring option ventilation.
- \* Centrifugal blower.
- \* Fresh air introduced is distributed throughout the home via the central duct system.
- \* An automatic damper prevents energy loss from home.
- \* Designed for automatic year round operation in all climatic conditions.
- \* Rugged construction for reliable, trouble-free operation.

PRINCIPLE OF OPERATION:

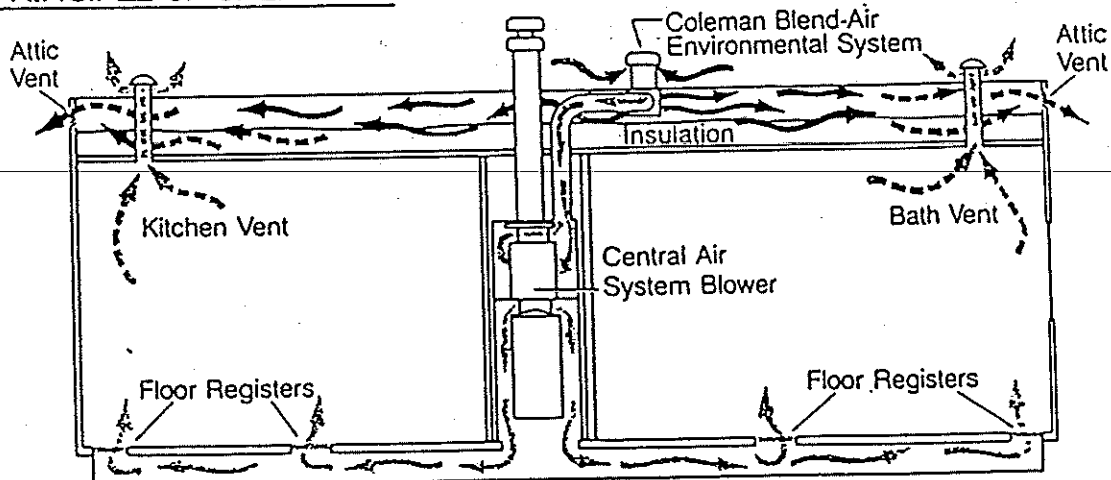

- ← Fresh air introduced into roof cavity by the Coleman Blend-Air Environmental System.
- ← Fresh air introduced into the home via the central air system.
- ← Humid air leaving attic due to pressurization effect.
- ← Stale, humid air and odors leaving home due to pressurization effect.

There are several reasons that make the Blend-Air™ System technically unique and effective in reducing moisture problems and improving indoor air quality.

(1) Propeller type attic vent fans are inherently ineffective in moving air under high static pressure conditions. A centrifugal blower can overcome this resistance and distribute air in insulation packed and tight ceiling cavities.

(2) The Blend-Air™ System creates a positive pressure in the ceiling cavity inhibiting migration of moisture from the living area. Systems that exhaust the air or communicate between the living and roof area by vents create a negative pressure and enhance the migration of air into the ceiling cavity.

During the furnace operation fresh air is injected into the living area again causing a slightly positive pressure causing natural exfiltration of stale air.

## GAS CONTROL VALVE

The gas valve is multi-function, with two operating valves in line, pressure regulator and manual gas cock. See Figures 6 and 7.

The pressure regulator is factory set to provide an operating manifold pressure of 3.5" W.C. on models equipped for Natural gas and 10" W.C. on models equipped for LP gas.

The pressure regulator is a limited adjustment type. Refer to the section titled "Minor Input Adjustment" under "Furnace Input Capacity".

## LIGHTING INSTRUCTIONS

This furnace is equipped with an automatic electric spark, direct burner ignition system which lights main burners each time the thermostat calls for heat.

This furnace cannot be lighted with a match.

## WARNING

**FAILURE TO FOLLOW THESE INSTRUCTIONS MAY RESULT IN AN EXPLOSION AND POSSIBLE DAMAGE TO THE FURNACE AND INJURY TO THE OPERATOR.**

1. Set room thermostat to lowest setting — or "off".
2. Turn knob on gas control valve to "off". The White Rodgers gas valve has a built in stop which prevents the knob from being turned directly to OFF. At this stop the knob must be depressed and then turned to OFF. See figure 6.

**WAIT 5 MINUTES.**

4. Turn knob on gas control valve to "on".
5. Set room thermostat to desired setting, above room temperature, burner will light — which may take 20-40 seconds.
6. If after 3 trials for ignition, and burner fails to light, go to complete shutdown and determine cause for failure

to light. Be sure gas supply to furnace is on and supply piping has been purged of air. Be sure electric power to furnace is on.

7. For complete shutdown — set thermostat to lowest setting, or "off" and turn knob on gas control valve to "off".

## BURNER ADJUSTMENT

After lighting the furnace, allow the furnace to operate for approximately 15 minutes and then adjust burner primary air as follows:

1. Loosen air adjustment rod locking screw. See figure 8.

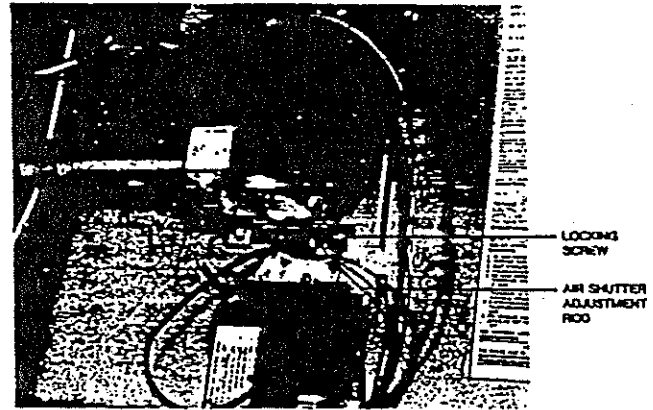

Figure 8

2. Close primary air shutter by pulling on adjustment rod until yellow tips appear in the flame at the end of the burner. See figure 9.
3. Slowly open the primary air shutter by pushing adjustment rod in until yellow flame tips at the end of the burner disappear, then push adjustment rod in another 1/8 inch.
4. Secure primary air adjustment rod by tightening locking screw against it.

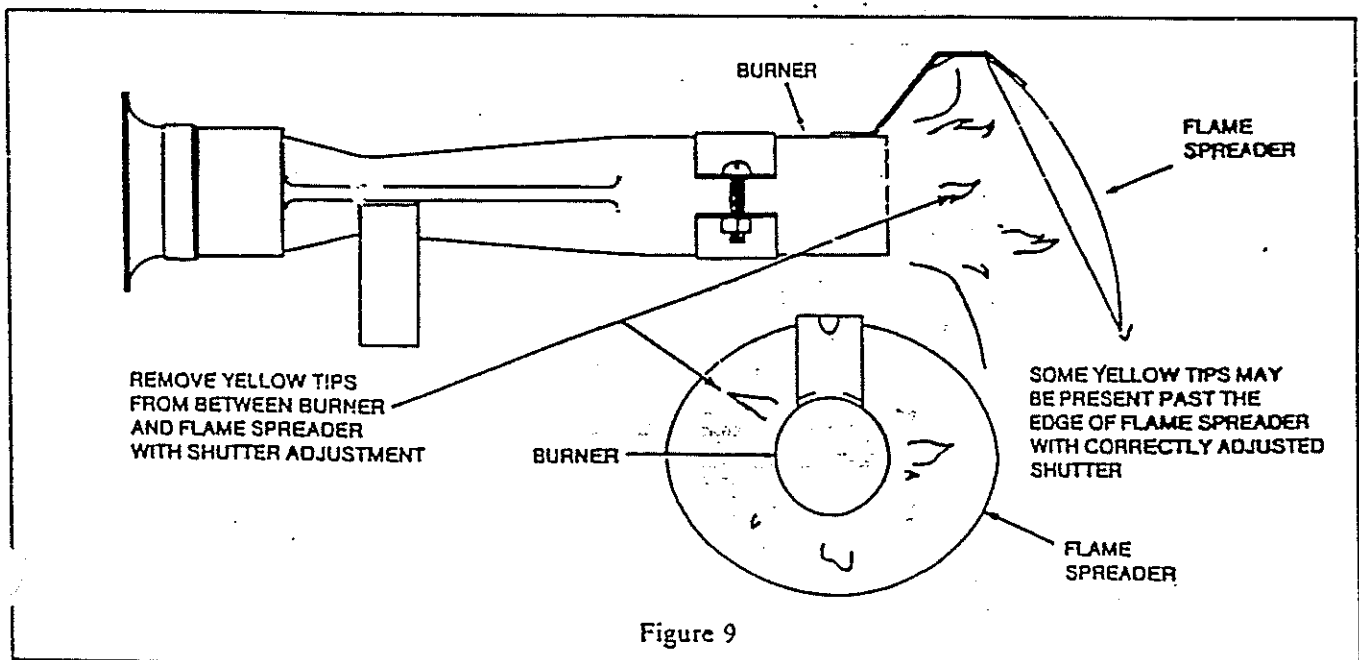
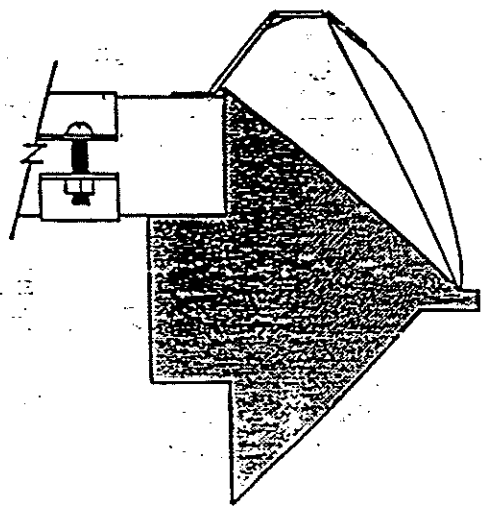
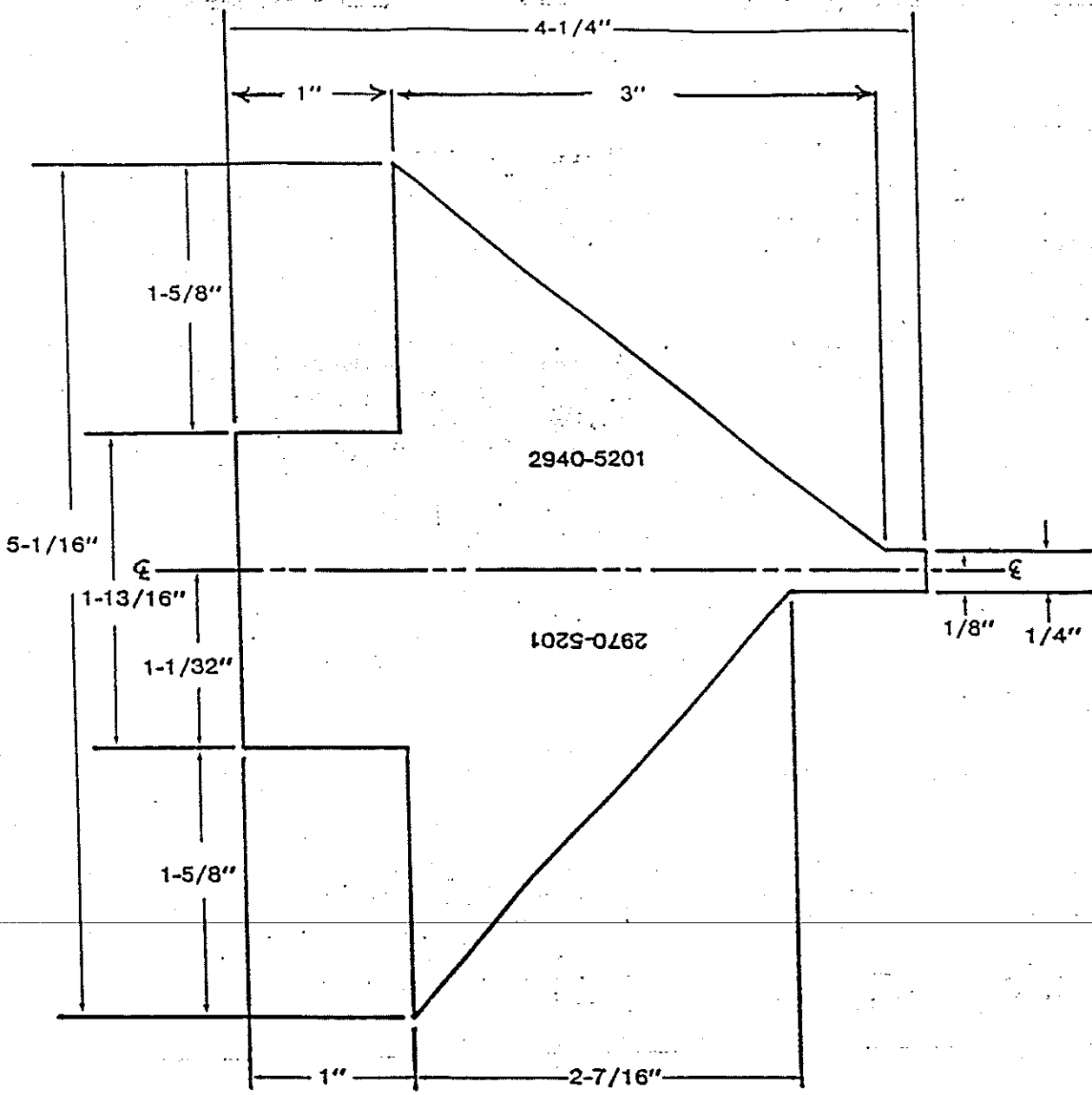

Figure 9



# **Evcon INDUSTRIES, INC.**

**IMPORTANT  
CONSUMER INFORMATION BULLETIN  
AFTER COMPLIANCE WITH THIS BULLETIN, PLACE THESE  
INSTRUCTIONS IN YOUR OWNERS INFORMATION MANUAL ON PAGE #5**

Dear Evcon Customer:

Thank you for your recent purchase of a home equipped with a quality Coleman® Evcon AutoPilot Gas Furnace. Although it is designed to heat your home reliably and comfortably for many years, we have received reports that in a few instances these furnaces have experienced interrupted ignition, which adversely affects performance. In order to insure that this does not occur to your furnace, please do the following:

1. Using the illustration on the reverse side of this letter, as a guide, go to the gas furnace and turn off the ignition module switch and leave it off.
2. Affix the enclosed yellow instruction sticker to the furnace, over the existing orange colored lighting instructions, as shown in step #4 on the reverse side of this letter.
3. Affix the small sticker (step #14) below step #13 on the lighting instruction sheet as shown in step #5 on the reverse side of this letter.
4. After completing, place this instruction package on page #5 in your owners information manual.

Your furnace will continue to operate safely and reliably with the ignition module switch left permanently in the "OFF" position. If the pilot light should go out, please follow the relight instructions on the new sticker provided. If you experience repeated pilot outages, or if you have any questions about the operation of your furnace, please call 1-800-707-3658.

Thank you for your cooperation.

# INSTRUCTIONS TO TURN OFF IGNITION MODULE SWITCH & PLACEMENT OF NEW LIGHTING INSTRUCTIONS

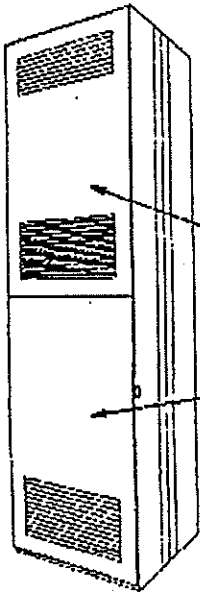

**1**

Remove Upper Door Panel

**2**

Remove Lower Door Panel

**3**

Turn Ignition Module Switch to OFF

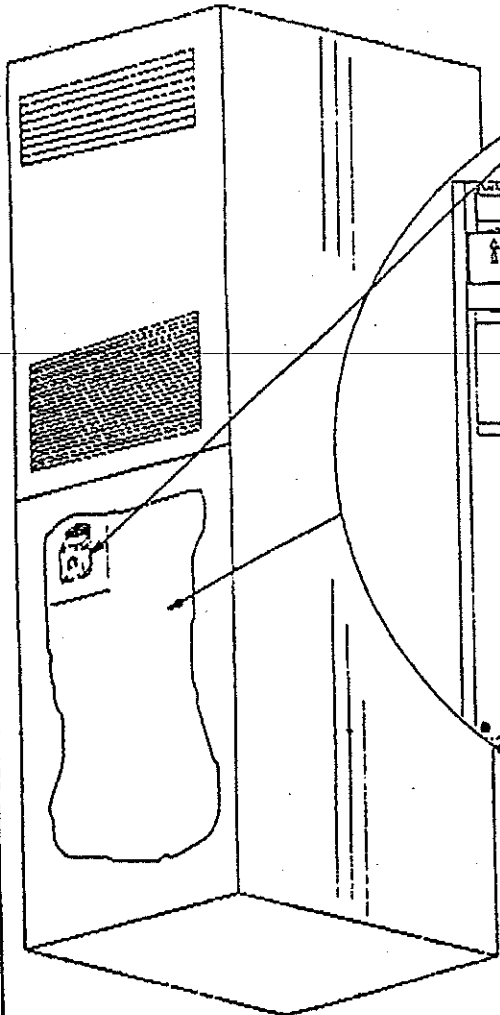

**4**

Place New Lighting  
Instruction Sticker  
over old one.

ATTENTION!

**5**

Place small sticker (Step # 14)  
below step 13 of Lighting  
Instruction Sheet, Located on  
Inside of Lower Door Panel.

**6**

Put Door Panels On

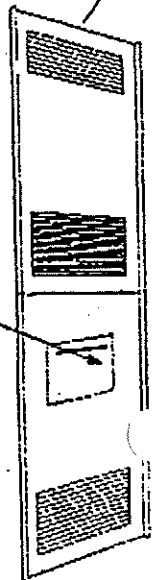



# INSTALLATION INSTRUCTIONS

## ROOF JACKS FOR PRESIDENTIAL® II FURNACES WARNING

1. The roof jack as determined from the appropriate charts below must be applied.
2. The inner flue pipe must be present.
3. The inner flue tube and outer combustion air tube must be attached to the top of the furnace with sheet metal screws.
4. The roof jack flange and bead must extend below the finished ceiling.  
Improper installation may damage the equipment, can create a hazard and will void the warranty. CAREFULLY FOLLOW ALL INSTRUCTIONS AND WARNINGS IN THIS BOOKLET TO AVOID FIRE, EXPLOSION or ASPHYXIATION.

### OLD VENT SYSTEM

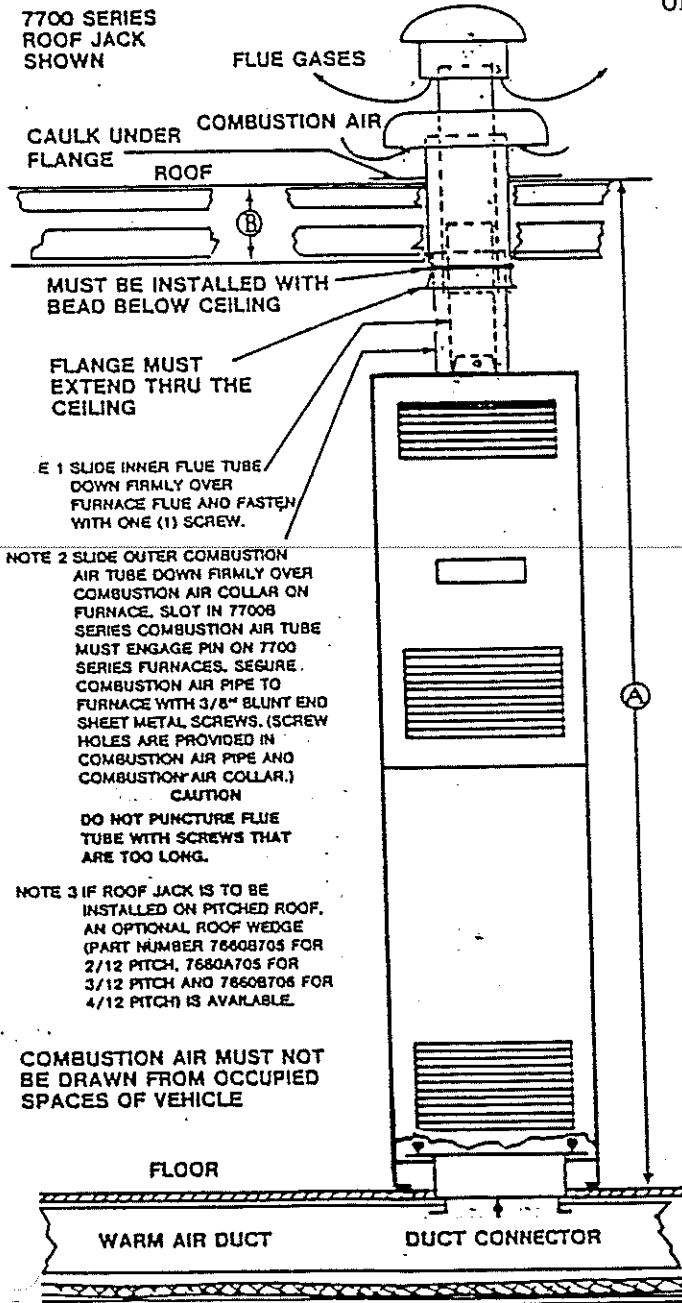

ROOF JACK MODEL	(A) ADJUSTABLE HEIGHT	(B) ROOF CAVITY
7700B7101	89" to 97"	6-3/4"
7700B7141	91" to 97"	9"
7700B7161	92" to 100"	9-3/4"
7700B7121	95" to 110"	13"
7700B7171	98" to 113"	16"
7700B8111	103" to 116"	20"
7700B8121	108" to 122"	25-5/8"
7700B7181	113" to 127"	30-5/8"
7700B8131	121" to 135"	38-5/8"

Roof jacks with removable crowns are available for special installations.

ROOF JACK MODEL	(A) ADJUSTABLE HEIGHT	(B) ROOF CAVITY
7700B8311	103" to 116"	20"
7700B8321	108" to 122"	25-5/8"
7700B7381	113" to 127"	30-5/8"
7700B8331	121" to 135"	38-5/8"
7700B8341	135" to 150"	53-5/8"

The "A" series roof jacks are also certified for use with these furnaces.

# INSTALLATION INSTRUCTIONS

## 7900 SERIES "ONE STEP" ROOF JACKS

TABLE 3

ROOF JACK MODEL NUMBER	INSTALLATION DIMENSIONS	
	Ⓐ ADJUSTABLE HEIGHT	These dimensions are from floor to top side of roof or, if used, top side of roof jack wedge. See figure A
7900-7101	89" to 97"	
7900-7121	93" to 104"	
7900-7141	101" to 122"	
7900-7151	108" to 134"	
7900-7171	145" to 175"	
7900-8161ⓐ	103" to 119"	
7900-8181ⓐ	117" to 149"	

ⓐ These jacks have removable crowns.

### WARNING

1. The roof jack as determined from the appropriate chart must be used.
2. The inner flue pipe must be present.
3. The outer combustion air tube must be attached to the top of the furnace with sheet metal screws.
4. Improper installation may damage the equipment, can create a hazard, and will void the warranty. **CAREFULLY FOLLOW ALL INSTRUCTIONS AND WARNINGS IN THIS BOOKLET TO AVOID FIRE, EXPLOSION, OR ASPHYXIATION.**

### NEW VENT SYSTEM

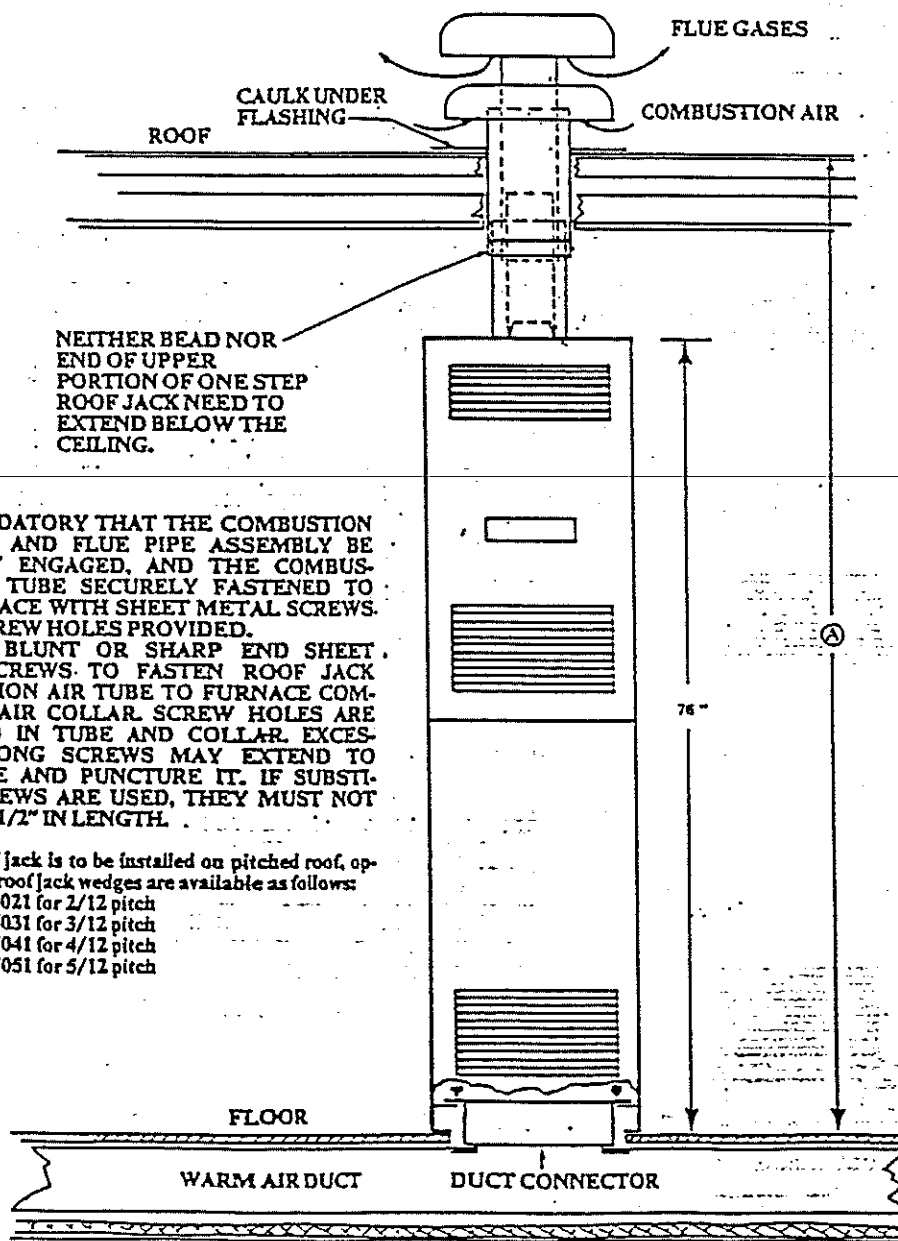

1. IT IS MANDATORY THAT THE COMBUSTION AIR TUBE AND FLUE PIPE ASSEMBLY BE PROPERLY ENGAGED, AND THE COMBUSTION AIR TUBE SECURELY FASTENED TO THE FURNACE WITH SHEET METAL SCREWS IN THE SCREW HOLES PROVIDED.
2. USE 1/2" BLUNT OR SHARP END SHEET METAL SCREWS TO FASTEN ROOF JACK COMBUSTION AIR TUBE TO FURNACE COMBUSTION AIR COLLAR. SCREW HOLES ARE PROVIDED IN TUBE AND COLLAR. EXCESSIVELY LONG SCREWS MAY EXTEND TO FLUE PIPE AND PUNCTURE IT. IF SUBSTITUTE SCREWS ARE USED, THEY MUST NOT EXCEED 1-1/2" IN LENGTH.

**NOTE:** If roof jack is to be installed on pitched roof, optional roof jack wedges are available as follows:  
 7900-7021 for 2/12 pitch  
 7900-7031 for 3/12 pitch  
 7900-7041 for 4/12 pitch  
 7900-7051 for 5/12 pitch

### CAUTION

Do not exceed the maximum height as determined from Table 3. These maximum heights allow an additional 1-1/2" travel before the flue pipe assembly is fully extended against the built-in stop. This provides an additional safeguard against the flue assembly being pulled from the roof jack due to upward movement which may occur when home is being transported or subjected to other stress conditions.

Failure to follow these instructions may result in fire, or explosion, or asphyxiation.

Figure A

# INSTALLATION INSTRUCTIONS

- a. Check to be certain that the flue pipe and combustion air tube are present.
- b. Pull the telescoping flue tube and combustion air tube assembly down from the roof jack. Slide the flue tube/combustion air tube assembly down firmly over the furnace flue outlet and combustion air collar. Fasten the combustion air tube to the furnace combustion air collar using two (2) 1/2 inch sheet metal screws. (Screw holes are provided in combustion air tube and furnace combustion air collar.) See Fig. 8 and 9.

## CAUTION

If excessively long screws are used to secure the combustion air tube to the furnace combustion air collar, they may extend through the combustion air tube to deform or puncture the furnace flue collar.

If substitute screws are used on the 7900 series roof jack, they must not exceed one and one-half inches (1-1/2") in length.

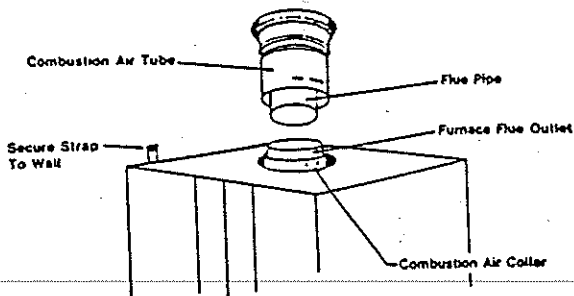

Figure 8

It is mandatory that the combustion air and flue tube assembly be properly engaged, and combustion air tube securely fastened to the furnace with sheet metal screws in the screw holes provided.

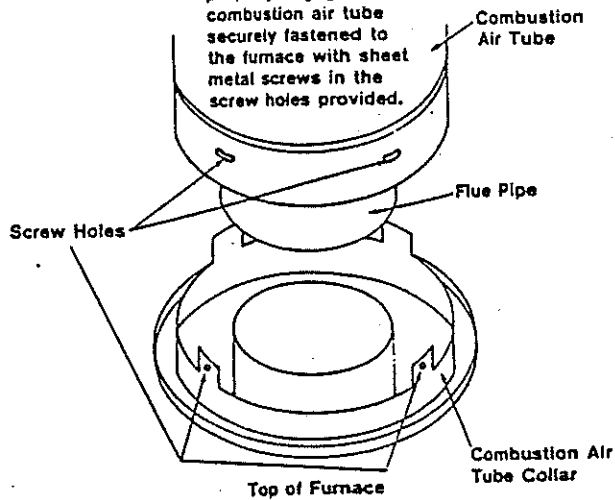
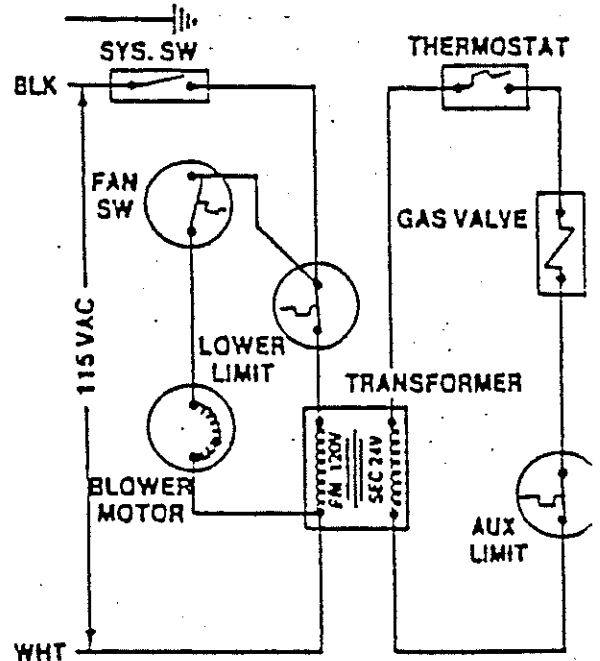
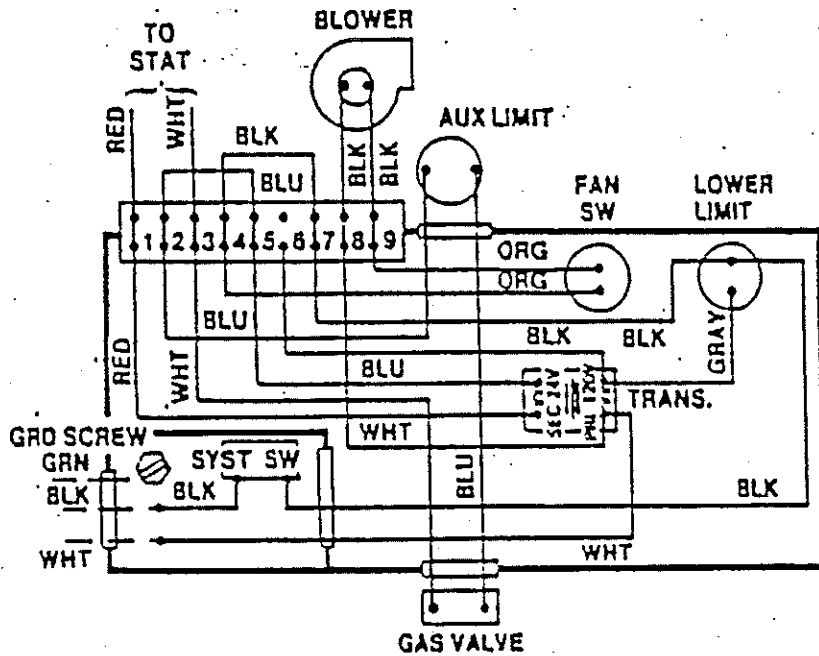

Figure 9

# 1. Standing Pilot Models

## 7900 SERIES STANDING PILOT MODELS (EXCEPT 7995)



**DANGER-SHOCK HAZARD**  
ELECTRIC POWER MUST BE TURNED OFF BEFORE  
REMOVING WIRING BOX COVER

The Coleman Company, Inc.

1972-462 (4-84) P.L.

WICHITA KANSAS 67201

### WARNING

1. THE ROOF JACK AS DETERMINED FROM THE CHART BELOW MUST BE APPLIED.
2. THE INNER FLUE PIPE MUST BE PRESENT.
3. THE INNER FLUE PIPE AND OUTER COMBUSTION AIR PIPE MUST BE ATTACHED TO THE FURNACE WITH SHEET METAL SCREWS.
4. THE ROOF JACK CROWN MUST BE PROPERLY IN PLACE.

IMPROPER INSTALLATION MAY DAMAGE THE EQUIPMENT, CAN CREATE A HAZARD AND WILL VOID THE WARRANTY. CAREFULLY FOLLOW ALL INSTRUCTIONS AND WARNINGS PROVIDED WITH THE FURNACE TO AVOID FIRE, EXPLOSION OR ASPHYXIATION.

#### COLEMAN APPROVED ROOF JACKS

ROOF JACK MODEL NUMBER	FLOOR TO ROOF HEIGHT (INCHES)
7900-7101	89 TO 97
7900-7121	93 TO 104
7900-7141	101 TO 122
7900-7151	108 TO 134
7900-7171	145 TO 175
7900-8161	103 TO 119
7900-8181	117 TO 147

### IMPORTANT

TRANSFORMER FOR HEATING ONLY. NOT RATED FOR AIR CONDITIONING. A COLEMAN AIR CONDITIONING CONTROL BOX MUST BE INSTALLED FOR PROPER TRANSFORMER SIZING.

AIR SHUTTER ADJUSTMENT - TO OPEN: PUSH ROD IN. TO CLOSE: PULL ROD OUT

# 7995 STANDING PILOT MODEL

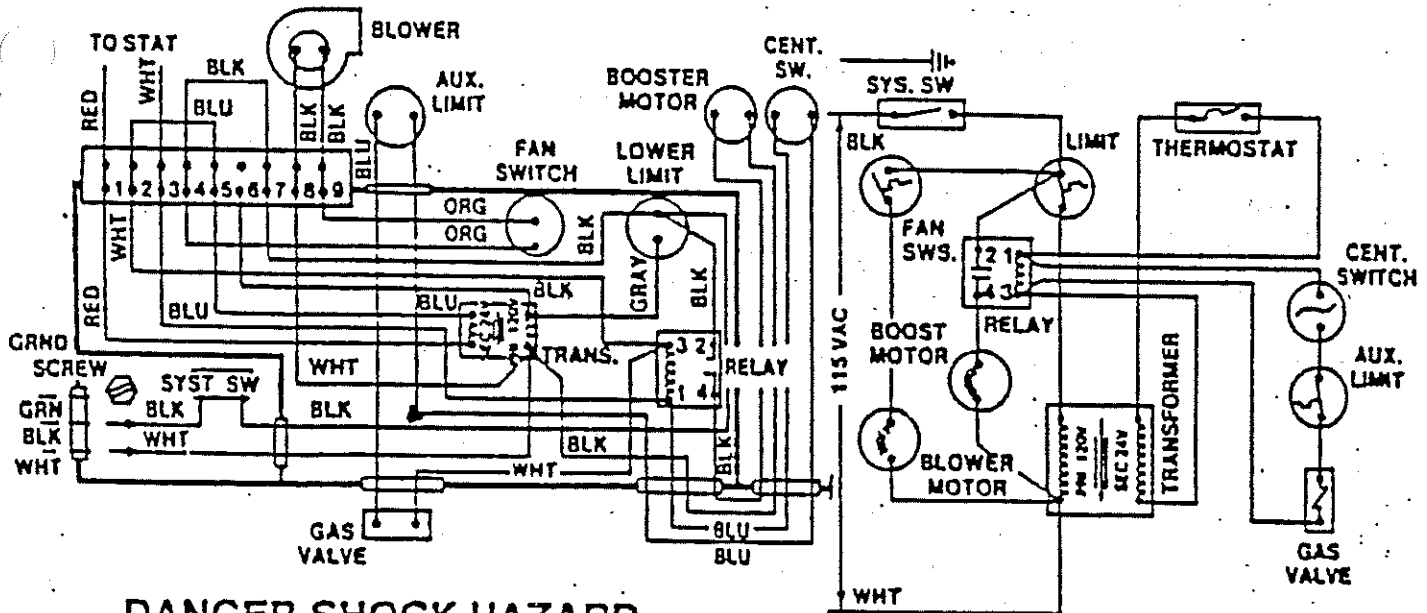

**DANGER-SHOCK HAZARD**  
ELECTRIC POWER MUST BE TURNED OFF BEFORE  
REMOVING WIRING BOX COVER

**The Coleman Company, Inc.**  
WICHITA, KANSAS 67201

1972A443 (8-84) P.1.

## WARNING

1. THE ROOF JACK AS DETERMINED FROM THE CHART BELOW MUST BE APPLIED.
2. THE INNER FLUE PIPE MUST BE PRESENT.
3. THE INNER FLUE PIPE AND OUTER COMBUSTION AIR PIPE MUST BE ATTACHED TO THE FURNACE WITH SHEET METAL SCREWS.
4. THE ROOF JACK CROWN MUST BE PROPERLY IN PLACE.

IMPROPER INSTALLATION MAY DAMAGE THE EQUIPMENT, CAN CREATE A HAZARD AND WILL VOID THE WARRANTY. CAREFULLY FOLLOW ALL INSTRUCTIONS AND WARNINGS PROVIDED WITH THE FURNACE TO AVOID FIRE, EXPLOSION OR ASPHYXIATION.

### COLEMAN APPROVED ROOF JACKS

ROOF JACK MODEL NUMBER	FLOOR TO ROOF HEIGHT (INCHES)
7900-7101	89 TO 97
7900-7121	93 TO 104
7900-7141	101 TO 122
7900-7151	108 TO 134
7900-7171	145 TO 175
7900-8161	103 TO 119
7900-8181	117 TO 147

## IMPORTANT

TRANSFORMER FOR HEATING ONLY. NOT RATED FOR AIR CONDITIONING. A COLEMAN AIR CONDITIONING CONTROL BOX MUST BE INSTALLED FOR PROPER TRANSFORMER SIZING.

AIR SHUTTER ADJUSTMENT - TO OPEN: PUSH ROD IN, TO CLOSE: PULL ROD OUT

# 7900 SERIES AUTOMATIC IGNITION MODELS

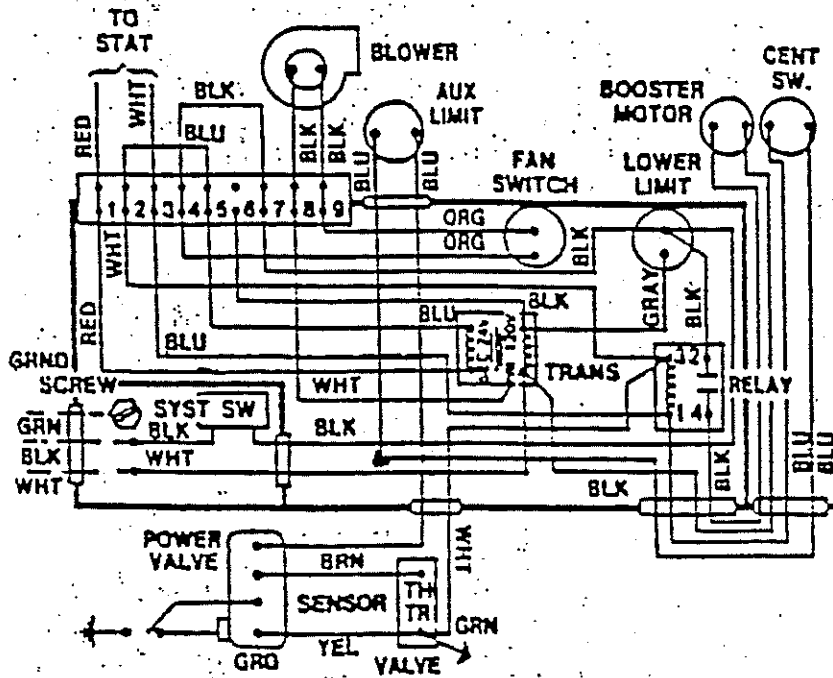

**DANGER-SHOCK HAZARD**  
 ELECTRIC POWER MUST BE TURNED OFF BEFORE  
 REMOVING WIRING BOX COVER

1972-448 (4-84) P.1.

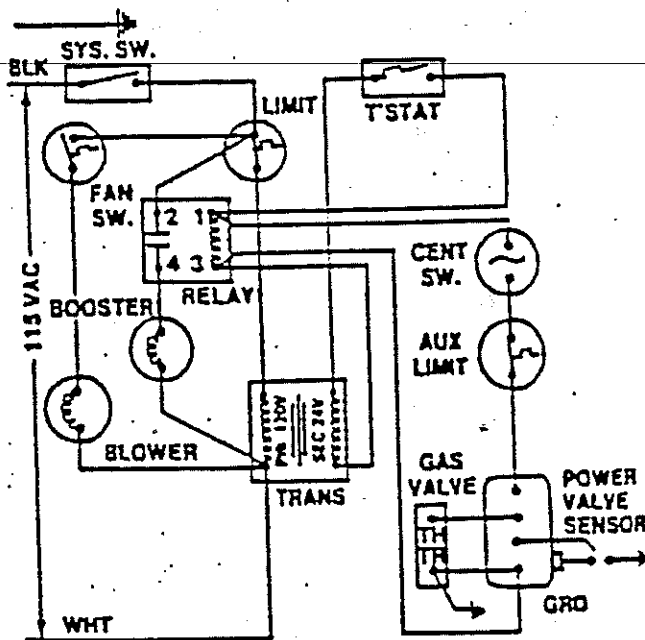

**The Coleman Company, Inc.**

WICHITA, KANSAS 67201