

GOODMAN / JANITROL DEPENDABLE NINETY TWO

MODEL NUMBER:

GSU

BTU SIZES:

60,000 - 80,000 - 100,000

ACCESSIBILITY CLEARANCE

If horizontal in attic, standard clearance required.
Recommended front clearance of 24" for servicing.

CLEARANCE FROM COMBUSTIBLE MATERIAL

Minimum clearances to combustible material

Vent = 0"

Front = 3"

Right Side = 1"

Left Side = 1"

Rear = 0"

Top of Plenum = 1"

A gas furnace must not be installed directly on carpeting, tile, or other combustible materials other than wood flooring.

COLD AIR RETURN AIR DUCTS

CAUTION: Do not take return air from bathroom, kitchens, furnace rooms, garages, utility or laundry rooms or cold areas. Do not take return air from areas where it can pick-up objectionable odors, fumes, or flammable vapors.

GARAGE

A gas fired furnace for installation in a residential garage must be installed so that the ignition source and burners are located not less than eighteen inches (18") above the floor and is protected or located to prevent physical damage by vehicles.

GENERAL

WARNING: This furnace was equipped at the factory for use with natural gas only. L.P. conversion, if required, must be performed by a qualified technician familiar with performing this type of conversion. If L.P. conversion is required, all instructions included with the factory authorized kit must be followed. The only kit that should be used for this conversion is the factory authorized LPM-03.

This furnace is designed to be installed indoors only. **Do Not install outdoors.**

continued...

GENERAL

Important Notice: A solid base plate is supplied with this furnace and must be left in place when the furnace is installed with side return ducts.

| <u>Unit Model No.</u> | <u>Vent Diameter Inches</u> | <u>Combustion Air</u> |
|-----------------------|-----------------------------|-----------------------|
| GSU060-3 | 2" | 2" |
| GSU080-4 | 2" | 3" |
| GSU100-4 | 3" | 3" |

HIGH ALTITUDE INSTALLATIONS

| | |
|--------------------|---|
| Deration | The furnace derate is 4% for each 1,000 feet above sea level. |
| Orifice | Change only |
| Regulator Pressure | Must be between 3.2" w.c. and 3.8" w.c. for natural gas. |
| Pressure Switch | Should this appliance be converted to L.P. usage refer to the instructions included in the factory authorized L.P. conversion kit (LPM-03). If for use at altitudes in excess of 2,000 feet refer to the instructions included in the factory authorized high altitude kit (HA-02). |

MOBILE HOME

DO NOT install this furnace in a mobile home.

VENTING MATERIAL AND REQUIREMENTS

| | |
|---------------|----------------------------|
| Vent Pipe | ASTM 1785, D2465 and D2266 |
| Vent Fittings | ASTM 1785, D2465 and D2266 |

PVC primer and solvent cement - ASTM D2564.
Procedure for cementing joints - ASTM D2855 (ref).

VENT CLEARANCE FROM COMBUSTIBLE MATERIAL

0" PVC pipe

VENTING PROCEDURE

The use of two 45° elbows is recommended over the use of a single 90° elbow. This appliance may be vertically or horizontally vented. It may be horizontally vented through an exterior wall.

The combustion air intake and vent termination must be located at least twelve (12) inches above expected snowfall. Consideration should be made to past unusual snow falls.

()

()

()

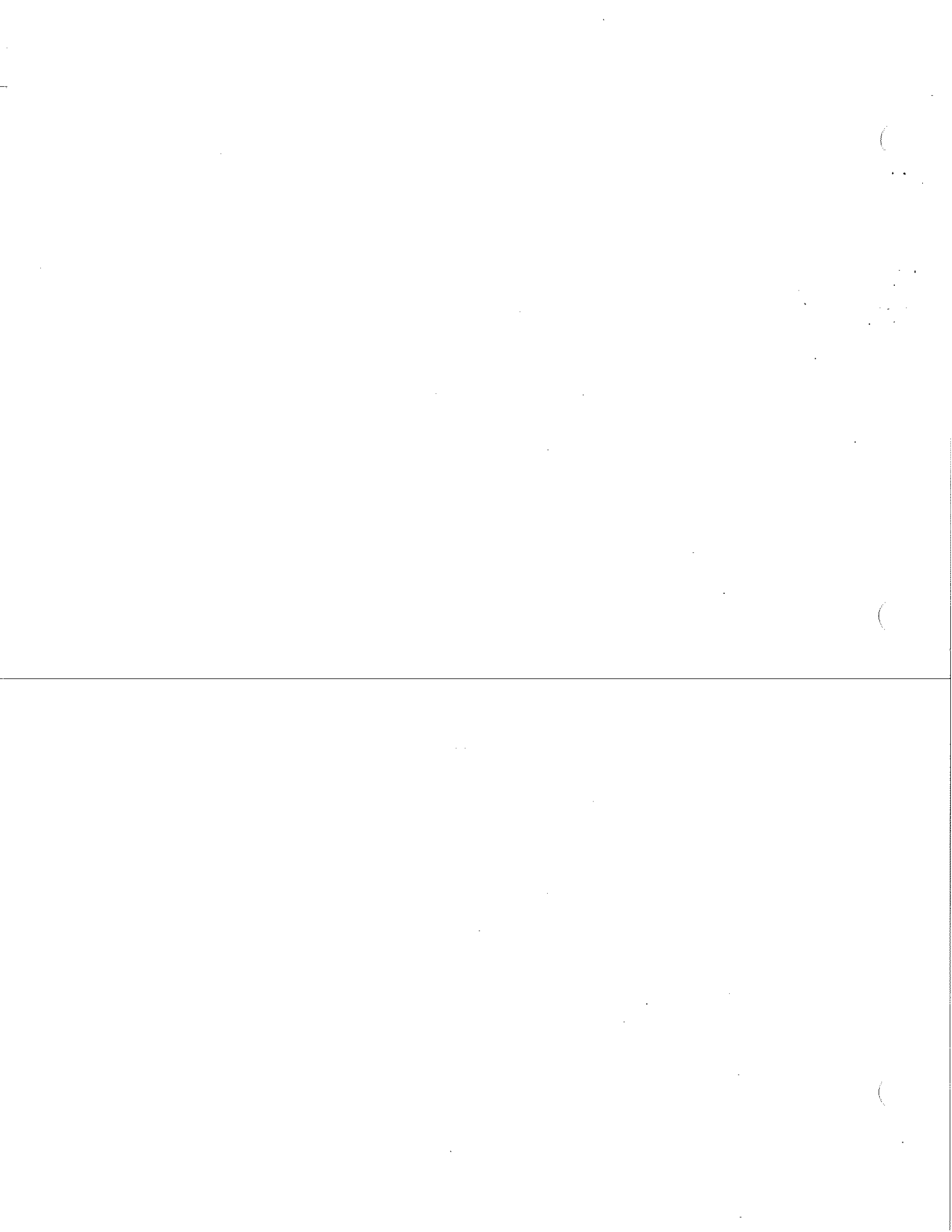

continued...

VENTING PROCEDURE

- DO NOT locate the terminal less than seven (7) feet above the public walkways. This applies to steps and stairwells as well.
- DO NOT locate the termination areas where condensate may present a problem such as flower beds, patios, etc.
- DO NOT locate within four (4) feet of a gas or electric meter or gas regulator.
- DO NOT locate the vent terminal within twelve (12) inches of an operable window.
- DO NOT locate the vent terminal less than four (4) feet below, four (4) feet horizontally from, or one (1) foot above any door, window, or gravity air inlet into any building, other than the combustion air supply pipe.
- DO NOT locate the vent terminal within three (3) feet of an inside corner of a building or structure.

SUPPORTING AND PITCHING THE VENT AND COMBUSTION AIR SUPPLY PIPE - All horizontal runs must be supported at least every five (5) feet and at joints with straps or hangers. No sags or dips are permitted. Vertical runs must be supported minimum of every six (6) feet. The combustion air supply pipe should be pitched slightly downward at the inlet to prevent water from entering the pipe.

The combustion air supply pipe must not be less than 12" from any vent outlet.

The vent length is as follows; 40 feet with a maximum of three (3) 90° elbows, excluding any required outdoor terminals. The combustion air supply pipe is the same maximum length as the vent, excluding any required outdoor terminals.

MISCELLANEOUS INFORMATION/NOTES

DO NOT install the vent pipe in the same chase with the vent from another fuel burning appliance, except with a GMN, GMPN, GMPNV or GSU.

DO NOT install the combustion air supply pipe in the same chase with another fuel burning appliance except GMN, GMPN, GMPNV, or GSU.

DO NOT install the vent pipe of the combustion air supply pipe within six (6) inches of another fuel burning appliance.

The drain trap must be easily accessible for checking and/or cleaning. It must be mounted on the furnace jacket in the holes provided.

DO NOT install the trap higher than the venter blower outlet.

DO NOT install this appliance in any area where freezing may occur without properly protecting the drain assembly.

MOTOR LUBRICATION AND MAINTENANCE

The circulating air blower is equipped with sleeve bearings which are permanently lubricated by the motor manufacturer and require no lubrication.

The venter motor has bearings which are prelubricated by the motor manufacturer and require no attention.

HEATING MODE

The room thermostat reacts to a demand for heat.

The furnace control checks for an open limit (the limits are in the normally closed position). If an open limit is detected the furnace will remain inoperable until the limit is closed. During an open limit the circulating air blower will be energized. The status light will blink four (4) times.

The control will then check to insure that the vent pressure switch is open. If, at this point, the vent pressure switch is closed the control will blink two (2) times and will remain inoperable until the situation is corrected.

Next, the venter blower is energized.

The vent pressure switch will close when it detects a pressure in excess of it's setting. If the pressure switch fails to close the status light will flash three (3) times. The sequence cannot continue until the pressure switch closes.

The flame roll-out switches are then checked to assure that they are in the closed position.

After a pre-purge of about fifteen (15) seconds the hot surface igniter will be energized.

After a warm-up period of seventeen (17) seconds the gas valve will open.

The burners will ignite and the flame sensor will detect the presence of flame. The igniter will deenergize in approximately seven (7) seconds. If the sensor does not detect flame the gas valve will close and the ignition cycle will be repeated for a total of three attempts at ignition. If, after the third attempt, the presence of flame is not detected, the furnace will go into a lockout condition for one (1) hour. It will then repeat the ignition cycle.

This one (1) hour lockout and retry will occur indefinitely.

Thirty (30) seconds after the main valve is energized the circulating air blower will be activated. The furnace will remain in operation until the demand for heat is satisfied.

Once the demand is satisfied the venter will shut off, and the circulating air blower will shut off after approximately two and one half (2 1/2) minutes.

The furnace will remain dormant until the next demand for heat.

G5U 080

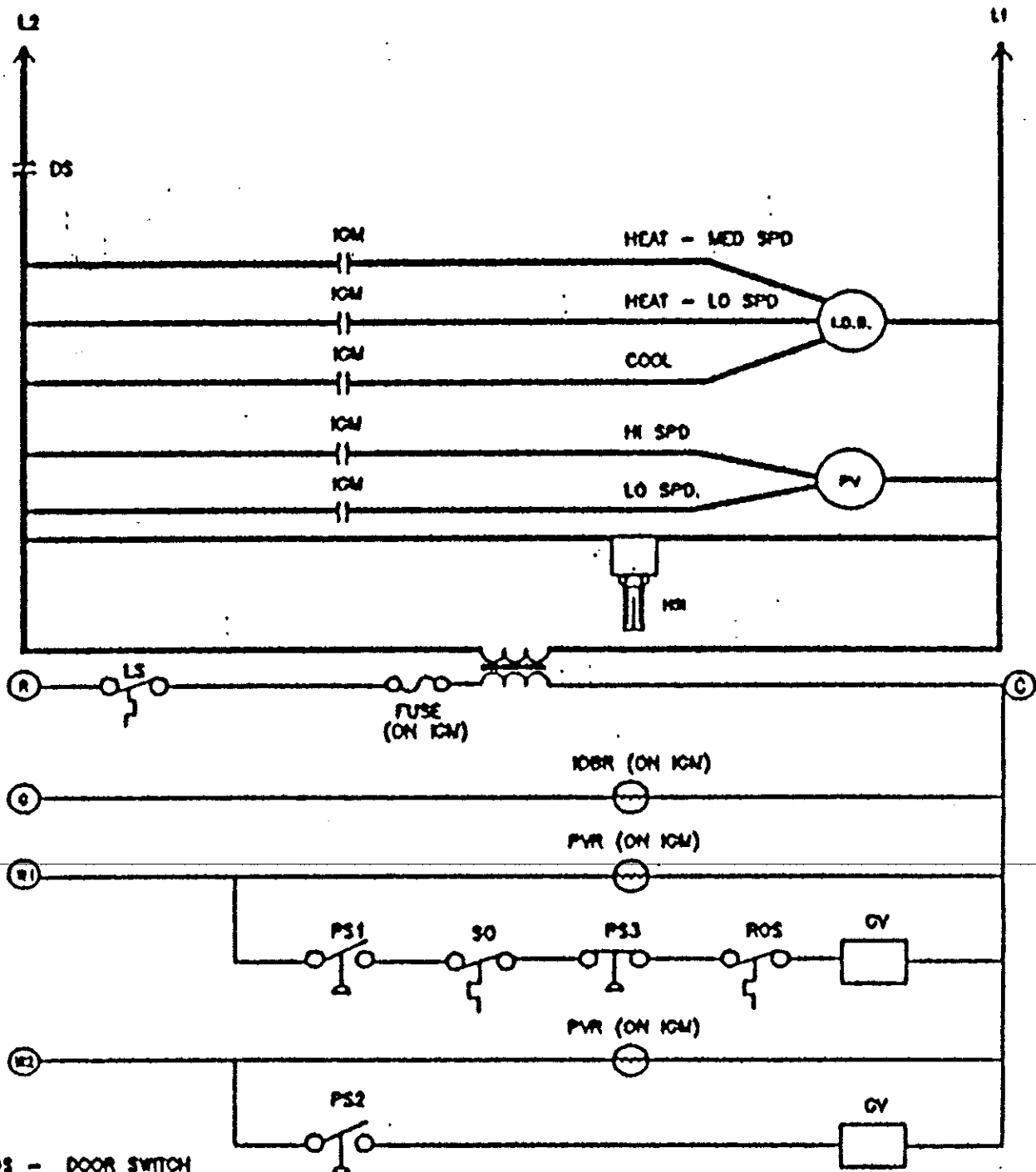

- DS - DOOR SWITCH
- FS - FLAME SENSOR
- GV - GAS VALVE
- HSI - HOT SURFACE IGNITOR
- IOB - INDOOR BLOWER
- IDBR - INDOOR BLOWER RELAY
- ICM - IGNITION MODULE
- LS - LIMIT SWITCH
- PCB - PRINTED CIRCUITE BOARD
- PSC - PRESSURE SWITCH COMB. BOX
- PS1 - PRESSURE SWITCH LO FIRE
- PS2 - PRESSURE SWITCH HI FIRE
- PV - POWER VENTOR
- PVR - POWER VENT RELAY
- ROS - ROLLOUT SWITCH
- SO - STACK OVERTEMP

WIRING CODE
 HIGH VOLTAGE ———
 LOW VOLTAGE ———

NOTES:

1. REPLACEMENT WIRE MUST BE THE SAME SIZE AND TYPE OF INSULATION AS ORIGINAL (105°C)
2. WARNING CABINET MUST BE PERMANENTLY GROUNDED TO CONFORM TO N.E.C. & LOCAL CODES.
3. THE LEADS FROM THE MOTOR MAY BE CHANGED TO THE REQUIRED SPEED.
 •MED-HIGH - YELLOW
 •MED-LOW - ORANGE



(

(

(