

installation operation and service instructions

G12 AND G12E SERIES UNITS

Gas Units
502,192M
10/87
Supersedes 502,110M

FOR YOUR SAFETY

Do not store or use gasoline or other flammable vapors or liquids in the vicinity of this or any other appliance.

WARNING

Improper installation, adjustment, alteration, service, or maintenance can cause injury or property damage. Refer to this manual. For assistance or additional information, consult a qualified installer, service agency, or the gas supplier.

FOR YOUR SAFETY WHAT TO DO IF YOU SMELL GAS

- Do not try to light any appliance.
- Do not touch any electrical switch; Do not use any phone in your building.
- Immediately call your gas supplier from a neighbor's phone. Follow the gas supplier's instructions.
- If you cannot reach your gas supplier call the fire department.

TABLE OF CONTENTS

Unit Dimensions — Start-Up and Performance Check List	Page 1
Requirements — Installation	Page 2
Electrical	Page 11
Start-Up — Adjustments	Page 14
Service	Page 15
Repair Parts List — Parts Identification	Page 17

UNIT DIMENSIONS

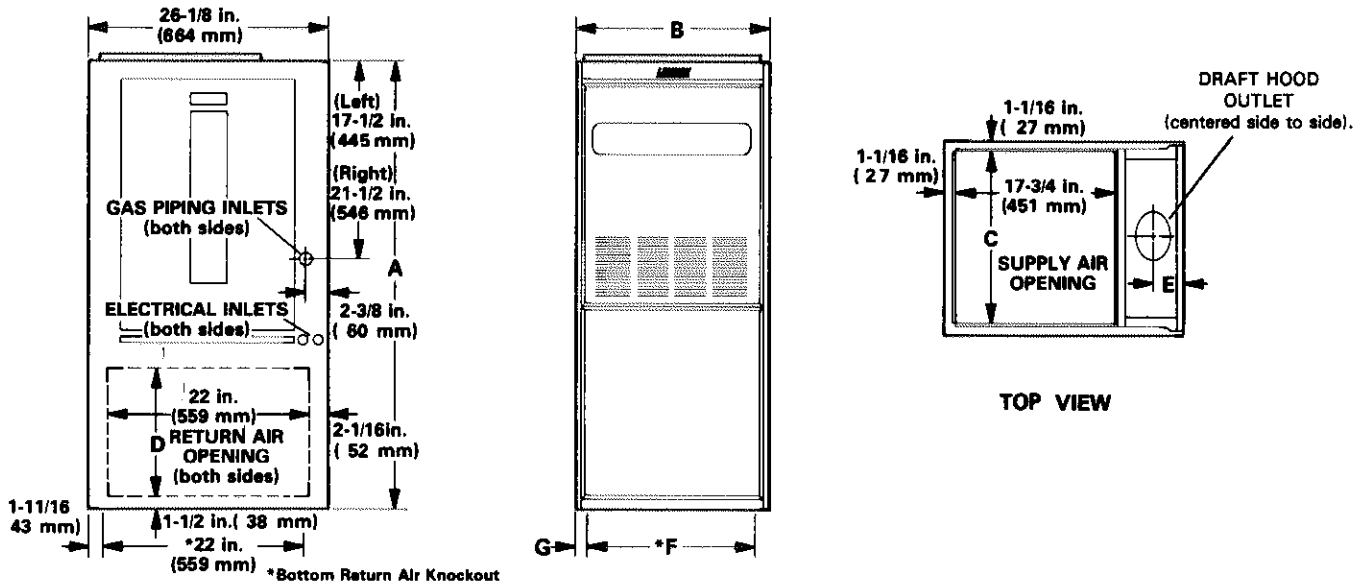

Model No.	A	B	C	D	E	F	G
28,40,55 & 82 Series	49 in. (1245mm)	16-1/4 in. (413mm)	14-1/8 in. (359mm)	14 in. (356mm)	3-1/8 in. (79 mm)	11 in. (279mm)	2-5/8 in. (67 mm)
110 Series	49 in. (1245mm)	21-1/4 in. (540mm)	19-1/8 in. (486mm)	14 in. (356mm)	3-1/8 in. (79 mm)	14 in. (356mm)	3-5/8 in. (92 mm)
137 Series	53 in. (1346mm)	26-1/4 in. (667mm)	24-1/8 in. (613mm)	18 in. (457mm)	3-3/8 in. (86 mm)	21 in. (533mm)	2-5/8 in. (67 mm)
165 & 200 Series	53 in. (1346mm)	31-1/4 in. (794mm)	29-1/8 in. (740mm)	18 in. (457mm)	3-3/8 in. (86 mm)	26 in. (660mm)	2-5/8 in. (67mm)

START-UP AND PERFORMANCE CHECK LIST

Job Name _____ Job No. _____ Date _____
 Job Location _____ City _____ State _____
 Installer _____ City _____ State _____
 Unit Model No. _____ Serial No. _____ Serviceman _____

HEATING SECTION

Electrical Connections Tight?
 Supply Voltage _____ Blower Motor Amps _____
 Blower Motor H.P. _____
 Blower Motor Lubrication O.K.?
 Gas Piping Connections Tight & Leak-Tested
 Fuel Type: Natural Gas? LP Gas?
 Furnace BTU Input _____
 Line Pressure (7" Natural Gas or 11" LP Gas) _____

Regulator Pressure (3.5 Factory Setting, Nat. Only) _____
 Air Shutters Properly Adjusted (if installed)?
 Vent Connections Tight? Proper Draft?
 Fan Control Setting (90° Factory Setting) _____
 Limit Control Cutout _____ Temperature Rise _____
 Filters Clean & Secure?
 Furnace Grounded?

THERMOSTAT

Calibrated? Heat Anticipator Properly Set? Level?

I - REQUIREMENTS

Installation of Lennox gas central furnaces must conform with local building codes or, in the absence of local codes, with the National Fuel Gas Code (ANSI-Z223.1-1984). The National Fuel Gas Code (ANSI-Z223.1-1984) is available from:

American National Standards Institute, Inc.
1430 Broadway
New York, NY 10018

These units are A.G.A. (American Gas Association) design certified.

Air supply for combustion and ventilation must conform to the methods outlined in the National Fuel Gas Code, ANSI-Z223.1-1984, section 5.3 — Air for Combustion and Ventilation — or applicable provisions of local building codes.

Furnace is certified for installation clearances to combustible material as listed on appliance rating plate and table 1.

TABLE 1

Clearances	Location	Inches (mm)
Service access	Front	36 in. (914 mm)
To combustible materials	Top, Side and Rear	1 in. (25 mm)
	Front and Flue	6 in. (152 mm)
Around combustion chamber air opening	Front	6 in. (152mm)

NOTE - Service access clearance must be maintained.

G12E-200 units are certified for alcove installation only at the clearances listed in table 2.

**TABLE 2
CLEARANCES — G12E-200 ONLY**

Clearances	Location	Inches (mm)
Service access	Front	36 in. (914mm)
To combustible materials	Top, side and rear	1 in. (25mm)
	Front	Alcove
	Flue	6 in. (152mm)
Around combustion chamber air opening	Front	Alcove

NOTE - Service access clearance must be maintained.

Vent installations shall be in accordance with part 7 — Venting of Equipment — of the National Fuel Gas Code, ANSI-Z223.1-1984, or applicable provisions of local building codes. Vent connectors serving appliances vented by natural draft shall not be connected into any portion of mechanical draft systems operating under positive pressure.

NOTE - For installation on combustible floors, appliance shall not be installed directly on carpeting, tile, or other combustible material other than wood flooring.

For installation in a residential garage, unit must be installed so that the burner(s) and the ignition source are located no less than 18 inches above the floor. The furnace must also be located or protected to avoid physical damage by vehicles.

Unit must be adjusted to obtain a temperature rise within the range specified on the appliance rating plate.

The draft hood shall be installed in the same atmospheric pressure zone as the combustion air inlet to the furnace.

When this furnace is used in conjunction with cooling units, it shall be installed in parallel with or upstream of cooling units to avoid condensation in the heating element. With a parallel flow arrangement, damper (or other means to control flow of air) shall be adequate to prevent chilled air from entering the furnace and, if manually operated, must be equipped with means to prevent operation of either unit, unless damper is in full "heat" or "cool" position.

When installed the furnace must be electrically grounded in accordance with local codes or, in the absence of local codes with the National Electric Code, ANSI/NFPA No. 70-1987, if external electrical source is used. The National Electric Code (ANSI/NFPA No. 70-1987) is available from:

National Fire Protection Association
470 Atlantic
Boston, MA 02210

Field wiring connections with unit must meet or exceed specification of type T wire and withstand a 63°F (35°C) temperature rise.

When a furnace is installed so that supply ducts carry air circulated by the furnace to areas outside the space containing the furnace, the return air shall be handled by a duct(s) sealed to the furnace casing and terminating outside the space containing the furnace.

II - GENERAL

These instructions are intended as a general guide and do not supersede local codes in any way. Authorities having jurisdiction should be consulted before installation.

SHIPPING AND PACKING LIST

- 1 - Leveling bolt package (if ordered)
- 1 - Thermostat (if ordered)
- 1 - Rubber grommet (for electrical make-up)
- 1 - Slab filter and mounting clips (G12D units only)

SHIPPING DAMAGE

Check unit for shipping damage. Receiving party should contact the last carrier immediately if any shipping damage is found.

III - INSTALLATION

SETTING EQUIPMENT

- 1 - Holes are provided in the corners of unit base for leveling unit. Install leveling bolts (if desired) as shown, or shim under unit. See figure 1.

CAUTION - If leveling bolts are used, be sure to install the plastic nuts as shown and tighten snugly before setting unit.

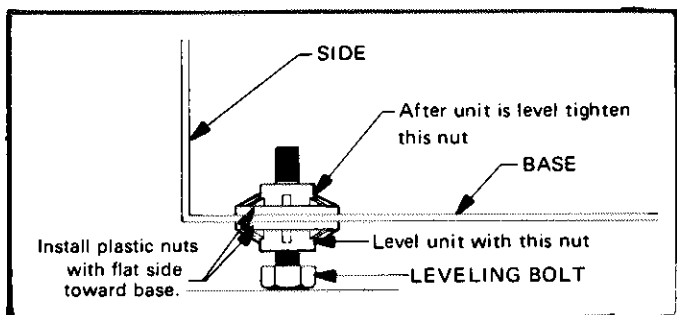

FIGURE 1

- 2 - Set unit in desired location keeping in mind clearances listed on appliance rating plate. Also keep in mind gas supply connection, electrical supply, vent connections and clearances for installing and servicing unit.

RETURN AIR OPENING

Return air can be brought in either side or at bottom of unit. Scribe lines show the outline of each return air opening.

DUCT SYSTEM

Size and install the supply and return duct system using industry-approved standards that result in a quiet and low static system with uniform air distribution.

COMBUSTION, DILUTION AND VENTILATION AIR

Until recently, there was no problem in bringing in sufficient amounts of outdoor air for combustion — infiltration provided all the air that was needed and then some. In today's homes built with energy conservation in mind, tight construction practices make it necessary to bring in air from outside for combustion. Consideration must also be given to the use of exhaust fans, appliance vents, chimneys and fireplaces because they force additional air that could be used for combustion out of the house. Unless outside air is brought into the home for combustion, negative pressure (pressure outside is greater than inside pressure) will build to the point that a down draft can occur in the furnace vent pipe or chimney. Combustion gases enter the living space creating a potentially dangerous situation.

In the absence of local codes concerning air for combustion and ventilation, this section outlines guidelines and recommends procedures for installing G12 furnaces in a manner that ensures efficient and safe operation. Special consideration must be given to combustion air needs as well as requirements for exhaust vents and running gas piping. A portion of this information has been reprinted with permission from NFPA 54, Standard for the National Fuel Gas Code, Copyright 1984, National Fire Protection Association, Quincy, Massachusetts 02269. This reprinted material is not the complete and official position of the NFPA on the referenced subject, which is represented only by the standard in its entirety.

Combustion Air Requirements

CAUTION - Insufficient combustion air can cause headaches, nausea, dizziness or asphyxiation.

All gas-fired appliances require air to be used for the combustion process. If sufficient amounts of combustion air are not available, the furnace or other appliance will operate in an inefficient and unsafe manner. Enough air must be provided to meet the needs of all fuel-burning appliances, as well as appliances such as exhaust fans which force air out of the home. When fireplaces, exhaust fans, or clothes dryers are used at the same time as the furnace, much more air is required to ensure proper combustion and to prevent a down-draft situation. Insufficient amounts of air also cause incomplete combustion which can result in carbon monoxide. The requirements for providing air for combustion and ventilation depend largely on whether the furnace is installed in an unconfined or confined space.

Unconfined Space

An unconfined space is an area such as a basement or large equipment room with a volume greater than 50 cubic feet per 1,000 Btu per hour of the combined input rating of all appliances installed in that space. This space also includes adjacent rooms which are not separated by a door. Though an area may appear to be unconfined, it might be necessary to bring in outdoor air for combustion if the structure does not provide enough air by infiltration. If the furnace is located in a building of tight construction with weather stripping and caulking around the windows and doors, follow the procedures outlined for using air from the outside for combustion and ventilation.

Confined Space

A confined space is an area with volumes less than 50 cubic feet per 1,000 Btu per hour of the combined input rating of all appliances installed in that space. This definition includes furnace closets or small equipment rooms.

When the furnace is installed so that supply ducts carry air circulated by the furnace to areas outside the space containing the furnace, the return air must be handled by ducts which are sealed to the furnace casing and which terminate outside the space containing the furnace. This is especially important when the furnace is mounted on a platform in a confined space such as a closet or small equipment room. Even a small leak around the base of the unit at the platform or at the return air duct connection can cause a potentially dangerous negative pressure condition. Air for combustion and ventilation can be brought into the confined space either from inside the building or from outside.

Air from Inside

If the confined space housing the furnace adjoins space categorized as unconfined, air can be brought in by providing two permanent openings between the two spaces. Each opening must have a minimum free area of 1 square inch per 1,000 Btu hour of the total input rating of all gas-fired equipment in the confined space. Each opening must be at least 100 square inches. One opening shall be within 12 inches of the top of the enclosure and one opening within 12 inches of the bottom. See figure 2.

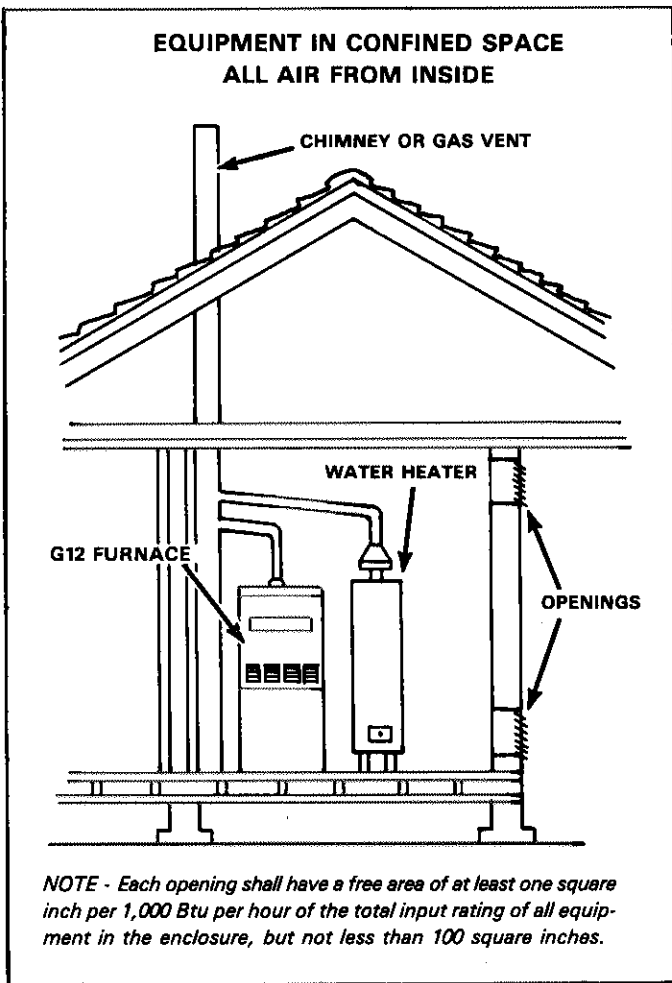

FIGURE 2

Air from Outside

If air from outside is brought in for combustion and ventilation, the confined space shall be provided with two permanent openings. One opening shall be within 12 inches of the top of the enclosure and one within 12 inches of the bottom. These openings must communicate directly or by ducts with the outdoors or spaces (crawl or attic) that freely communicate with the outdoors or indirectly through vertical ducts. Each opening shall have a minimum free area of 1 square inch per 4,000 Btu per hour of total input rating of all equipment in the enclosure (See figures 3 and 4). When communicating with the outdoors through horizontal ducts, each opening shall have a minimum free area of 1 square inch per 2,000 Btu per total input rating of all equipment in the enclosure (See figure 5).

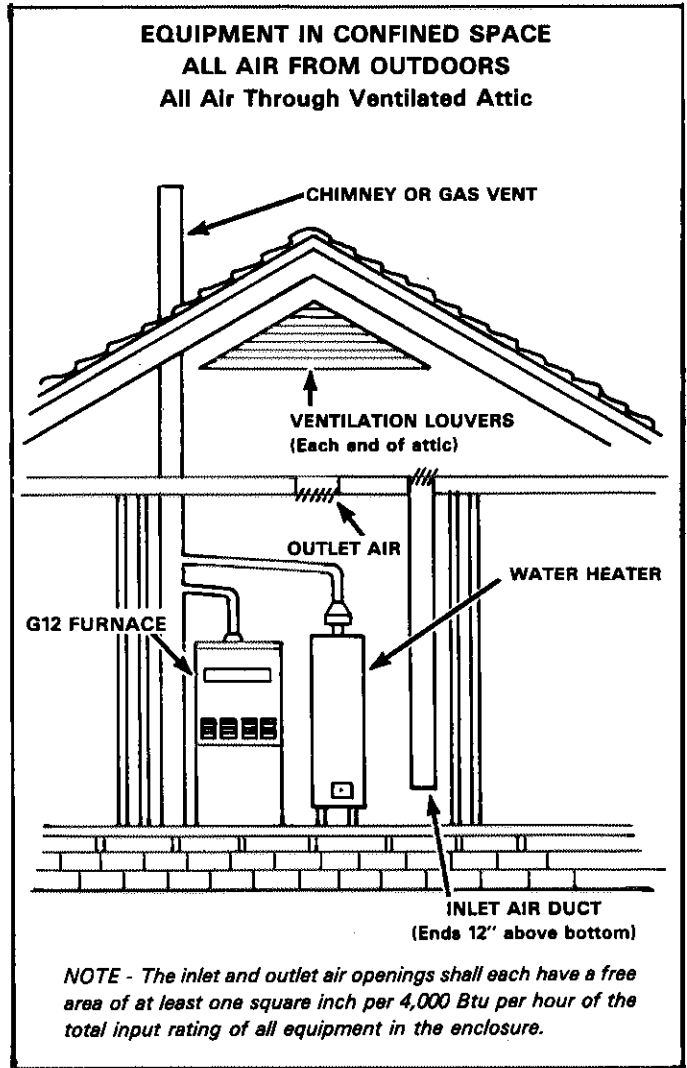

FIGURE 3

When ducts are used, they shall be of the same cross-sectional area as the free area of the openings to which they connect. The minimum dimension of rectangular air ducts shall be no less than 3 inches. In calculating free area, the blocking effect of louvers, grilles, or screens must be considered. If the design and free area of protective covering is not known for calculating the size opening required, it may be assumed that wood louvers will have 20 to 25 percent free area and metal louvers and grilles will have 60 to 75 percent free area. Louvers and grilles must be fixed in the open position or interlocked with the equipment so that they are opened automatically during equipment operation.

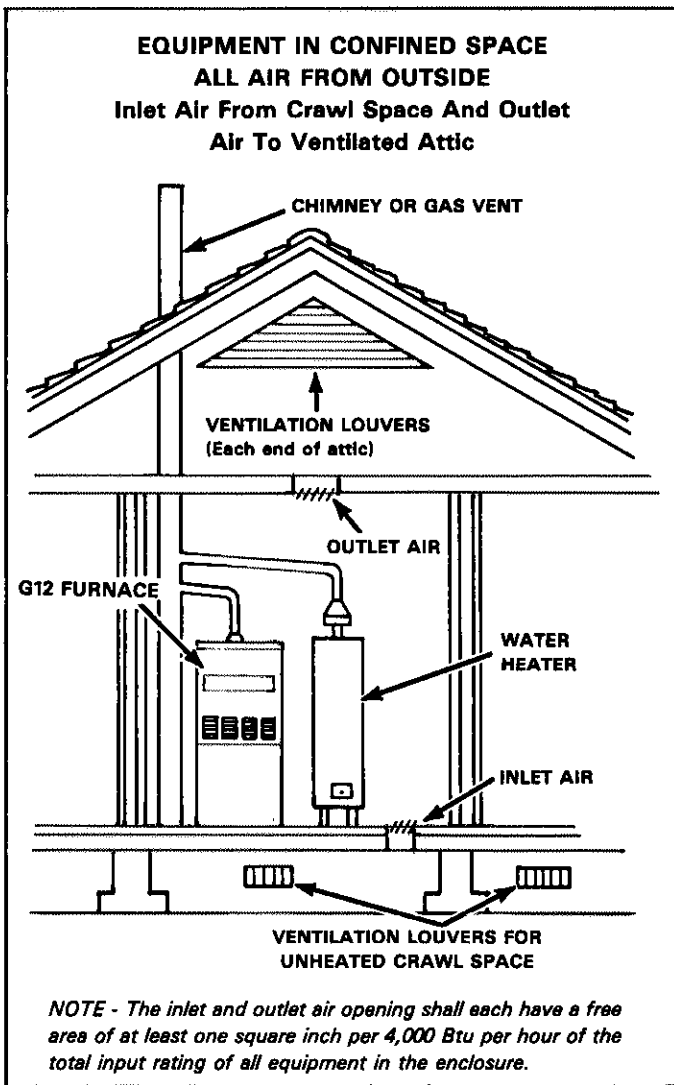

FIGURE 4

Venting Requirements

G12 and G12E gas furnaces must be vented in compliance with all local codes, the National Fuel Gas Code (ANSI-Z223.1-1984) and these instructions.

CAUTION - Improper ventilation can cause headaches, nausea, dizziness or asphyxiation.

G12 and G12E series gas furnaces must be vented in accordance with the methods outlined in these instructions. These methods require the use of NFPA or ANSI-approved chimneys or U.L.-listed type B gas vents, as well as the modifications and limitations outlined below.

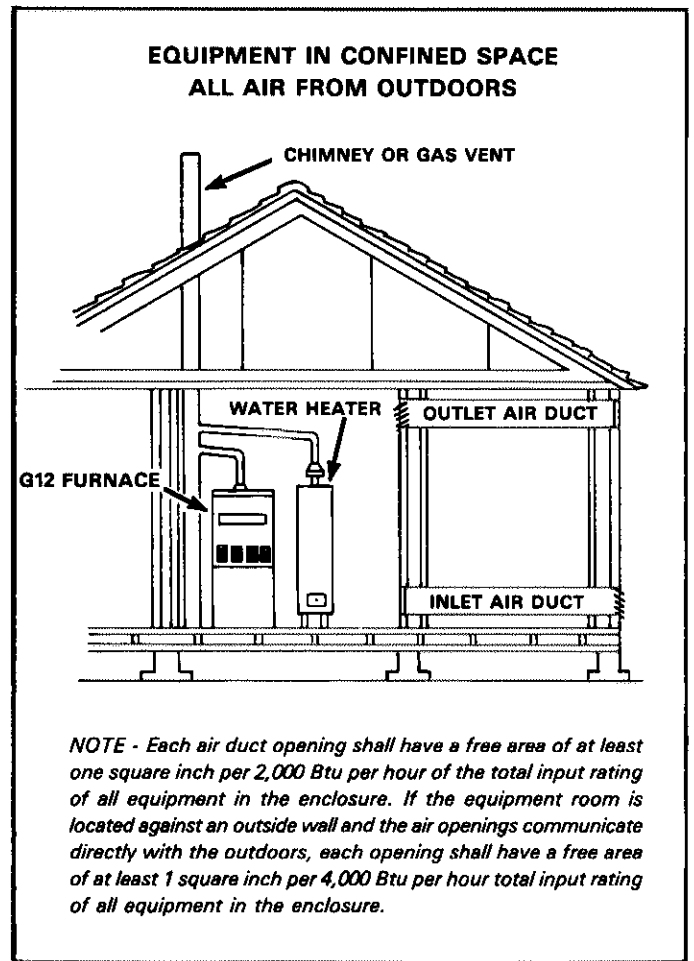

FIGURE 5

The following recommendations apply to all venting methods for G12 and G12E series units:

NOTE - The gas vent is defined as a passageway, vertical or nearly so, composed of listed factory-built components assembled in accordance with the terms of listing for conveying vent gases from gas appliances or their vent connectors to the outside atmosphere. The chimney is defined as a passageway, vertical or nearly so, for conveying vent gases to the outside atmosphere. The vent connector is defined as the pipe or duct which connects a fuel burning appliance to the vent or chimney.

- 1 - Vent connection materials must meet the requirements of the National Fuel Gas Code, ANSI-Z223.1-1984, or applicable provisions of local building codes.

2 - Vent connector pipe shall have an effective area equal to the effective area of the draft hood outlet. If no vent connector is used, the gas vent shall have at least an effective area equal to the effective area of the draft hood outlet. The vent connector or gas vent must be mechanically fastened with at least two sheet metal screws (See figure 6) except type B vent connectors or gas vents which should be assembled in accordance with the manufacturer's instructions.

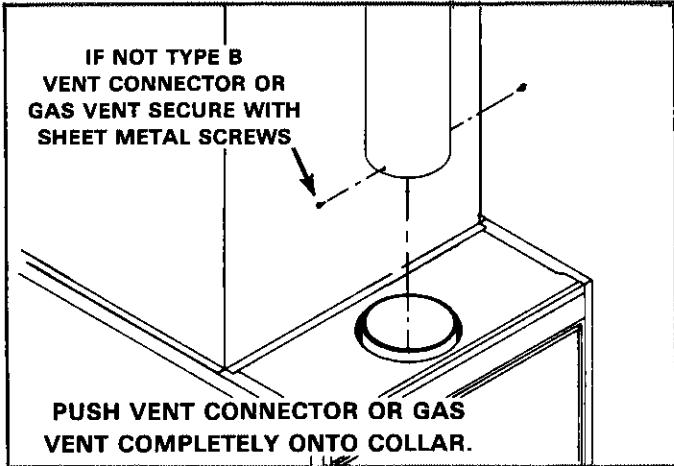

FIGURE 6

3 - Run vent connector to a chimney or gas vent using the least number of elbows and angles possible. The horizontal run of an uninsulated vent connector to the chimney or gas vent serving a single appliance must not be more than 75 percent of the height of the vertical portion of the chimney or gas vent above the vent connector. The horizontal run of an insulated vent connector serving a single appliance must not exceed the height of the vertical portion of chimney or gas vent above the vent connector.

The vent connector must have an upward slope toward the chimney or gas vent on all horizontal runs (minimum slope of 1/4 inch for each 12 inches of horizontal run).

Means shall be used that will prevent the vent connector from entering the chimney or gas vent to an extent that might restrict the space between the connector's end and the opposite wall of the chimney or gas vent.

Single-wall vent pipe is permissible for the entire length of the venting system, provided that this does not violate any local codes or, in the absence of local codes, the National Fuel Gas Code (ANSI-Z223.1-1984). For compliance, single-wall vent pipe must not originate in any unoccupied attic or concealed space and must not pass through any attic, inside wall or concealed space, or through any wall.

Clearances to combustible materials are 6 inches for single-wall vent pipe and 1 inch for type B-1 gas vent.

4 - All gas vents must be sized in height and capacity according to the National Fuel Gas Code (ANSI-Z223.1-1984). Refer to table 3 and figure 7 for sizing type B gas vents serving a single appliance. See table 4 and figure 7 for sizing single-wall metal vent pipe serving a single appliance. Regardless of the vent size shown, the gas vent must be equal to or larger than the vent connector. The gas vent must extend vertically at least 5 feet above the highest draft hood connection (See figure 7).

TABLE 3
SIZING TYPE B, DOUBLE-WALL VENTS WITH
TYPE B, DOUBLE-WALL VENT CONNECTORS
SERVING A SINGLE APPLIANCE

Height H	Lateral L	Vent Diameter - D				
		3"	4"	5"	6"	7"
Maximum Appliance Input Rating In Thousands of Btu Per Hour						
6'	0	46	86	141	205	285
	2'	36	67	105	157	217
	6'	32	61	100	149	205
8'	0	50	94	155	235	320
	2'	40	75	120	180	247
	8'	35	66	109	165	227
10'	0	53	100	166	255	345
	2'	42	81	129	195	275
	10'	36	70	115	175	245
15'	0	58	112	187	285	390
	2'	48	93	150	225	316
	15'	37	76	128	198	275
20'	0	61	119	202	307	430
	2'	51	100	166	249	346
	10'	44	89	150	228	321
	20'	35	78	134	206	295
30'	0	64	128	220	336	475
	2'	56	112	185	280	394
	20'	NR	90	154	237	343
40'	0	66	132	228	353	500
	2'	59	118	198	298	420
	20'	NR	96	167	261	377
	40'	NR	NR	NR	223	333

*NR indicates not recommended.

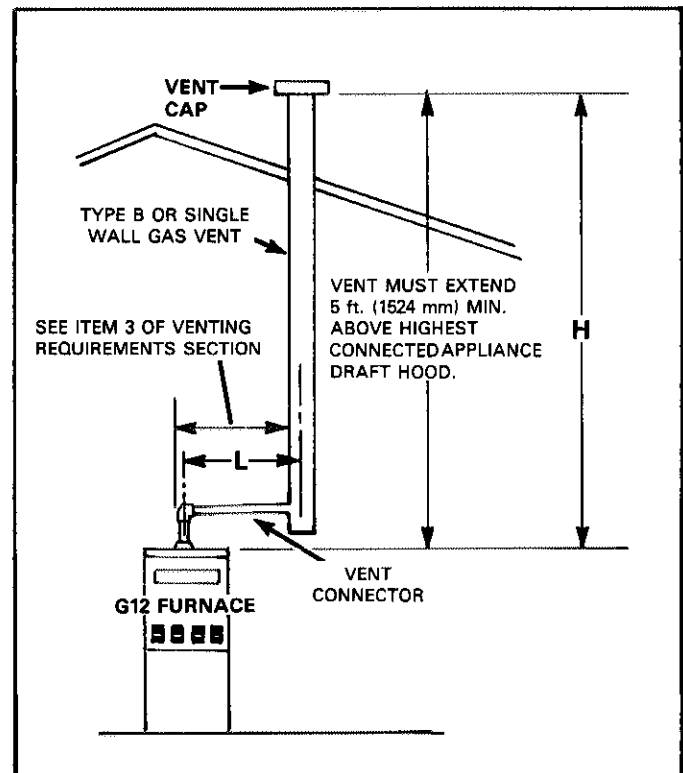

FIGURE 7

TABLE 4
SIZING SINGLE WALL METAL
VENT WITH SINGLE WALL VENT CONNECTOR
SERVING A SINGLE APPLIANCE

Height H	Lateral L	Vent Diameter - D				
		3"	4"	5"	6"	7"
Maximum Appliance Input Rating In Thousands of Btu Per Hour						
6'	0	39	70	116	170	232
	2'	31	55	94	141	194
	5'	28	51	88	128	177
8'	0	42	76	126	185	252
	2'	32	61	102	154	210
	5'	29	56	95	141	194
10'	0	45	84	138	202	279
	2'	35	67	111	168	233
	5'	32	61	104	153	215
	10'	27*	54	94	143	200
15'	0	49	91	151	223	312
	2'	39	72	122	186	260
	5'	35*	67	110	170	240
	10'	30*	58*	103	158	223
	15'	NR	50*	93*	144	207
20'	0	53*	101	163	252	342
	2'	42*	80	136	210	286
	5'	38*	74*	123	192	264
	10'	32*	65*	115*	178	246
	15'	NR	55*	104*	163	228
	20'	NR	NR	91*	149*	214*
30'	0	56*	108*	183	276	384
	2'	44*	84*	148*	230	320
	5'	NR	78*	137*	210	296
	10'	NR	68*	125*	196*	274
	15'	NR	NR	113*	177*	258*
	20'	NR	NR	99*	163*	240*
50'	0	NR	120*	210*	310*	443*
	2'	NR	96*	171*	260*	370*
	5'	NR	NR	159*	234*	342*
	10'	NR	NR	146*	221*	318*
	15'	NR	NR	NR	200*	292*
	20'	NR	NR	NR	185*	276*
30'	NR	NR	NR	NR	222*	

NR indicates not recommended.

Number followed by an "*" indicates possibility of continuous condensation, depending on locality. Consult local gas supplier and applicable local codes.

5 - Any masonry chimney used for venting a G12 or G12E series gas furnace must be lined, and must be sized and installed per all applicable local building codes or, in the absence of local codes, the National Fuel Gas Code (ANSI-Z223.1-1984). The effective area of the chimney serving a single appliance must be no less than the effective area of the draft hood outlet. The chimney must extend vertically at least 5 feet above the highest draft hood connection (See figure 8). Masonry chimneys serving fireplaces cannot be used for venting purposes unless the fireplace opening is permanently sealed. See figure 8. When inspection reveals that an existing chimney is not safe for the intended purpose, it shall be rebuilt to conform to nationally recognized standards, lined or relined with suitable materials or replaced with a gas vent or chimney suitable for venting the G12 or G12E unit. The chimney passageway must be checked periodically to ensure that it is clear and free of obstructions.

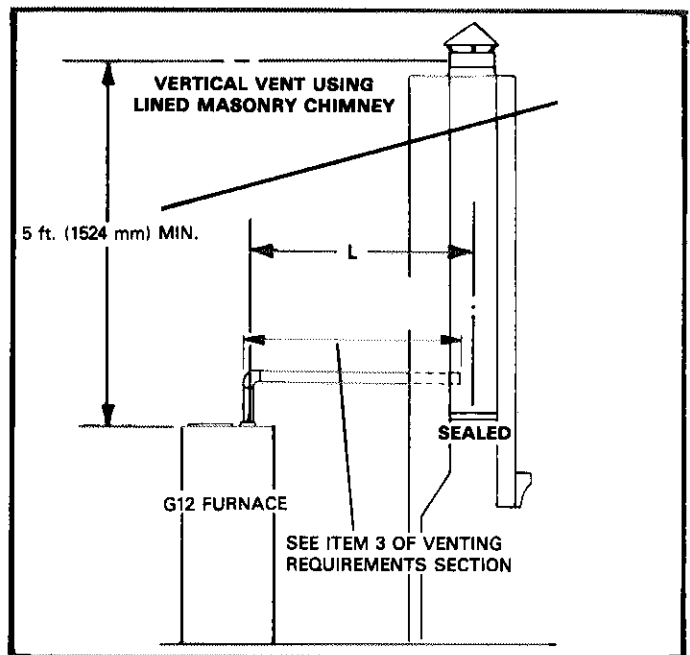

FIGURE 8

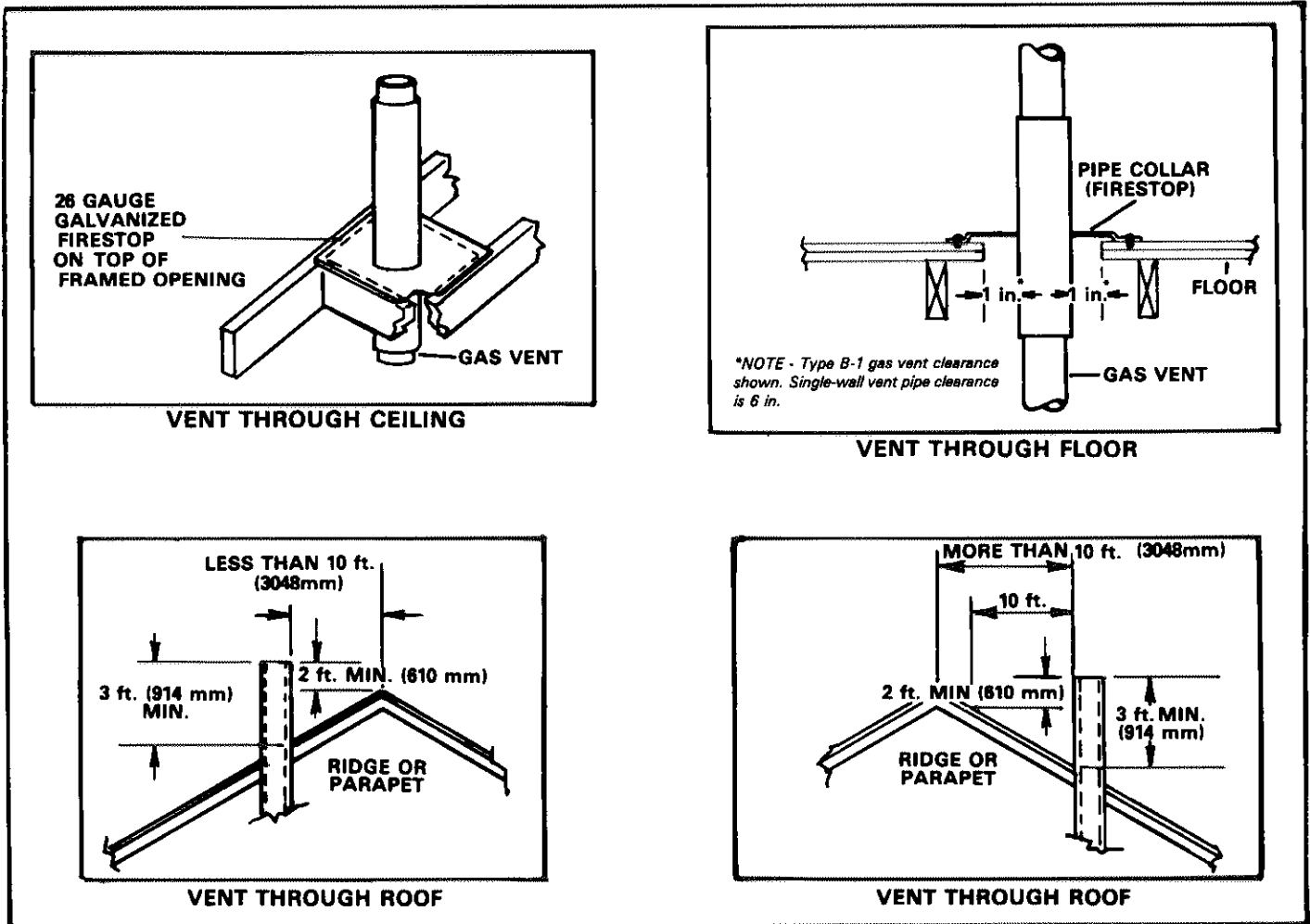

FIGURE 9

- 6 - All vent pipe passing through floors, ceilings and walls must be fire-stopped according to all applicable local building codes or, in the absence of local codes, the National Fuel Gas Code (ANSI-Z223.1-1984). See figure 9.
- 7 - The gas vent or chimney must extend 3 feet higher than the point of emergence through the roof and must be at least 2 feet higher than any object within a 10 foot radius (See figure 9.)
- 8 - Horizontal runs of vent piping must be supported every 5 feet using a sheet metal strap as shown in figure 10.
- 9 - No portion of any G12 or G12E gas vent should extend into, or pass through, any circulating air duct or plenum.
- 10 - All gas vent terminations must be located per all applicable local building codes or, in the absence of local codes, the National Fuel Gas Code (ANSI-Z223.1-1984).

- 11 - All gas vents or chimneys must be terminated with a U.L.-listed vent cap or rain shield assembly unless local codes require otherwise.
- 12 - The G12 or G12E gas furnace must not be connected to a chimney serving a separate appliance designed to burn solid fuel.

Common Venting of G12 or G12E Gas Furnace with Separate Gas Appliances

Single-wall vent pipe, type B double-wall vent pipe, or lined masonry chimney can be used for common venting of a G12 or G12E gas furnace and another appliance. The additional guidelines below must also be considered:

- 1 - In all cases, the gas vent or chimney must be sized and installed per the requirements of all applicable local building codes or, in the absence of local codes, the National Fuel Gas Code (ANSI-Z223.1-1984). Use table 5 to size type B, double-wall vent pipe serving two or more gas appliances. For single-wall vent sizing, see table 6. For masonry chimneys serving more than one appliance, see table 7. Figure 11 is used in sizing venting systems for common venting applications.

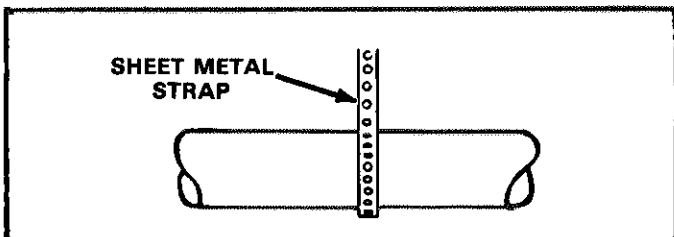

FIGURE 10

**TABLE 5
SIZING TYPE B, DOUBLE-WALL
VENTS SERVING TWO OR
MORE APPLIANCES**

Total Vent Height "H"	Common Vent Diameter					
	3"	4"	5"	6"	7"	8"
	Combined Appliance Input Rating in Thousands of Btu Per Hour					
6'	—	65	103	147	200	260
8'	—	73	114	163	223	290
10'	—	79	124	178	242	315
15'	—	91	144	206	280	365
20'	—	102	160	229	310	405
30'	—	118	185	266	360	470
40'	—	131	203	295	405	525

**TABLE 6
SIZING SINGLE WALL VENT
SERVING TWO OR MORE APPLIANCES**

Total Vent Height "H"	Common Vent Diameter				
	4"	5"	6"	7"	8"
	Combined Appliance Input Rating in Thousands of Btu Per Hour				
6'	48	78	111	155	205
8'	55	89	128	175	234
10'	59	95	136	190	250
15'	71	115	168	228	305
20'	80	129	186	260	340
30'	NR	147	215	300	400
50'	NR	NR	NR	360	490

*NR indicates not recommended.

**TABLE 7
SIZING LINED MASONRY CHIMNEY
SERVING TWO OR MORE APPLIANCES**

Total Vent Height "H"	Minimum Internal Area of Chimney — "A"					
	Square Inches					
	19	28	38	50	78	113
Combined Appliance Input Rating in Thousands of Btu Per Hour						
6'	45	71	102	142	245	NR
8'	52	81	118	162	277	405
10'	56	89	129	175	300	450
15'	66	105	150	210	360	540
20'	74	120	170	240	415	640
30'	NR	135	195	275	490	740
50'	NR	NR	NR	325	600	910

NR indicates not recommended.

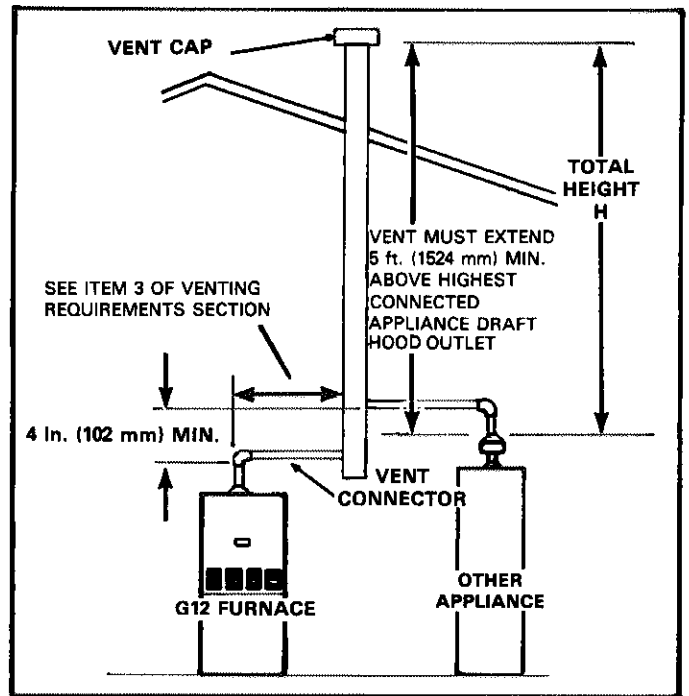

FIGURE 11

2 - When a common vent connector is used with a G12 or G12E gas furnace and another gas appliance, the vent connector and all fittings must be sized at least as large as the largest draft hood outlet plus 50 percent of the size of the additional draft hood outlets.

3 - Vent connectors serving naturally drafted equipment must not be connected into any portion of mechanically drafted systems operated under positive pressure.

IMPORTANT - The use of vent dampers with the G12 and G12E gas furnaces is not recommended because of the G12/G12E vent safety shut-off system.

FILTERS

"D" model furnaces are provided with slab-type filters and "Q" model furnaces are equipped with hammock-type filters. Refer to figure 12 for installation of slab filters.

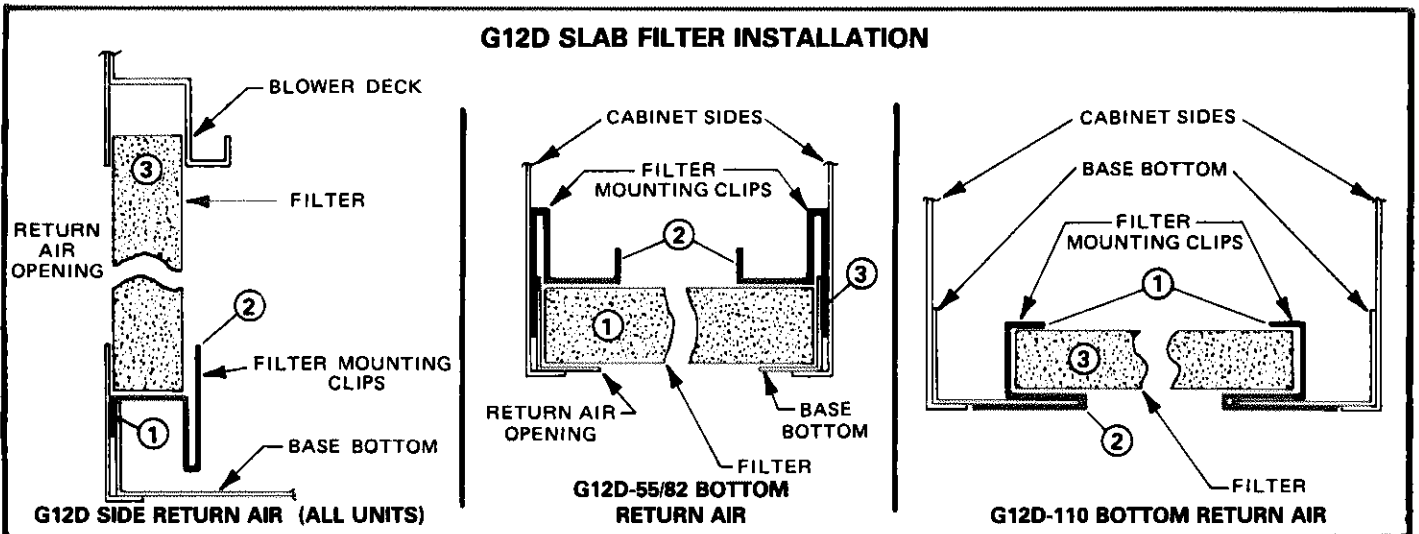

FIGURE 12

GAS PIPING

Gas Supply

- 1 - This unit is shipped standard for left-side installation of gas piping. Simply connect gas supply to piping assembly.
- 2 - A piping hole is also fabricated in the right side of the unit for alternate piping arrangements.
- 3 - When connecting gas supply, factors such as length of run, number of fittings and furnace rating must be considered to avoid excessive pressure drop. Table 8 lists recommended pipe sizes for typical applications.
- 4 - Gas piping must not run in or through air ducts, clothes chutes, chimneys or gas vents, dumb waiters or elevator shafts.
- 5 - Piping should be sloped 1/4 inch per 15 feet upward toward the meter from the furnace. The piping must be supported at proper intervals (every 8 to 10 feet) using suitable hangers or straps. A drip leg should be installed in vertical pipe run to the unit.
- 6 - In some localities, codes may require installation of a manual main shut-off valve and union (furnished by installer) external to unit. Union must be of the ground joint type.

IMPORTANT - Compounds used on threaded joints of gas piping must be resistant to the actions of liquified petroleum gases.

NOTE - Installer must provide a 1/8" N.P.T. plugged tap in the field piping upstream of the gas supply connection to unit. Tap must be accessible for test gauge connection. See figure 13.

NOTE - In case emergency shutoff is required, shut off the main manual gas valve and disconnect main power to unit. These devices should be properly labeled by installer.

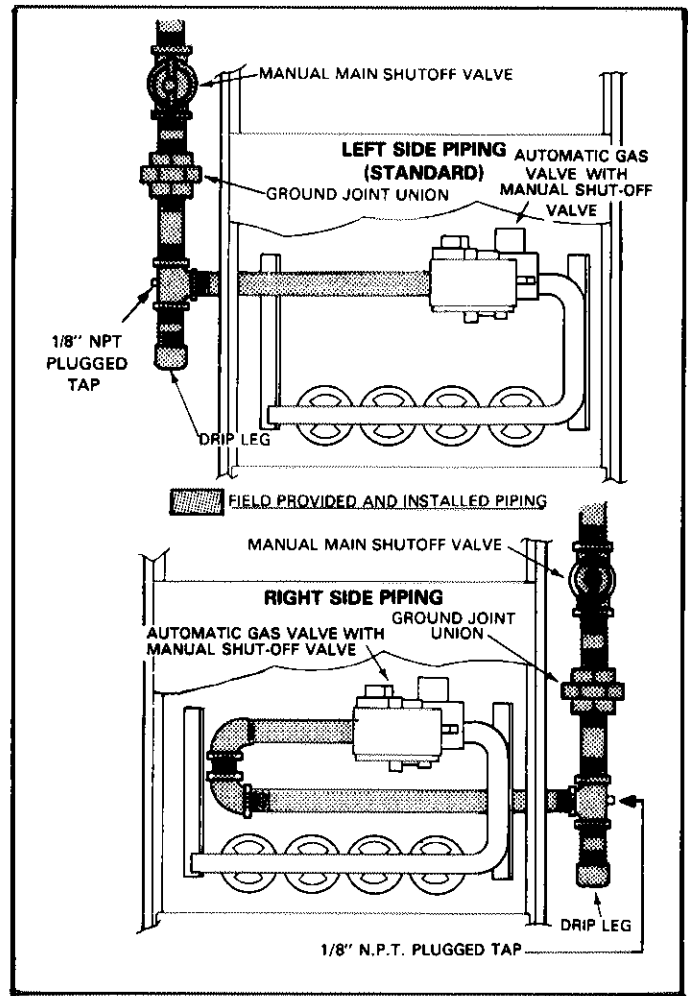

FIGURE 13

TABLE 8
Maximum Capacity of Gas Piping
At Pressures of 0.5 Psig (13.8" w.c.) or Less
and a Pressure Drop of 0.5 Inch Water Column*

Nominal Iron Pipe Size Inches	Internal Diameter, Inches	Length of Pipe, Feet									
		10	20	30	40	50	60	70	80	90	100
1/4	.364	43	29	24	20	18	16	15	14	13	12
3/8	.493	95	65	52	45	40	36	33	31	29	27
1/2	.622	175	120	97	82	73	66	61	57	53	50
3/4	.824	360	250	200	170	151	138	125	118	110	103
1	1.049	680	465	375	320	285	260	240	220	205	195
1-1/4	1.380	1,400	950	770	660	580	530	490	460	430	400
1-1/2	1.610	2,100	1,460	1,180	990	900	810	750	690	650	620
2	2.067	3,950	2,750	2,200	1,900	1,680	1,520	1,400	1,300	1,220	1,150
2-1/2	2.469	6,300	4,350	3,520	3,000	2,650	2,400	2,250	2,050	1,950	1,850
3	3.068	11,000	7,700	6,250	5,300	4,750	4,300	3,900	3,700	3,450	3,250
4	4.026	23,000	15,800	12,800	10,900	9,700	8,800	8,100	7,500	7,200	6,700

*Capacity given in cubic feet of gas per hour and based on 0.60 specific gravity gas.

High Altitude Derate

This appliance must be derated when installed at an elevation of 2,000 ft. (610m) or more above sea level. Tables 9 and 10 give the derated manifold pressure for high altitude operation with both natural and LP gas. Operating this appliance at the manifold pressure specified in the tables will ensure proper heat input at high altitudes. Consult your local gas utility for the local natural gas heating value.

NOTE - This is the only permissible field derate for this appliance.

TABLE 9
High Altitude Manifold Pressure Derate
for Natural Gas Units

ALTITUDE (FT.)	*HEATING VALUE (BTU/FT)				
	900	960	1000	1060	1100
0	4.32"wc	3.88"wc	3.60"wc	3.17"wc	2.89"wc
1000	4.32"wc	3.88"wc	3.50"wc	3.17"wc	2.89"wc
2000	3.65"wc	3.30"wc	2.95"wc	2.70"wc	2.45"wc
3000	3.35"wc	3.00"wc	2.70"wc	2.45"wc	2.25"wc
4000	3.05"wc	2.75"wc	2.45"wc	2.25"wc	2.04"wc
5000	2.77"wc	2.48"wc	2.25"wc	2.05"wc	1.85"wc
6000	2.50"wc	2.25"wc	2.00"wc	1.85"wc	1.65"wc

*Heating value based on atmospheric pressure of 30" mercury and temperature of 60°F (16°C).

TABLE 10
High Altitude Manifold Pressure Derate
for LP Gas Units

ALTITUDE (FT.)	0	1000	2000	3000	4000	5000	6000
MANIFOLD PRESSURE	10.5"wc	10.5"wc	8.9"wc	8.1"wc	7.4"wc	6.7"wc	6.1"wc

Leak Check

After gas piping is completed, carefully check all piping connections (factory and field) for gas leaks. Use a soap solution or other preferred means. Many soaps used for leak testing are corrosive to certain metals. Piping must be rinsed thoroughly with clean water after leak check has been completed.

CAUTION - Do not use matches, candles, flame or other sources of ignition to check for gas leaks.

IMPORTANT - The furnace and its individual shut-off valve must be disconnected from the gas supply piping system during any pressure testing of the system at test pressures in excess of 1/2 psig (3.45 kPa).

The Furnace must also be isolated from the gas supply piping system by closing its individual manual shut-off valve during any pressure testing of the gas supply piping system at test pressures equal to or less than 1/2 psig (3.45 kPa). See figure 14.

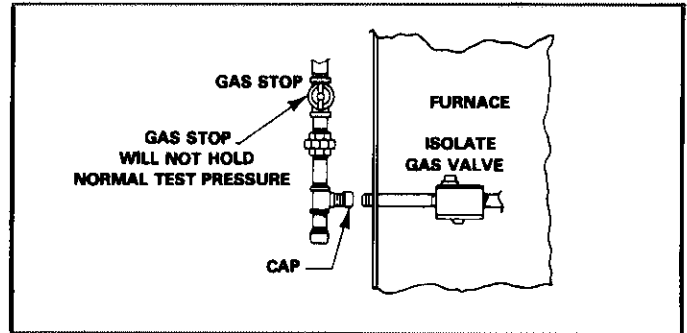
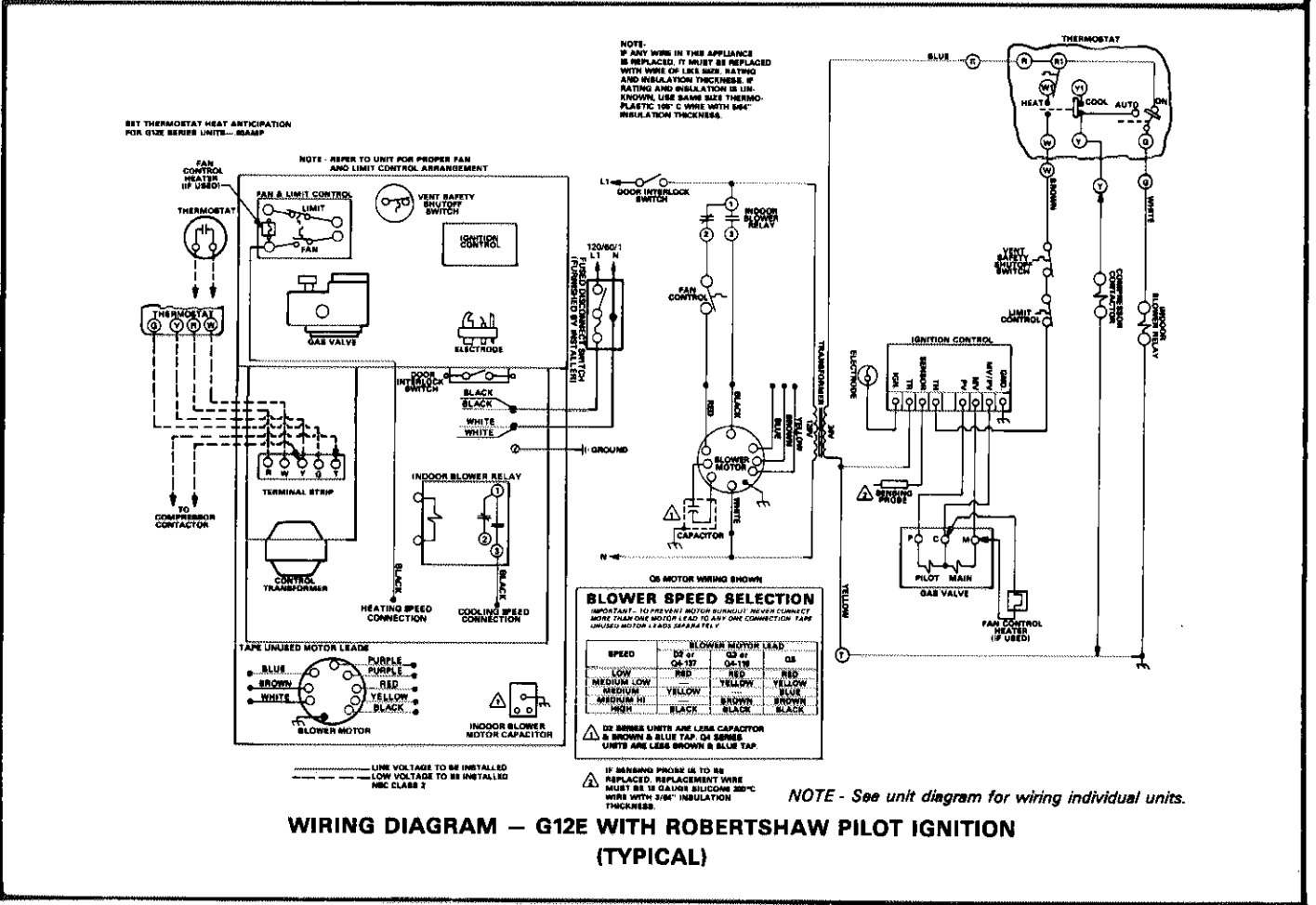
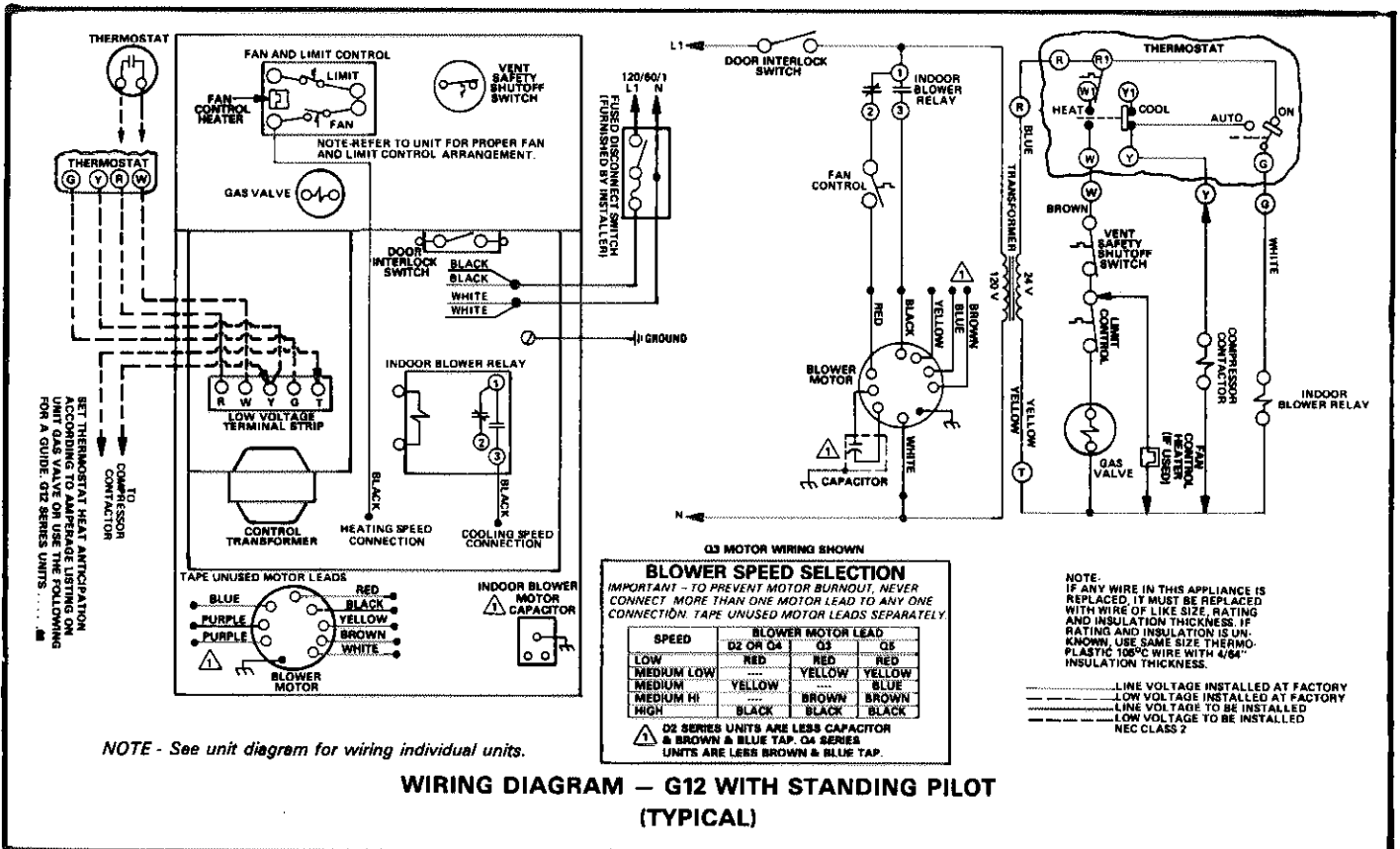

FIGURE 14

IV - ELECTRICAL

- 1 - Select fuse and wire sizes according to blower motor amps.
- 2 - Snaphole plugs are provided on both sides of cabinet to facilitate wiring
- 3 - Install room thermostat according to instructions provided with thermostat.
- 4 - Install a separate disconnect switch near unit so power can be turned off for servicing.
- 5 - Complete line voltage from disconnect switch to unit make-up box. Line wiring to unit must conform to the temperature limitation for type T wire, 63° F (35° C) rise.
- 6 - A ground screw is provided inside unit make-up box. Electrically ground unit in accordance with local codes or, in the absence of local codes with the National Electric Code.



SET THERMOSTAT HEAT ANTICIPATION FOR G12E SERIES UNITS... 30AMP

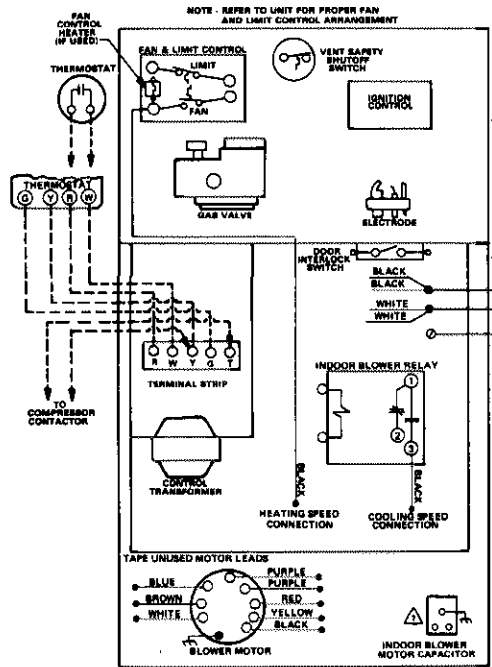

NOTE: IF ANY WIRE IN THIS APPLIANCE IS REPLACED, IT MUST BE REPLACED WITH WIRE OF LIKE SIZE, RATING AND INSULATION THICKNESS. IF RATING AND INSULATION IS UNKNOWN, USE SAME SIZE THERMOPLASTIC 105°C WIRE WITH 3/32" INSULATION THICKNESS.

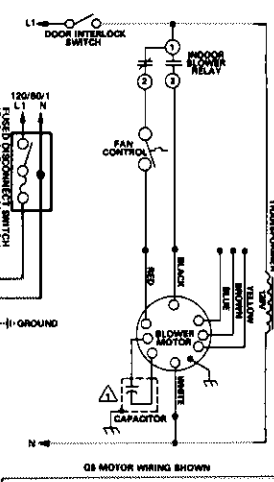

BLOWER SPEED SELECTION

IMPORTANT TO PREVENT MOTOR BURNOUT, NEVER CONNECT MORE THAN ONE MOTOR LEAD TO ANY ONE CONNECTION TAP UNLESS MOTOR LEAD SPARKS ARE Y

SPEED	D1 27	D2 34	D3 41	D4 116
LOW	OR 17	OR 16	OR 15	OR 14
MEDIUM LOW	RED	RED	RED	RED
MEDIUM	YELLOW	YELLOW	YELLOW	YELLOW
MEDIUM HI	BLACK	BROWN	BROWN	BROWN
HIGH	BROWN	BLACK	BLACK	BLACK

⚠️ D1 BLOWER UNITS AND LESS CAPACITOR LIMITS ARE LESS BROWN & BLUE TAP.

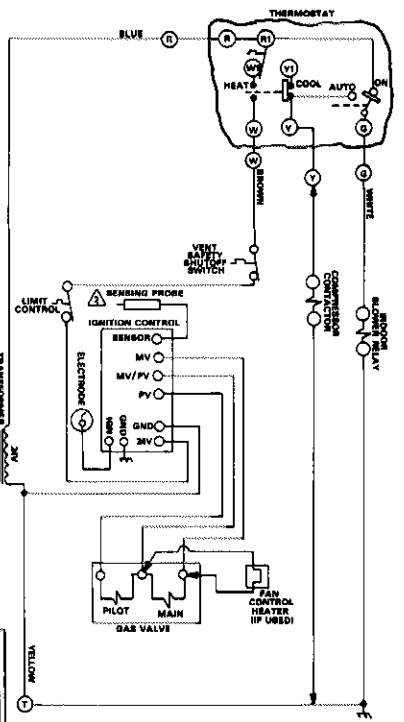

IF SENSING PROBE IS TO BE REPLACED, REPLACEMENT WIRE MUST BE 18 GAUGE SILICONE 200°C WIRE WITH 3/32" INSULATION THICKNESS.

--- LINE VOLTAGE TO BE INSTALLED
--- LOW VOLTAGE TO BE INSTALLED
NEC CLASS 2

NOTE - See unit diagram for wiring individual units.

WIRING DIAGRAM - G12E WITH WHITE-RODGERS GAS ENERGY SYSTEM (TYPICAL)

SET THERMOSTAT HEAT ANTICIPATION FOR G12E SERIES UNITS... 30 AMP

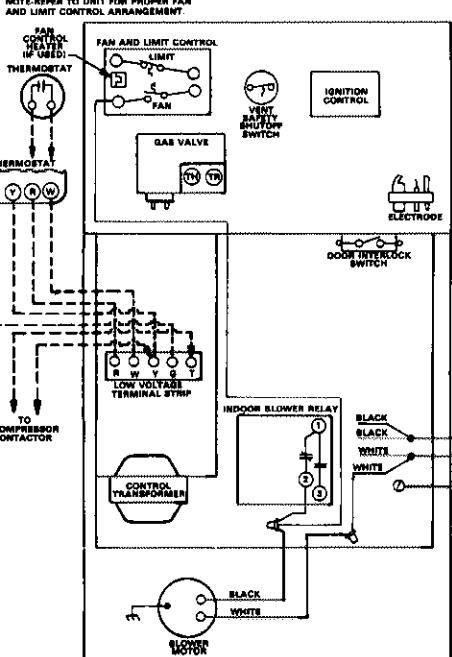

IF SENSING PROBE IS TO BE REPLACED, REPLACEMENT WIRE MUST BE 18 GAUGE SILICONE 200°C WIRE WITH 3/32" INSULATION THICKNESS.

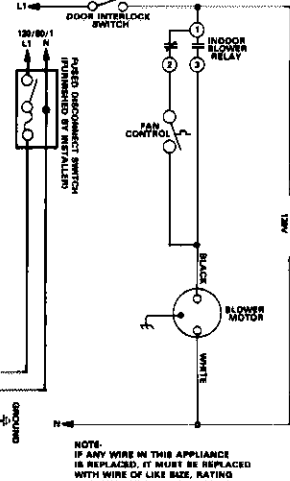

NOTE: IF ANY WIRE IN THIS APPLIANCE IS REPLACED, IT MUST BE REPLACED WITH WIRE OF LIKE SIZE, RATING AND INSULATION THICKNESS. IF RATING AND INSULATION IS UNKNOWN, USE SAME SIZE THERMOPLASTIC 105°C WIRE WITH 3/32" INSULATION THICKNESS.

--- LINE VOLTAGE TO BE INSTALLED
--- LOW VOLTAGE TO BE INSTALLED
NEC CLASS 2

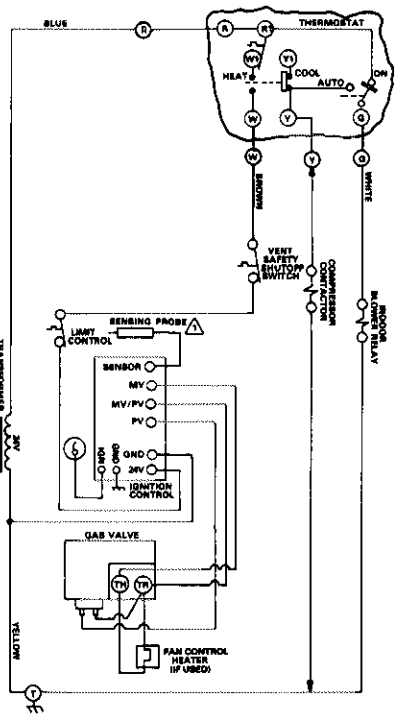

NOTE - See unit diagram for wiring individual units.



WIRING DIAGRAM - G12E-200 WITH WHITE-RODGERS GAS ENERGY SYSTEM (TYPICAL)

V - START-UP AND ADJUSTMENTS

START-UP

Furnaces with Manually Lighted Pilots

To place furnace into operation:

- 1 - With thermostat set below room temperature and power to the furnace turned off, turn the manual knob of the gas valve clockwise  to the stop. Depress and turn to "OFF" position. Wait 5 minutes.
- 2 - Turn manual knob of the gas valve counterclockwise  to the "ON" position. Turn manual knob of the gas valve clockwise  to the "PILOT" position.
- 3 - Depress knob and hold for 60 seconds after pilot has been lighted. Release knob and turn to "ON" position. If pilot goes out, repeat above instructions.
- 4 - Turn power on. Set thermostat to desired room temperature.



To shut furnace off:

- 1 - Set thermostat to lowest setting.
- 2 - Turn off power supply to the furnace.
- 3 - Turn manual knob of the gas valve clockwise  to the stop. Depress knob and turn to the "OFF" position.

Furnaces with Electronic Ignition ("E" models)

These units are equipped with an intermittent pilot ignition system. Do not attempt to manually light the pilot. Each time the thermostat calls for heat, an electric spark ignites the pilot. The pilot does not burn when there is no call for heat.

To place furnace into operation:

- 1 - With thermostat set below room temperature and power to furnace off, turn the manual knob of the gas valve clockwise  to the "OFF" position. Wait 5 minutes.
- 2 - Turn manual knob of gas valve counterclockwise  to the "ON" position. Turn power on and set thermostat above room temperature.
- 3 - If pilot does not light, repeat above instructions.
- 4 - Set thermostat to the desired room temperature.

To shut off furnace:

- 1 - Set thermostat to its lowest temperature and turn power supply to furnace off.
- 2 - Turn manual knob of the gas valve clockwise  to the "OFF" position.

FAN/LIMIT CONTROL

Limit control — Factory set — No adjustment necessary

Fan control — Factory set — ON - 115°F

OFF - 90°F

GAS FLOW

To check for proper gas flow to combustion chamber, determine Btu input from the appliance rating plate. Divide this input rating by the Btu per cubic foot of available gas. Result is the number

of cubic feet per hour required. Determine the flow of gas through the gas meter for 2 minutes and multiply by 30 to get the hourly flow of gas to the burner.

NOTE - Gas consumed by the standing pilot flame is 800 Btuh.

GAS PRESSURE

- 1 - Check gas line pressure with unit firing at maximum rate. A minimum of 7 inches (178 mm) w.c. for natural gas or 11 inches (279 mm) w.c. for LP gas should be maintained.
- 2 - After line pressure has been checked and adjusted, check regulator pressure. Correct manifold pressure for LP gas is 10.5 inches (267 mm) w.c. Correct regulator pressure for natural gas is 3.5 inches (89 mm) w.c.

TEMPERATURE RISE

Check temperature rise and, if necessary, adjust blower speed to maintain temperature rise within the range shown on unit rating plate.

ELECTRICAL

- 1 - Check all wiring for loose connections.
- 2 - Check for correct voltage at unit (with unit operating).
- 3 - Check amp-draw on blower motor.

Motor nameplate _____ Actual _____

FURNACE VENTING SYSTEM

- 1 - Check furnace venting system for any blockage and check all vent connections for tightness.
- 2 - Check unit for proper draft.

THERMOSTAT ANTICIPATION

Set the adjustable heat anticipator on the thermostat as follows:

G12 Series Units0.45 amp

G12E Series Units (GEI/White Rodgers)0.75 amp

G12E Series Units (Robertshaw).....0.60 amp

BLOWER SPEEDS

Multi-tap drive motors are wired for different heating and cooling speeds. Speed may be changed by simply interchanging motor connections at indoor blower relay and fan control. Refer to speed selection chart on unit wiring diagram.

CAUTION-To prevent motor burnout, never connect more than one motor lead to any one connection. Tape unused motor leads separately.

On 200 models, blower speed is regulated by means of an adjustable motor pulley. Open pulley to decrease speed and close pulley to increase speed. Adjust belt tension as loose as possible without slippage.

FAILURE TO OPERATE

If unit fails to operate, check the following:

- 1 - Is thermostat calling for heat?
- 2 - Is main disconnect switch closed?
- 3 - Is there a blown fuse?
- 4 - Is filter dirty or plugged? Dirty or plugged filters will cause unit to go off on limit control.
- 5 - Is gas turned on at meter?
- 6 - Is pilot lit? (Standing pilot units only)
- 7 - Is manual main shut-off valve open?
- 8 - Is internal manual shut-off valve open? (Electronic ignition models only)

After items 1 through eight have been checked and unit still will not start, manually reset vent safety shut-off switch located at right side of draft hood. If unit operation resumes and then cuts out again, inspect furnace vent system for proper sizing and installation. Also, check for vent blockage and for proper draft.

PILOT AND BURNER FLAME

- 1 - *Pilot Flame* — Adjust pilot burner to a soft blue flame (pilot adjustment screw is located on gas valve). The flame must surround the end of the pilot sensor for proper operation of the pilot safety circuit. See figure 15.

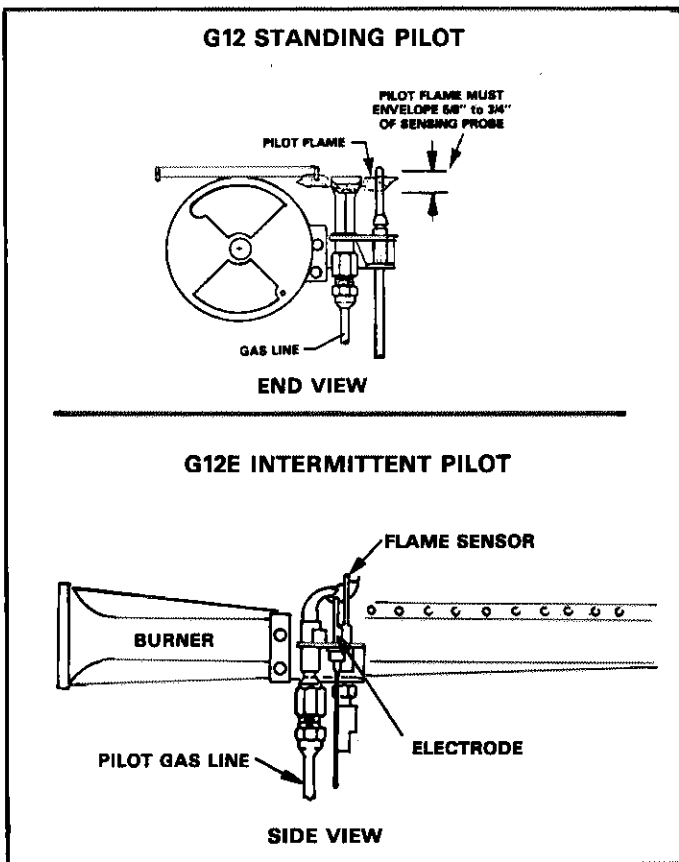
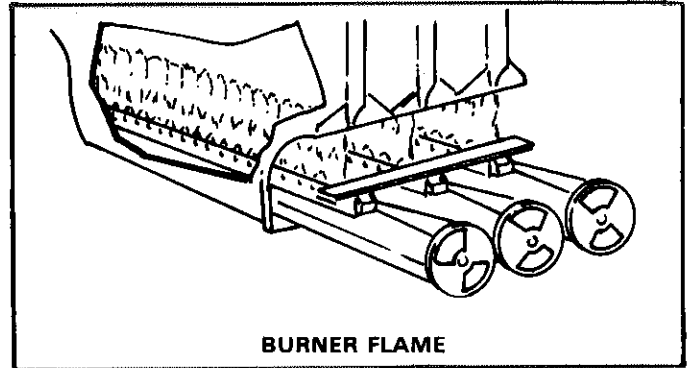

FIGURE 15

- 2 - *Burner Flame* — Start burner and allow to operate for a few minutes to establish normal burning conditions. Check burner flame by observation. Flame should be predominantly blue in color, strong in appearance and it should rise directly from the burner ports into the heat exchanger. Check to see that the flame is burning from all continuous ribbon ports and that the flame does not impinge on the sides of the heat exchanger. See figure 16.



BURNER FLAME

FIGURE 16

VI - SERVICE BLOWER

Check and clean blower wheel. Refer to lubrication information on blower access panel.

FILTERS

Filters must be replaced when dirty to assure proper furnace operation. Replace dirty filter with new filter of same size and type. Refer to filter information on blower access panel.

FURNACE VENTING SYSTEM

- 1 - Check furnace venting system for any blockage and check all vent connections for tightness.
- 2 - Check unit for proper draft.

ELECTRICAL CHECK

- 1 - Check all wiring for loose connections.
- 2 - Check for correct voltage at unit (unit operating).
- 3 - Check amp draw on blower motor.

Motor nameplate _____ Actual _____

CLEANING HEAT EXCHANGER AND BURNERS

NOTE - Use papers or protective covering in front of furnace while cleaning heat exchanger.

- 1 - Turn off both electrical and gas power supplies to the furnace. (Refer to figure 21 for parts identification for disassembly and reassembly procedures.)
- 2 - Remove upper furnace access panel, vestibule top panel, vent pipe, and draft diverter.
- 3 - Disconnect supply gas piping, pilot and thermocouple line. Remove piping manifold.
- 4 - Remove pouch cover, then pull burners from heat exchanger.
- 5 - Remove baffles inside top opening of heat exchanger by twisting tabs to align with slots in baffles.
- 6 - Insert a 2 ft. long steel rod that has a 20 in. length of chain attached to one end into top opening of heat exchanger. See figure 17.

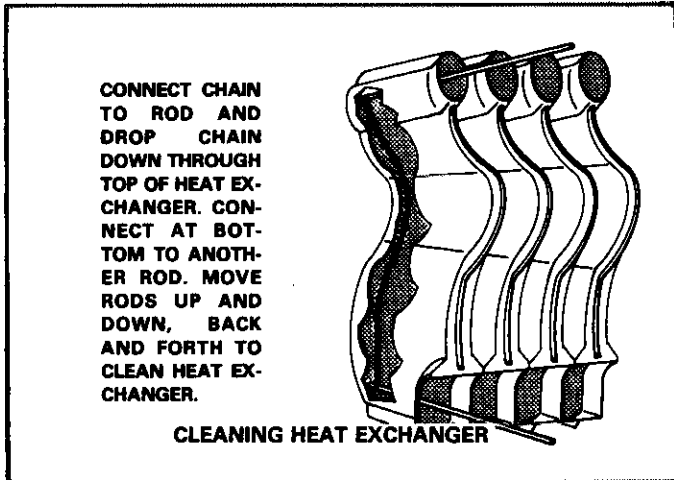
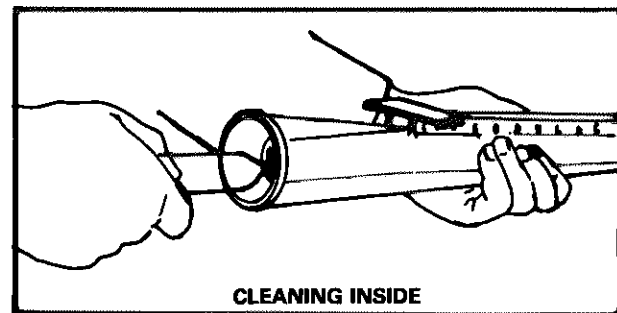
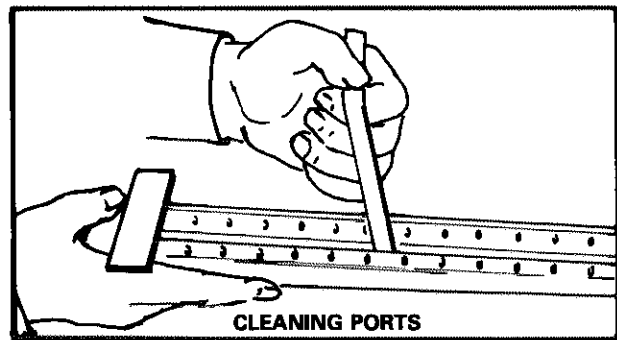
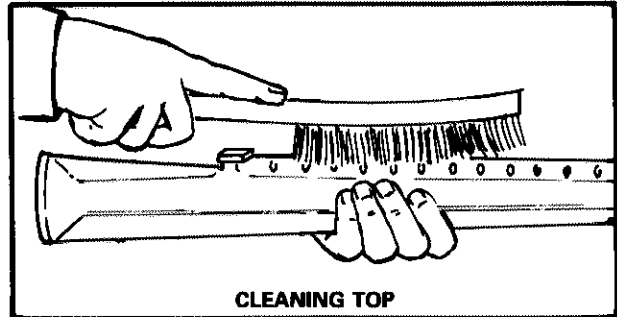

FIGURE 17

- 7 - "Shake" the rod so that the chain drops through the clamshell into the burner cavity in the bottom of the heat exchanger.
- 8 - Attach the bottom of the chain to another 2 ft. long rod.
- 9 - Push and pull the rods back and forth and up and down with a vigorous motion. The chain will dislodge the soot and scale deposits inside the heat exchanger. Repeat for each clamshell.
- 10 - With shop vacuum or rags, clean out the soot and scale deposits from the bottom of the heat exchanger.

To clean the burners:

- 11 - Clean top of burner with a wire brush. See figure 18.
- 12 - Clean burner ports by inserting cleaning a tool (made from a piece of sheet metal cut to fit the burner ports) and work in and out of each port. See figure 19.
- 13 - Clean inside each burner with a bottle cleaning brush. See figure 20.



- 14 - Replace burners making sure to fully engage in rear receiving slot in heat exchanger. Resecure gas manifold, piping, thermocouple and pouch cover.
- 15 - Reinstall baffles inside top opening of heat exchanger (twist tabs to secure), then replace draft diverter, vestibule top panel and flue pipe.
- 16 - Turn on gas and electrical supply, light pilot (standing pilot units only) and replace access panels.
- 17 - Check for gas leaks.
- 18 - Check pilot and burner flame.

VII - REPAIR PARTS LIST

The following repair parts are available through independent Lennox dealers. When ordering parts, include the complete furnace model number listed on the A.G.A. nameplate — Example: G12Q3-137-2.

CABINET PARTS

- Louvered panel
- Blower panel
- Top front piece
- Vestibule top strip
- Filter rack for hammock-type filters
- Control box cover
- Pouch cover

HEATING PARTS

- Heat exchanger
- Flue baffles
- Draft hood
- Main burners
- Main burner orifices
- Main burner air shutters
- Pilot burner
- Pilot orifice
- Pilot mounting bracket
- Gas manifold
- Gas valve
- Thermocouple (manually lighted pilot models)
- Ignition control (electronic ignition models)
- Ignition cable (electronic ignition models)
- Flame sensor lead (electric ignition models)
- Fan and limit control
- Vent safety shut-off switch

CONTROL PANEL PARTS

- Transformer
- Indoor blower relay

BLOWER PARTS

- Blower wheel
- Motor
- Motor mounting frame
- Motor capacity (Q series)
- Blower housing cut-off plate

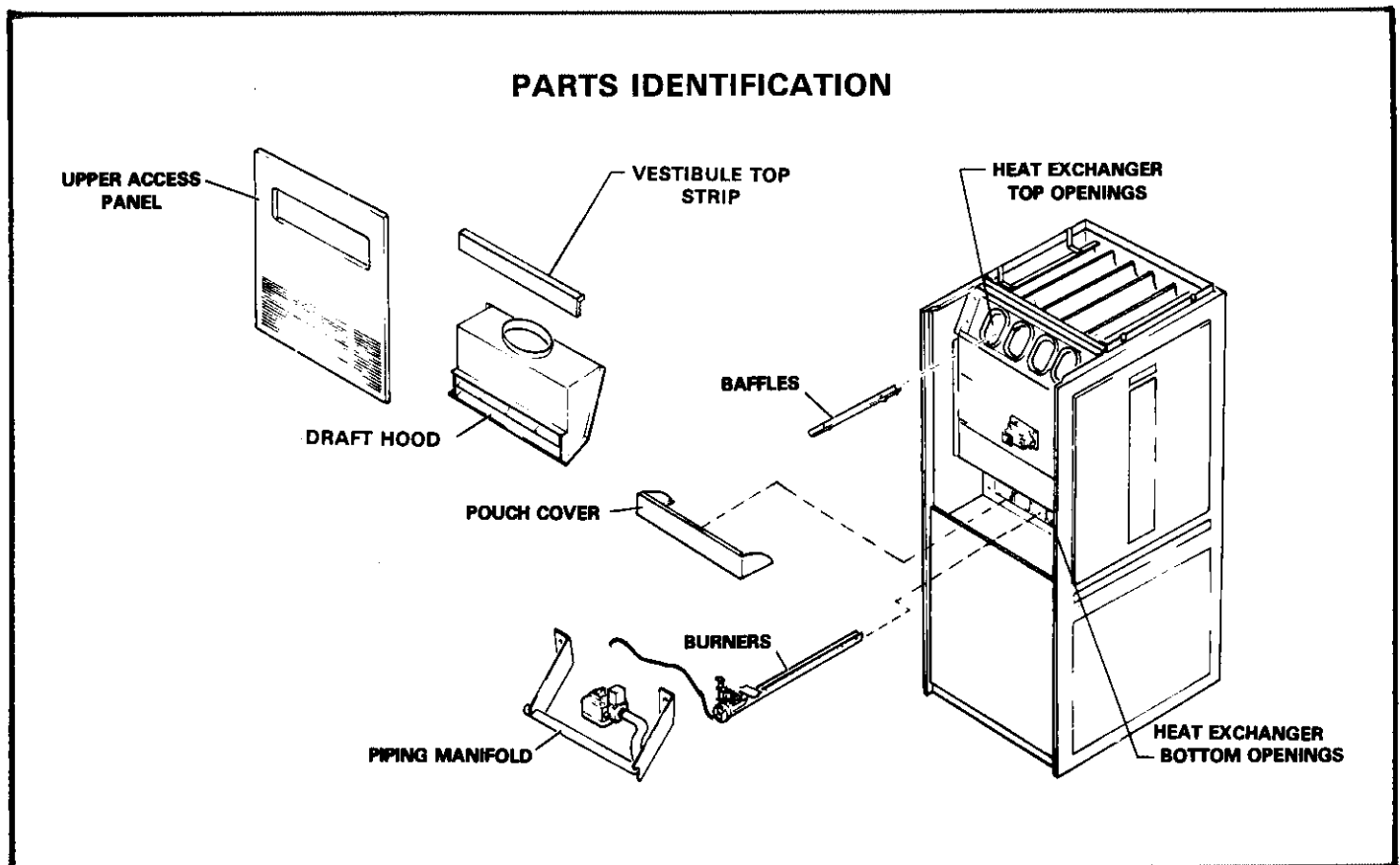

FIGURE 21