

# LENNOX G-14

MODEL NUMBER: Upflow - "PULSE"

BTU SIZES: 40,000 - 130,000 BTU's

## ACCESSIBILITY CLEARANCE

Service access 36" to the front, 6" on the exhaust side of the furnace.

## CLEARANCE FROM COMBUSTIBLE MATERIAL

Clearance to combustible materials:

Sides .....	1"
Rear .....	1"
Top .....	1"
Front .....	6"
Exhaust .....	0

## COLD AIR RETURN AIR DUCTS

A flexible canvass boot or equivalent should be used and located as close to the furnace as possible.

Must be insulated with 1" insulation past the first elbow.

Electrical conduit to be isolated from duct work.

Must be sealed to the furnace.

## GARAGE

Approved. Must meet requirements in the UMC and the Good Practice Book.

## GENERAL

Furnace must be electrically grounded. Gas piping must not come in contact with furnace cabinet.

Unit should not sit directly on floor. Isolation pads or leveling bolts are to be used.

Flexible connector not to run through furnace cabinet.

### HIGH ALTITUDE INSTALLATIONS

Deration	Deration is not necessary due to the self-compensating effect of the pulse combustion process unless installed at elevations above 6,000 ft, then deration is 4% for each 1,000 ft above sea level.
Orifice	One orifice size specifically designed for each unit. Standard atmospheric orifices or orifice blanks cannot be used.
Regulator Pressure	Specified on name plate.
Air Intake Vacuum Switch	Normally closed - automatic reset.

### MOBILE HOME

Approved.

### VENTING MATERIAL AND REQUIREMENTS

Vent Pipe	PVC Schedule 40 Type 1130 or 1220
Vent Fittings	PVC or PVC12

Vent pipes must be installed with isolation hangers (plumber tape and Armaflex insulation).

### VENT CLEARANCE FROM COMBUSTIBLE MATERIAL

0"

For service access to exhaust 6" from side of unit.

### VENTING PROCEDURE

See attached sheet for terminations, vertical venting is preferred.

Maximum length is 35 feet with 4 elbows. Locate air intake piping upwind of exhaust piping, both must be in the same pressure zone. Do not pipe one vertical and one horizontal, or on opposite sides. If winter design temperature is below 32 degrees F, exhaust must be insulated with 1/2" Armaflex in an unheated space.

Do not point intake and termination elbows into window wells, stairwells, alcoves, courtyard, or other recessed areas. Combustion air intake inlet should not be located within 6 feet of a dryer vent, condensing unit or combustion air inlet or outlet of another appliance. Piping should not exit less than 3 feet from opening into another building.

MISCELLANEOUS INFORMATION/NOTES

Lifetime warranty on heat exchanger.

Heat anticipator setting

Robertshaw valve = .8

White Rogers valve = .9

Furnace will produce 5 gallons of condensate on a mid-winter day.

Combustion process stops on:

Blocked air intake

Blocked exhaust

Hole in combustion chamber

Material used for gas and air flappers has a normal 8 year life expectancy.

Blower motor should be oiled every 2-5 years.



# ELECTRICAL

- 1 - Select fuse and wire size according to blower motor amps.
- 2 - Snapola plugs are provided on both sides of cabinet to facilitate wiring.
- 3 - Install room thermostat according to instruction provided with thermostat.
- 4 - Install a separate fused disconnect switch near the unit so the power can be turned off for servicing.
- 5 - Complete wiring connections to equipment using provided wiring diagrams.
- 6 - Electrically ground unit in accordance with local codes, or in the absence of local codes in accordance with the National Electric Code.

LENNOX G14

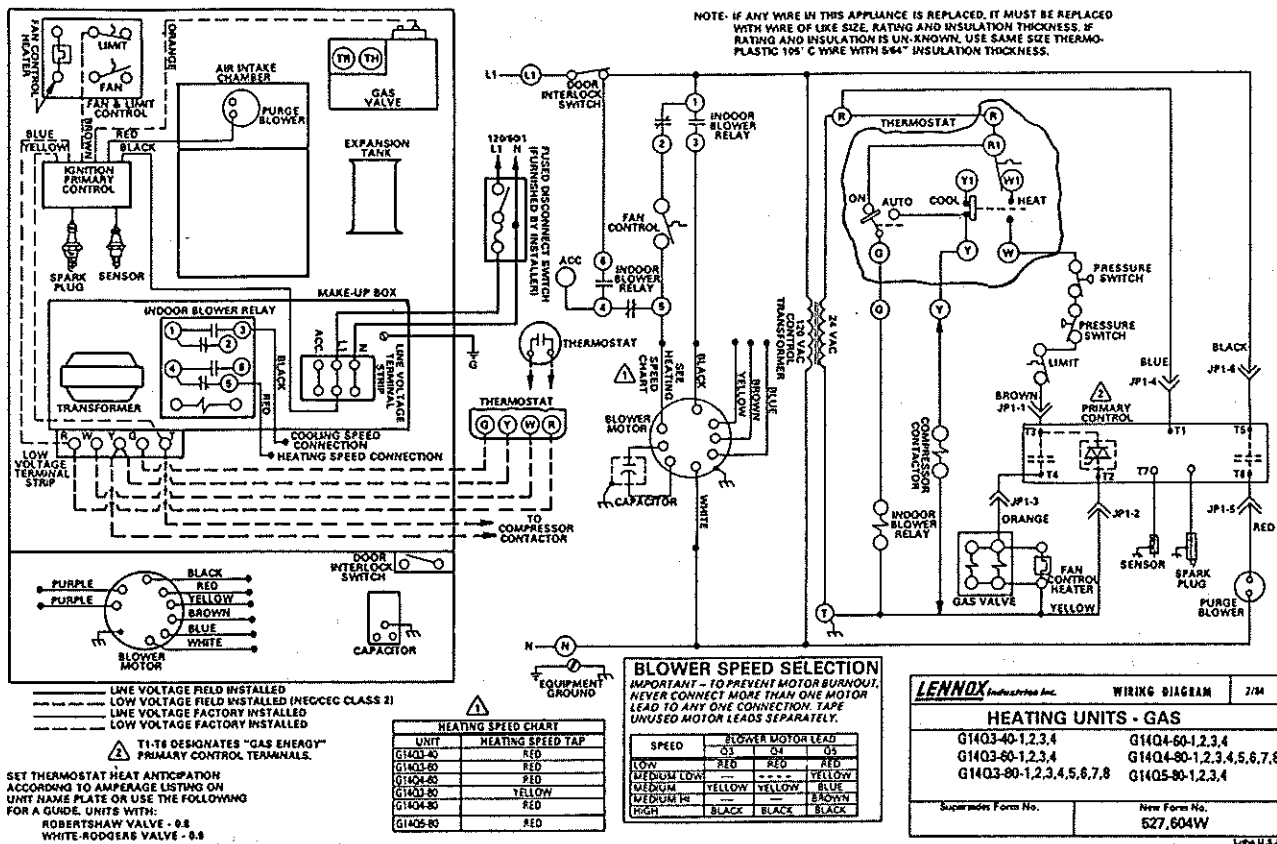

## START-UP/ADJUSTMENTS

### START-UP

This unit is equipped with a direct spark ignition system with flame rectification. Once combustion has started, the purge blower and spark ignitor are turned off. To place furnace in operation:

- 1 - With thermostat set below room temperature and power to furnace off, turn manual knob of gas valve clockwise to the OFF position. Wait 5 minutes.
- 2 - Turn manual knob of gas valve counterclockwise to ON position. Turn power on and set thermostat above room temperature. Unit will go into prepurge for 30 seconds and then ignite.
- 3 - If the unit does not light on the first attempt, it will attempt four more ignitions before locking out.
- 4 - If lockout occurs, turn thermostat off and then back on.

### To shut off furnace:

- 1 - Set thermostat to lowest temperature and turn power supply to furnace off.
- 2 - Turn manual knob of gas valve off.

### FAILURE TO OPERATE

If unit fails to operate, check the following:

- 1 - Is thermostat calling for heat?
- 2 - Is main disconnect switch closed?
- 3 - Is there a blown fuse?
- 4 - Is filter dirty or plugged? Dirty or plugged filters will cause unit to go off on limit control.
- 5 - Is gas turned on at meter?
- 6 - Is manual main shut off valve open?
- 7 - Is internal manual shut off open?
- 8 - Are intake and exhaust pipes clogged?
- 9 - Is primary control locked out? (Turn thermostat off and then back on.) If unit fails to start, refer to troubleshooting chart on pages 11 and 12.

### GAS FLOW

To check proper gas flow to combustion chamber, determine BTU input from the appliance rating plate. Divide this input rating by the BTU per cubic foot of available gas. Result is the number of cubic feet per hour required. Determine the flow of gas through gas meter for 2 minutes and multiply by 30 to get the hourly flow of gas to burner.

LENNOX G-14  
Schematic Explanation

Line voltage power enters at "L1" passing through the fan door interlock switch (Fan door must be in place). From the fan door switch power goes 2 ways. One to the open set of contacts at terminal "6" on the indoor blower relay. The other one goes to terminal "1" also on the indoor blower relay through the normally closed set of contacts at terminal "2" of the indoor blower relay and on to the fan control. Line voltage power also goes over to provide 110 volts to the line voltage side of the transformer and then completes back to "N". Line voltage power also continues over through connection "6" of the JP1 connector to the open set of contacts at terminal "T5" of the module.

Low voltage power leaves the secondary side of the transformer and goes to the "R" terminal of the low voltage terminal strip, completion for the low voltage system is at terminal "T" of the low voltage terminal strip. From the "R" terminal low voltage power is sent through connection "4" of the JP1 connector to terminal "T1" of the module which provides power for the operation of the purge blower during the post purge cycle. From the "R" terminal power also goes to the "R" terminal of the thermostat.

As the thermostat closes power goes from "R" to "W" and leaves the thermostat and goes back to the "W" terminal on the low voltage terminal strip. It leaves the "W" terminal and goes through the normally closed contacts of the pressure switch and limit switch through connection 1 of the JP1 connector to terminal "T3" on the module which provides power to the timer control of the module this completes from terminal "T2" through connection "2" on the JP1 connector to the "T" terminal on the low voltage terminal strip.

With the thermostat closed and power between terminals "T3" and "T2" the open contacts between "T5" and "T6" close sending line voltage through connection "5" of the JP1 connector causing the purge blower which completes back to "N" to begin the prepurge cycle. At the end of the prepurge cycle the purge blower continues to operate. The open set of contacts between "T3" and "T4" close energizing the gas valve and fan control heater from "T4" of the module through connection "3" of the JP1 connector, the spark plug is also energized. Ignition of the flame should occur and the pulse combustion should begin.

The flame sensor at terminal "T7" verifies ignition by flame rectification which shuts off the spark and the purge blower. The pulse combustion process continues.

After approximately 30 seconds the fan control heater will close the normally open contacts of the fan control causing power to be sent through terminal "5" of the indoor blower relay to the blower motor and capacitor which completes back to "N".

After the thermostat is satisfied and opens removing power from the module. The low voltage power at "T1" activates the purge blower for the post purge cycle. The indoor blower will continue to run until the air temperature lowers to 90 degrees.

- 1 - Select fuse and wire size according to blower motor amps.
- 2 - Snaphole plugs are provided on both sides of cabinet to facilitate wiring.
- 3 - Install room thermostat according to instruction provided with thermostat.
- 4 - Install a separate fused disconnect switch near the unit so the power can be turned off for servicing.
- 5 - Complete wiring connections to equipment using provided wiring diagrams.
- 6 - Electrically ground unit in accordance with local codes, or in the absence of local codes in accordance with the National Electric Code.

LENNOX G-14

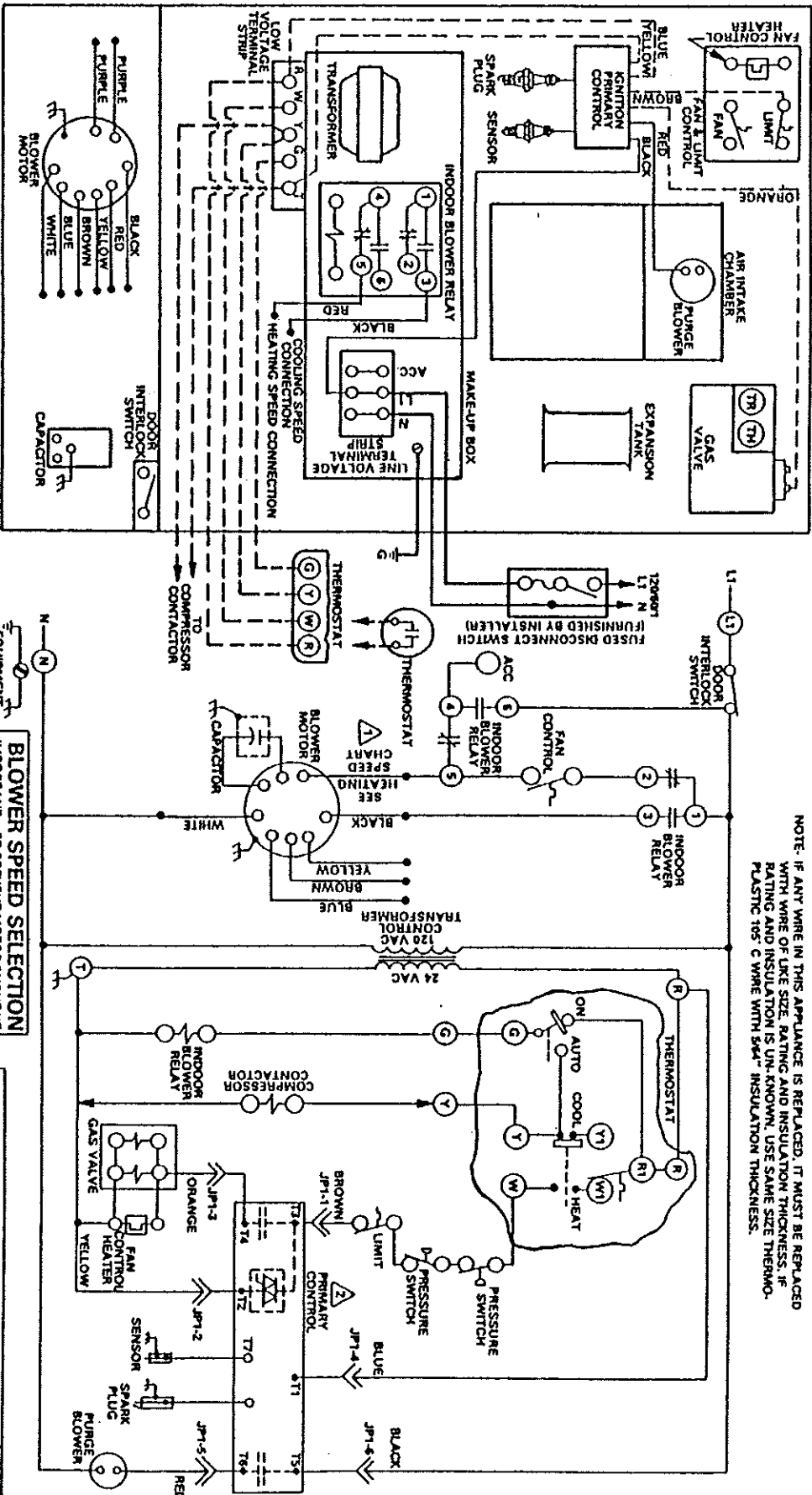

NOTE: IF ANY WIRE IN THIS APPLIANCE IS REPLACED, IT MUST BE REPLACED WITH WIRE OF LIKE SIZE, RATING AND INSULATION THICKNESS. IF RATING AND INSULATION IS UN-KNOWN, USE SAME SIZE THERMO-PLASTIC TYS C WIRE WITH 844" INSULATION THICKNESS.

LINE VOLTAGE FIELD INSTALLED (NIBCEC CLASS 2)  
 LOW VOLTAGE FIELD INSTALLED  
 LOW VOLTAGE FACTORY INSTALLED

1-T8 DESIGNATES "GAS ENERGY" PRIMARY CONTROL TERMINALS.

SET THERMOSTAT HEAT ANTICIPATION ACCORDING TO AMPERAGE LISTING ON UNIT NAME PLATE OR USE THE FOLLOWING FOR A GUIDE. UNITS WITH:  
 ROBERTSHAW VALVE - 0.9  
 WHITE-RODGERS VALVE - 0.9

UNIT	HEATING SPEED TAP
G1403-40	RED
G1403-80	RED
G1404-80	RED
G1404-80	YELLOW
G1404-80	RED
G1405-80	RED

**BLOWER SPEED SELECTION**  
 IMPORTANT - TO PREVENT MOTOR BURNOUT, NEVER CONNECT MORE THAN ONE MOTOR LEAD TO ANY ONE CONNECTION. TAPE UNUSED MOTOR LEADS SEPARATELY.

SPEED	BLOWER MOTOR LEAD
LOW	O1 RED
MEDIUM LOW	O2 RED
MEDIUM	O3 YELLOW
MEDIUM HI	O4 YELLOW
HIGH	O5 BLUE

**LENNOX** Industries Inc. WIRING DIAGRAM 71M

HEATING UNITS - GAS	
G1403-40-1,2,3,4	G1404-80-1,2,3,4
G1403-80-1,2,3,4	G1404-80-1,2,3,4,5,6,7,8
G1403-80-1,2,3,4,5,6,7,8	G1405-80-1,2,3,4

Submit Form No. 527 New Form No. V  
 Made in U.S.A.





LENNOX G-14  
Schematic Explanation

Line voltage power enters at "L1" passing through the fan door interlock switch (Fan door must be in place). From the fan door switch power goes 2 ways. One to the open set of contacts at terminal "6" on the indoor blower relay. The other one goes to terminal "1" also on the indoor blower relay through the normally closed set of contacts at terminal "2" of the indoor blower relay and on to the fan control. Line voltage power also goes over to provide 110 volts to the line voltage side of the transformer and then completes back to "N". Line voltage power also continues over through connection "6" of the JP1 connector to the open set of contacts at terminal "T5" of the module.

Low voltage power leaves the secondary side of the transformer and goes to the "R" terminal of the low voltage terminal strip, completion for the low voltage system is at terminal "T" of the low voltage terminal strip. From the "R" terminal low voltage power is sent through connection "4" of the JP1 connector to terminal "T1" of the module which provides power for the operation of the purge blower during the post purge cycle. From the "R" terminal power also goes to the "R" terminal of the thermostat.

As the thermostat closes power goes from "R" to "W" and leaves the thermostat and goes back to the "W" terminal on the low voltage terminal strip. It leaves the "W" terminal and goes through the normally closed contacts of the pressure switch and limit switch through connection 1 of the JP1 connector to terminal "T3" on the module which provides power to the timer control of the module this completes from terminal "T2" through connection "2" on the JP1 connector to the "T" terminal on the low voltage terminal strip.

With the thermostat closed and power between terminals "T3" and "T2" the open contacts between "T5" and "T6" close sending line voltage through connection "5" of the JP1 connector causing the purge blower which completes back to "N" to begin the prepurge cycle. At the end of the prepurge cycle the purge blower continues to operate. The open set of contacts between "T3" and "T4" close energizing the gas valve and fan control heater from "T4" of the module through connection "3" of the JP1 connector, the spark plug is also energized. Ignition of the flame should occur and the pulse combustion should begin.

The flame sensor at terminal "T7" verifies ignition by flame rectification which shuts off the spark and the purge blower. The pulse combustion process continues. After approximately 30 seconds the fan control heater will close the normally open contacts of the fan control causing power to be sent through terminal "5" of the indoor blower relay to the blower motor and capacitor which completes back to "N".

After the thermostat is satisfied and opens removing power from the module. The low voltage power at "T1" activates the purge blower for the post purge cycle. The indoor blower will continue to run until the air temperature lowers to 90 degrees.



# TROUBLESHOOTING

## G14 TROUBLE SHOOTING FLOW CHART

NOTE: REFER TO ILLUSTRATIONS ON OPPOSITE PAGE FOR NUMBERED CHECKS.

### ELECTRICAL CHECKS

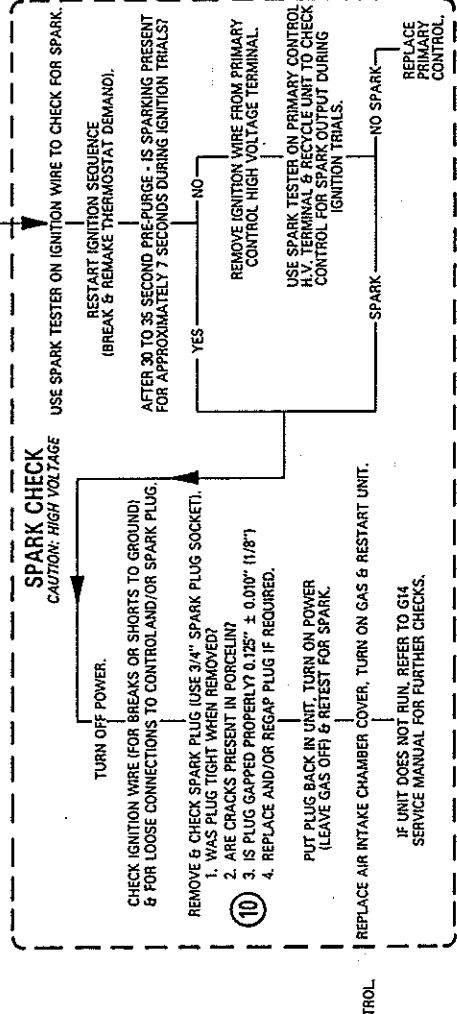
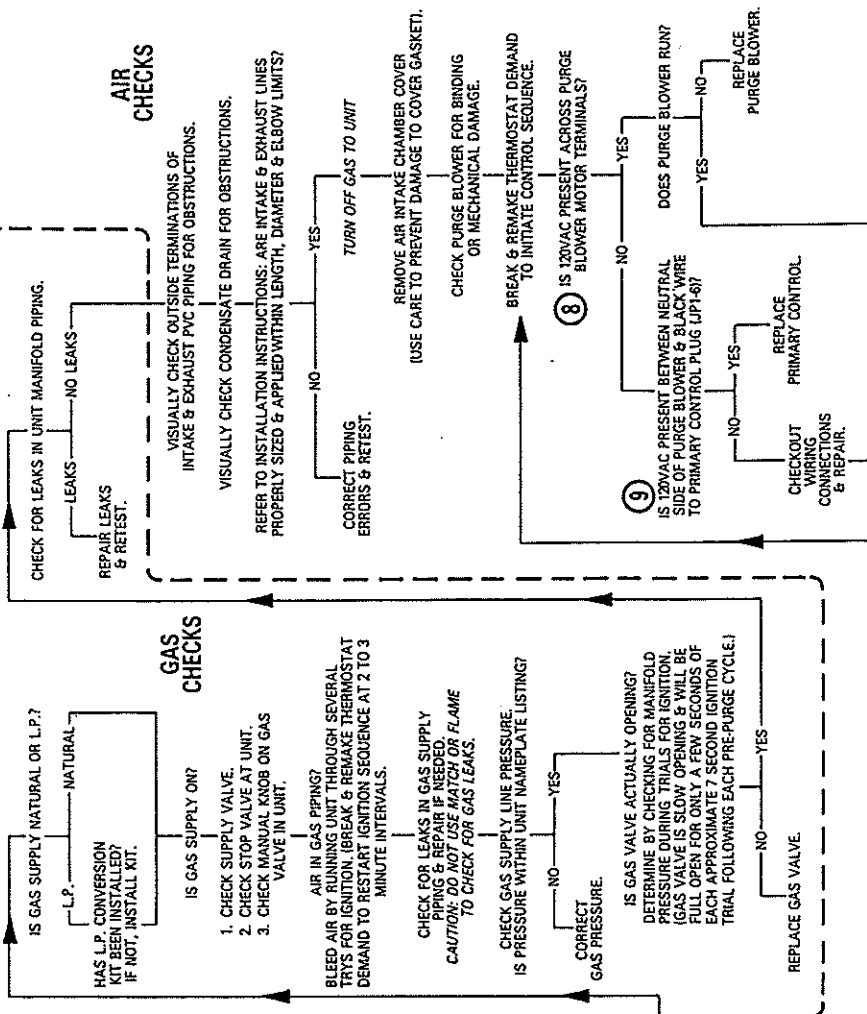
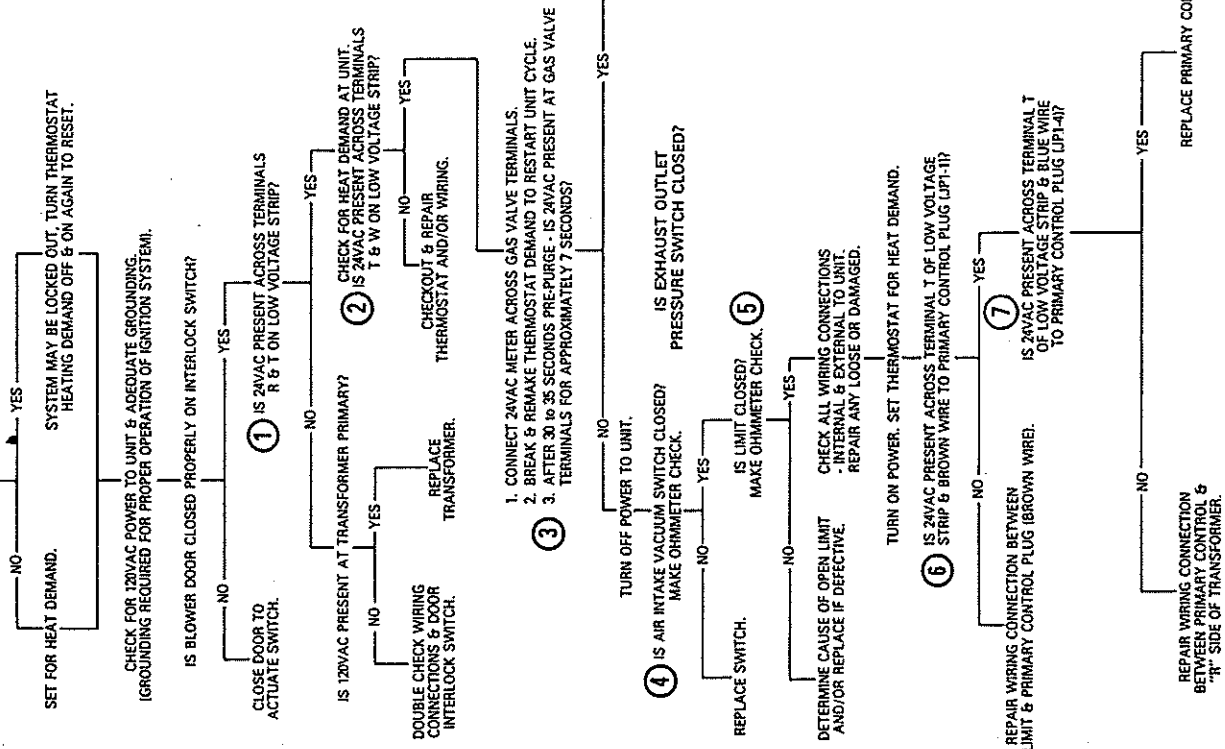

# TROUBLESHOOTING CONT.

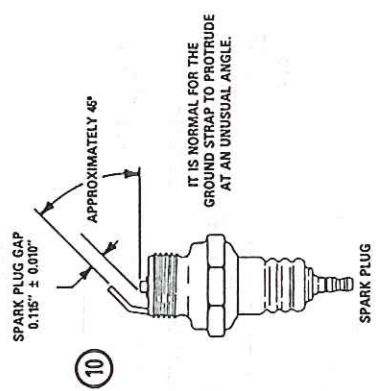
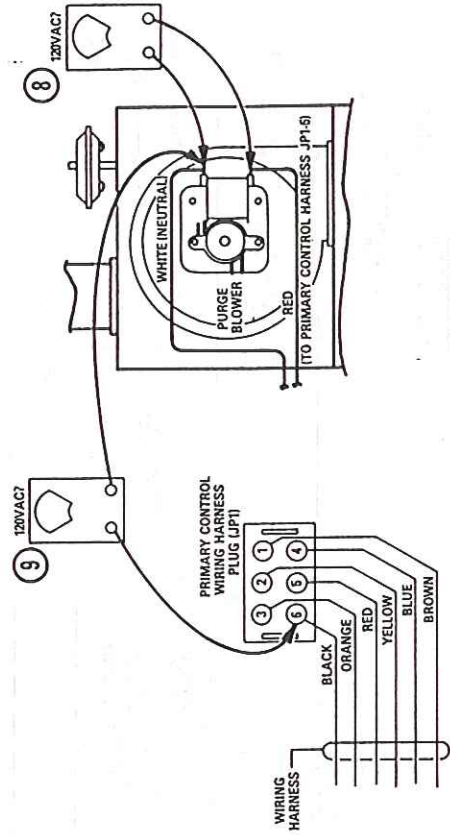
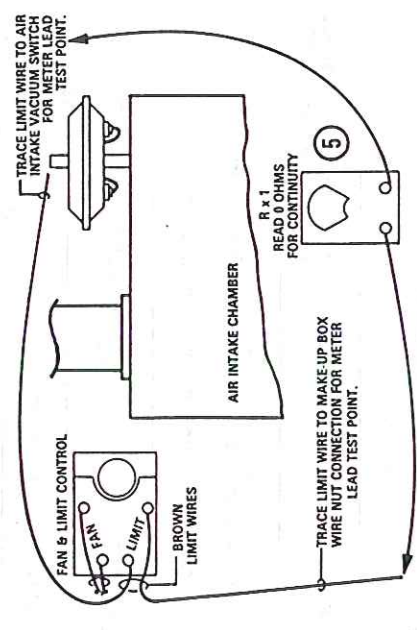
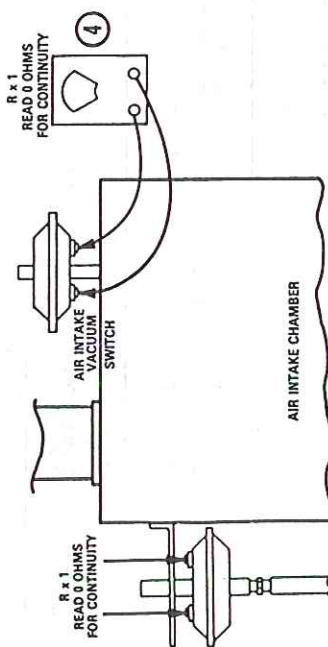
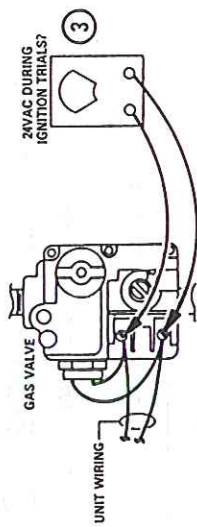
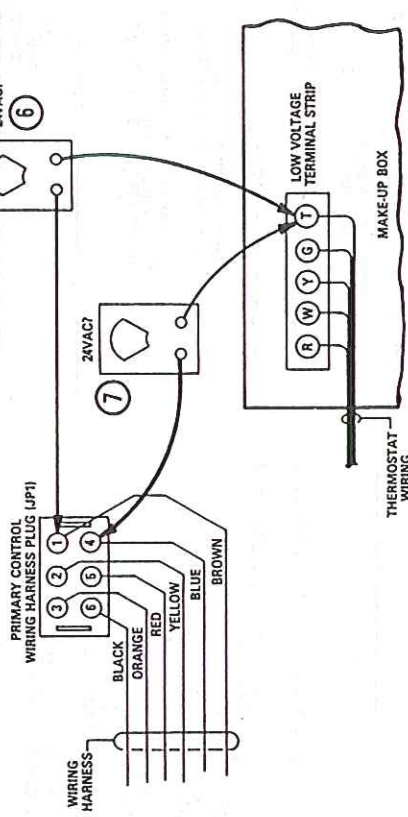

## G14 TROUBLESHOOTING - UNIT WILL NOT RUN

NOTE: CHECKS ILLUSTRATED CORRESPOND TO G14 TROUBLESHOOTING FLOW CHART ON OPPOSITE PAGE.

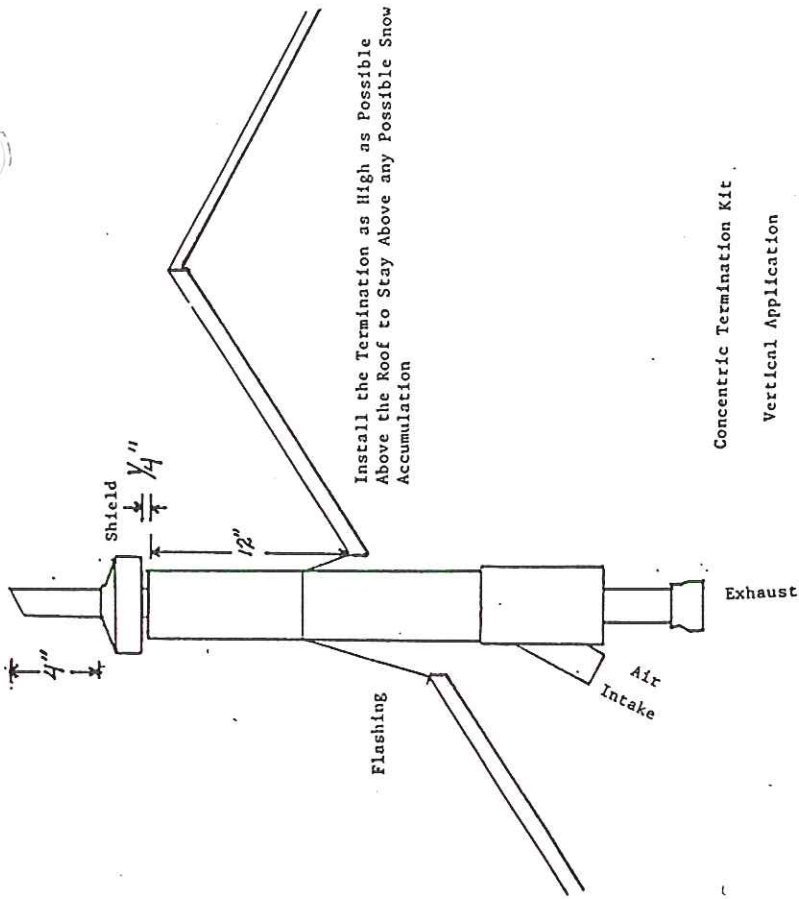

Install the Termination as High as Possible Above the Roof to Stay Above any Possible Snow Accumulation

Concentric Termination Kit  
Vertical Application

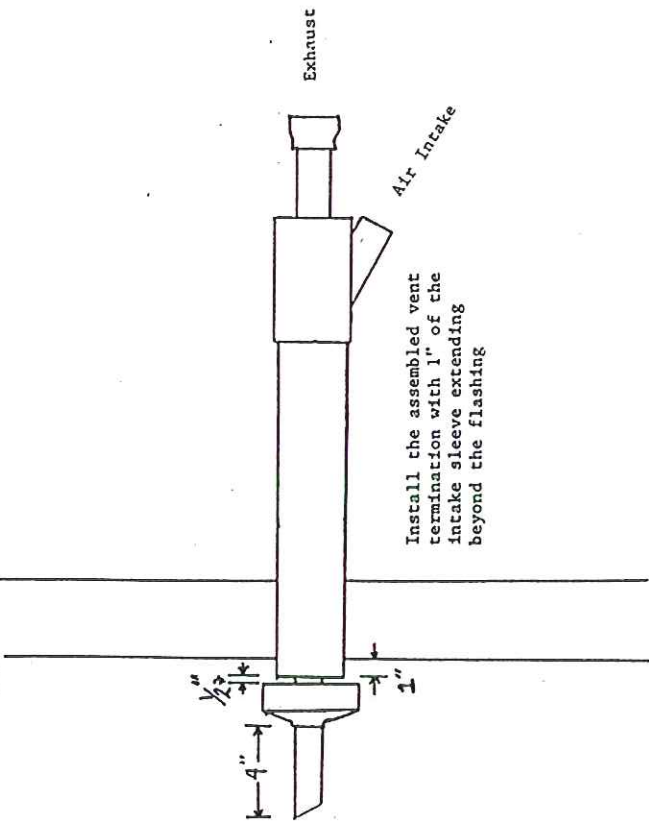
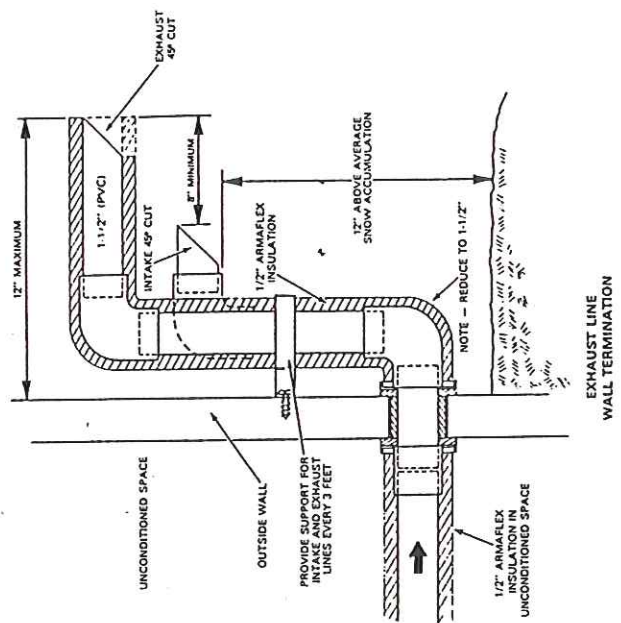

Concentric Termination Kit  
Horizontal Application

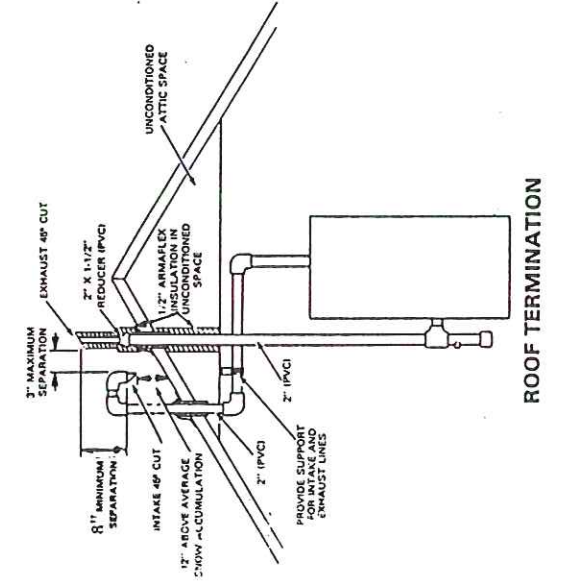
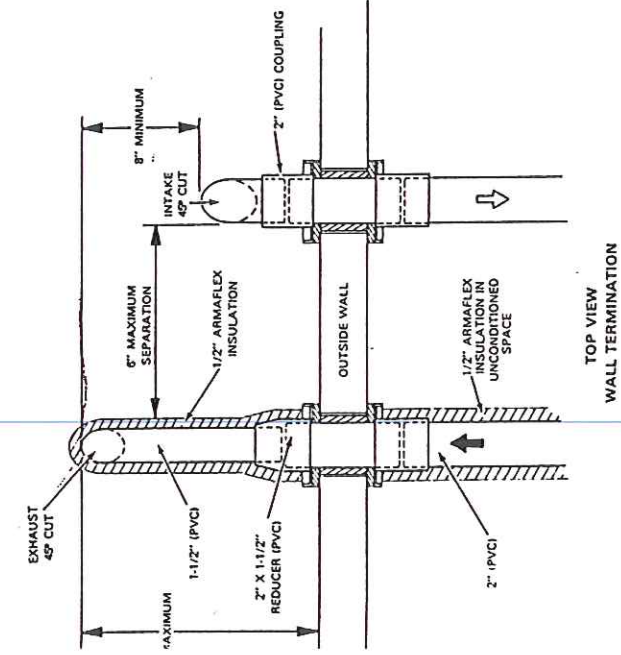



# Lennox Industries Inc.

2651 S. 600 W.  
Salt Lake City, UT 84115  
801-973-8889  
Fax: 801-973-8187

## FAX TRANSMISSION COVER SHEET

Date: 30 April 1997

To: Mike Jaynes.

Fax: 324-3323

Subject: Cooperator Lennox Pulse inspection Program

Sender: David Dahl

YOU SHOULD RECEIVE 3 PAGE(S), INCLUDING THIS COVER SHEET.  
IF YOU DO NOT RECEIVE ALL THE PAGES, PLEASE CALL 801-973-8889.

Mike -

Here's the dealer letter we talked about - You may show it to those you think need advance info - I'm not comfortable w/ mass duplication - Some aspects such as the dealer compensation, etc. may be sensitive -

I have no problem w/ Blain Rice, Kevin Beckstead, Dan Hanson, etc seeing the letter - ~~was~~ more concerned with it being widely circulated and perhaps ending up at a competitor, etc by accident. Use your best judgement -

David Dahl





### Your Part in the Program

1. Search your records for owners of Pulse furnaces installed before January, 1990, that you installed or have serviced. Send lists or electronic files including the owner's name, address, zip code, daytime phone number, model number, and serial number (if available), and if known, the installing dealer, the installation date, and indicate whether the customer is the original owner. This information should be sent to:

Lennox Industries  
Pulse Furnace Inspection Program  
P.O. Box 799900  
Dallas, Texas 75379-9900

Or fax the information to: 1-800-381-7994

2. Perform the seventeen point Pulse service check, visual inspection and complete pressure test.
3. Return any heat exchangers that need to be replaced and fill out a one-page form to document your work.

### Lennox' Part in the Program

1. Create awareness of the inspection program.
2. Communicate with owners to advise them how to participate.
3. Reimburse you \$90 for each inspection.
4. Supply freight pre-paid replacement for any heat exchanger that needs to be replaced (and pay for return shipment of old heat exchanger).
5. Provide a \$250 labor allowance for each upflow heat exchanger replaced.
6. Provide a \$400 labor allowance for each horizontal downflow heat exchanger replaced.
7. If an eligible owner whose furnace is found to have a heat exchanger that needs replacing chooses, Lennox will supply a new Lennox furnace at a reduced cost.

While we are unable to predict the level of response to this program, we recognize that some dealers may find themselves having to handle a large number of requests in a short period of time. If this is the case, the opportunity to complete a large number of subsidized service checks should encourage you to increase your ability to perform these inspections without reducing your normal service and installation capabilities. Again, your Territory Manager will be in touch with you soon with complete details. Thank you for your cooperation.

Sincerely,

Bob Schjerven

