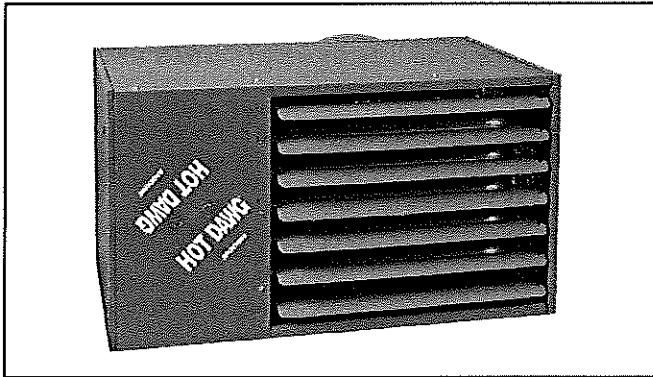


## INSTALLATION AND SERVICE MANUAL gas-fired unit heaters model HD and HDB



All models approved for use in California by the CEC, in New York city by the MEA division, and in Massachusetts. Unit heater is certified for residential and commercial applications.

### FOR YOUR SAFETY

The use and storage of gasoline or other flammable vapors and liquids in open containers in the vicinity of this appliance is hazardous.

### ! WARNING

1. Improper installation, adjustment, alteration, service, or maintenance can cause property damage, injury, or death, and could cause exposure to substances which have been determined by various state agencies to cause cancer, birth defects, or other reproductive harm. Read the installation, operating, and maintenance instructions thoroughly before installing or servicing this equipment.
2. Do not locate ANY gas-fired units in areas where chlorinated, halogenated, or acid vapors are present in the atmosphere. These substances can cause premature heat exchanger failure due to corrosion, which can cause property damage, serious injury, or death.

### IMPORTANT

The use of this manual is specifically intended for a qualified installation and service agency. All installation and service of these units must be performed by a qualified installation and service agency.

### FOR YOUR SAFETY

#### WHAT TO DO IF YOU SMELL GAS:

1. Open windows.
2. Do not try to light any appliance.
3. Do not touch any electrical switch; do not use any phone in your building.
4. Immediately call your gas supplier from a neighbor's phone. Follow the gas supplier's instructions. If you can not reach your gas supplier, call your fire department.

#### Inspection on Arrival

1. Inspect unit upon arrival. In case of damage, report it immediately to the transportation company and your local Modine sales representative.
2. Check rating plate on unit to verify that power supply meets available electric power at the point of installation.
3. Inspect unit upon arrival for conformance with description of product ordered (including specifications where applicable).

#### Table of Contents

Inspection on Arrival . . . . .	1
Special Precautions . . . . .	2
SI (Metric) Conversion Factors . . . . .	3
Before You Begin . . . . .	3
Unit Location . . . . .	4
Combustible Material and Service Clearances . . . . .	4
Unit Mounting . . . . .	5
Unit Installation . . . . .	5
Venting . . . . .	6
Gas Connections . . . . .	12
Wiring/Blower Speed Adjustment . . . . .	13
Operation . . . . .	14
Unit Components . . . . .	15
Dimensions . . . . .	16
Service/Troubleshooting . . . . .	17
Unit Wiring Diagram . . . . .	18
Serial/Model Number/Replacement Parts . . . . .	19
Commercial Warranty . . . . .	20

## SPECIAL PRECAUTIONS

### SPECIAL PRECAUTIONS

THE INSTALLATION AND MAINTENANCE INSTRUCTIONS IN THIS MANUAL MUST BE FOLLOWED TO PROVIDE SAFE, EFFICIENT, AND TROUBLE-FREE OPERATION. IN ADDITION, PARTICULAR CARE MUST BE EXERCISED REGARDING THE SPECIAL PRECAUTIONS LISTED BELOW. FAILURE TO PROPERLY ADDRESS THESE CRITICAL AREAS COULD RESULT IN PROPERTY DAMAGE OR LOSS, PERSONAL INJURY, OR DEATH. THESE INSTRUCTIONS SUBJECT TO ANY MORE RESTRICTIVE LOCAL OR NATIONAL CODES.

#### HAZARD INTENSITY LEVELS

1. **DANGER:** Indicates an imminently hazardous situation which, if not avoided, WILL result in death or serious injury.
2. **WARNING:** Indicates a potentially hazardous situation which, if not avoided, COULD result in death or serious injury.
3. **CAUTION:** Indicates a potentially hazardous situation which, if not avoided, MAY result in minor or moderate injury.
4. **IMPORTANT:** Indicates a situation which, if not avoided, MAY result in a potential safety concern.

### DANGER

Appliances must not be installed where they may be exposed to a potentially explosive or flammable atmosphere.

### WARNING

1. Gas fired heating equipment must be vented - do not operate unvented.
2. A built-in power exhauster is provided - additional external power exhausters are not required or permitted.
3. If you are replacing an existing heater, it may be necessary to resize the venting systems. Improperly sized venting systems can result in vent gas leakage or the formation of condensate. Refer to the National Fuel Gas Code ANSI Z223.1 (NFPA 54) or CSA-B149.1 - latest edition. Failure to follow these instructions can result in injury or death.
4. Under no circumstances should two sections of double wall vent pipe be joined together within one horizontal vent system due to the inability to verify complete seal of inner pipes.
5. All field gas piping must be pressure/leak tested prior to operation. Never use an open flame. Use a soap solution or equivalent for testing.
6. Gas pressure to appliance controls must never exceed 14" W.C. (1/2 psi).
7. To reduce the opportunity for condensation, the minimum sea level input to the appliance, as indicated on the serial plate, must not be less than 5% below the rated input, or 5% below the minimum rated input of dual rated units.
8. Disconnect power supply before making wiring connections to prevent electrical shock and equipment damage.
9. All appliances must be wired strictly in accordance with wiring diagram furnished with the appliance. Any wiring different from the wiring diagram could result in a hazard to persons and property.
10. Any original factory wiring that requires replacement must be replaced with wiring material having a temperature rating of at least 105°C.
11. Ensure that the supply voltage to the appliance, as indicated on the serial plate, is not 5% greater than the rated voltage.
12. When servicing or repairing this equipment, use only factory-approved service replacement parts. A complete replacements parts list may be obtained by contacting the factory. Refer to the rating plate on the appliance for complete appliance model number, serial number, and company address. Any substitution of parts or controls not approved by the factory will be at the owners risk.

### CAUTION

1. All literature shipped with this unit should be kept for future use for servicing or service diagnostics. Do not discard any literature shipped with this unit.
2. Consult piping, electrical, and venting instructions in this manual before final installation.
3. Do not attach ductwork, air filters, or polytubes to any propeller unit heater.
4. Clearances to combustible materials are critical. Be sure to follow all listed requirements.
5. Do not locate units in tightly sealed rooms or small compartments (commonly referred to as confined spaces) without provisions for adequate combustion air and venting. Combustion air must have access to the confined space through a minimum of two permanent openings in the enclosure, at least one near the bottom. They should provide a free area of one square inch per 1,000 BTU/Hr input rating of the unit with a minimum of 100 square inches for each opening, whichever is greater.
6. Low profile heaters are designed for use in heating applications with ambient temperatures between -40°F and 90°F.
7. Do not install unit outdoors.
8. In garages or other sections of aircraft hangars, such as offices and shops that communicate with areas used for servicing or storage, keep the bottom of the unit at least 7' above the floor unless the unit is properly guarded to provide user protection from moving parts. In parking garages, the unit must be installed in accordance with the standard for parking structures ANSI/NFPA 88A, and in repair garages the standard for repair garages NFPA #88B. In Canada, installation of heaters in airplane hangars must be in accordance with the requirements of the enforcing authority, and in public garages in accordance with the current CSA-B149 codes.
9. In aircraft hangars, keep the bottom of the unit at least 10' from the highest surface of the wings or engine enclosure of the highest aircraft housed in the hangars and in accordance with the requirements of the enforcing authority and/or NFPA 409 - latest edition.
10. Installation of units in high humidity or salt water atmospheres will cause accelerated corrosion resulting in a reduction of the normal life of the units.
11. Do not install units below 7' measured from the bottom of the unit to the floor in commercial applications (unless unit is properly guarded to provide user protection from moving parts) and 5' measured from the bottom of the unit to the floor in residential applications.
12. Be sure no obstructions block air intake and discharge of unit heaters.
13. The minimum distance from combustible material is based on the combustible material surface not exceeding 160°F. Clearance from the top of the unit may be required to be greater than the minimum specified if heat damage, other than fire, may occur to materials above the unit heater at the temperature described.
14. Allow 18" of clearance at rear (or 6" beyond end of motor at rear of unit, whichever is greater) and access side to provide ample air for combustion and proper operation of fan.
15. Installation must conform with local building codes or in the absence of local codes, with Part 7, Venting of Equipment, of the National Fuel Gas Code, ANSI Z223.1 (NFPA 54) - latest edition. In Canada, installation must be in accordance with CSA-B149.1.
16. Purging of air from gas supply line should be performed as described in the National Fuel Gas Code, ANSI Z223.1 (NFPA 54) - latest edition. In Canada, installation must be in accordance with CSA-B149.1.

## SPECIAL PRECAUTIONS / SI (METRIC) CONVERSION FACTORS

### ⚠ CAUTION

17. When leak testing the gas supply piping system, the appliance and its combination gas control must be isolated during any pressure testing in excess of 14" W.C. (1/2 psi).
18. The unit should be isolated from the gas supply piping system by closing its field installed manual shut-off valve. This manual shut-off valve should be located within 6' of the heater.
19. Turn off all gas before installing appliance.
20. Ensure that the supply voltage to the appliance, as indicated on the serial plate, is less than 5% below the rated voltage.
21. Check the gas inlet pressure at the unit upstream of the combination gas control. The inlet pressure should be 6-7" W.C. on natural gas or 12-14" W.C. on propane. If inlet pressure is too high, install an additional pressure regulator upstream of the combination gas control.
22. Service or repair of this equipment must be performed by a qualified service agency.
23. Do not attempt to reuse any mechanical or electronic ignition controllers which has been wet. Replace defective controller.

### IMPORTANT

1. To prevent premature heat exchanger failure, do not locate ANY gas-fired appliances in areas where corrosive vapors (i.e. chlorinated, halogenated, or acidic) are present in the atmosphere.
2. To prevent premature heat exchanger failure, the input to the appliance as indicated on the serial plate must not exceed the rated input by more than 5%.
3. To check most of the Possible Remedies in the troubleshooting guide listed in Table 17.1 refer to the applicable sections of the manual.

## SI (METRIC) CONVERSION FACTORS

To Convert	Multiply By	To Obtain
"W.C.	0.249	kPa
°F	$(°F-32) \times 5/9$	°C
Btu	1.06	kJ
Btu/ft <sup>3</sup>	37.3	kJ/m <sup>3</sup>
Btu/hr	0.000293	kW
CFH (ft <sup>3</sup> /hr)	0.000472	m <sup>3</sup> /min
CFH (ft <sup>3</sup> /hr)	0.00000787	m <sup>3</sup> /s
CFM (ft <sup>3</sup> /min)	0.0283	m <sup>3</sup> /min
CFM (ft <sup>3</sup> /min)	0.000472	m <sup>3</sup> /s

To Convert	Multiply By	To Obtain
feet	0.305	m
Gal/Hr.	0.00379	m <sup>3</sup> /hr
Gal/Hr.	3.79	l/hr
gallons	3.79	l
Horsepower	746	W
inches	25.4	mm
pound	0.454	kg
psig	6.89	kPa
psig	27.7	"W.C.

## BEFORE YOU BEGIN

### ⚠ CAUTION

1. All literature shipped with this unit should be kept for future use for servicing or service diagnostics. Leave manual with the owner. Do not discard any literature shipped with this unit.
2. Consult piping, electrical, and venting instructions in this manual before final installation.
3. Do not attach ductwork, air filters, or polytubes to any propeller unit heater.

In the U.S., the installation of these units must comply with the National Fuel Gas Code, ANSI Z223.1 - latest edition (also known as NFPA 54) and other applicable local building codes. In Canada, the installation of these units must comply with local plumbing or waste water codes and other applicable codes and with the current code CSA-B149.1.

1. All installation and service of these units must be performed by a qualified installation and service agency only as defined in ANSI Z223.1 (NFPA 54) - latest edition, or in Canada by a licensed gas fitter.
2. This unit is certified with the controls furnished. For replacements parts, please order according to the replacement parts list on serial plate. Always know your model and serial numbers. Modine reserves the right to substitute other authorized controls as replacements.
3. Unit is balanced for correct performance. Do not alter fan or operate motors at reduced speed.
4. Information on controls is supplied separately.
5. The same burner is used for natural and propane gas.

## UNIT LOCATION

### UNIT LOCATION

#### **DANGER**

Appliances must not be installed where they may be exposed to a potentially explosive or flammable atmosphere.

#### **CAUTION**

1. Clearances to combustible materials are critical. Be sure to follow all listed requirements.
2. Do not locate units in tightly sealed rooms or small compartments (commonly referred to as confined spaces) without provisions for adequate combustion air and venting. Combustion air must have access to the confined space through a minimum of two permanent openings in the enclosure, at least one near the bottom. They should provide a free area of one square inch per 1,000 BTU/Hr input rating of the unit with a minimum of 100 square inches for each opening, whichever is greater.
3. Low profile heaters are designed for use in heating applications with ambient temperatures between -40°F and 90°F.
4. Do not install unit outdoors.
5. In garages or other sections of aircraft hangars such as offices and shops that communicate with areas used for servicing or storage, keep the bottom of the unit at least 7' above the floor unless the unit is properly guarded. In parking garages, the unit must be installed in accordance with the standard for parking structures ANSI/NFPA 88A, and in repair garages the standard for repair garages NFPA #88B. In Canada, installation of heaters in airplane hangars must be in accordance with the requirements of the enforcing authority, and in public garages in accordance with the current CSA-B149 codes.
6. In aircraft hangars, keep the bottom of the unit at least 10' from the highest surface of the wings or engine enclosure of the highest aircraft housed in the hangars and in accordance with the requirements of the enforcing authority and/or NFPA 409 - latest edition.
7. Installation of units in high humidity or salt water atmospheres will cause accelerated corrosion resulting in a reduction of the normal life of the units.

#### **IMPORTANT**

To prevent premature heat exchanger failure, do not locate ANY gas-fired appliances in areas where corrosive vapors (i.e. chlorinated, halogenated or acid) are present in the atmosphere.

#### Location Recommendations

1. When locating the heater, consider general space and heating requirements, availability of gas and electrical supply, and proximity to vent locations.
2. When locating units, it is important to consider that the exhaust vent piping must be connected to the outside atmosphere.
3. Be sure the structural support at the unit location site is adequate to support the unit's weight. For proper operation the unit must be installed in a level horizontal position.
4. Do not install units in locations where the flue products can be drawn into the adjacent building openings such as windows, fresh air intakes, etc.
5. Be sure that the minimum clearances to combustible materials and recommended service clearances are maintained. Units are designed for installation with the minimum clearances as shown in Table 4.1.

Table 4.1 Clearances

Unit Side	Clearance To Combustible Materials	Recommended Service Clearance
Top and Bottom	1"	1"
Access Side	18"	18"
Non-Access Side	1"	1"
Rear	18"	18"
Vent Connector	4"	4"

6. Do not install units in locations where the gas ignition system is exposed to water spray, rain, or dripping water.
7. Mounting Height (measured from bottom of unit) at which unit heaters are installed is critical. Refer to mounting height and heat throw data on page 15 of this manual. The maximum mounting height for any unit is that height above which the unit will not deliver heated air to the floor.

#### Combustion Air Requirements

The National Fuel Gas Code defines an "unconfined space" as a space whose volume is greater than 50 cubic feet per 1,000 Btu/Hr input of the installed appliance(s). A confined space is 50 cubic feet or less per 1,000 Btu/Hr input of the installed appliance(s).

It is not recommended to install these unit heaters into residential confined spaces. This recommendation is due to the concern that at some point in time, the combustion air openings provided by the installer may become blocked or eliminated by the owner, either intentionally or unintentionally. Despite this recommendation, if these units are installed into a residential confined space, see National Fuel Gas Code ANSI Z223.1 (NFPA 54) or CSA-B149.1 Installation Code - latest edition, for detailed combustion air provisions. The installation must adhere to these requirements.

Units installed in confined spaces in industrial/commercial installations must be provided with two permanent openings - one near the top and one near the bottom of the confined space. Each opening should have a free area of not less than one square inch per 1,000 Btu/Hr of the total input rating of all units in the confined space, freely communicating with interior areas that have adequate infiltration from the outside.

For further details on supplying combustion air to a confined (tightly sealed) space or unconfined space, see the National Fuel Gas Code ANSI Z223.1 (NFPA 54) or CSA-B149.1 Installation Code - latest edition.

#### Turning The Unit 180° (Model Sizes 30-75 Only)

All units are produced at the factory with left-side controls (when looking at the unit). If the installation requires the controls to be on the right side, all heaters - with the exception of the HD/HDB 100 and 125 - can be turned over by following the instructions below.

- By turning the unit 180° from the way it was received from the factory, the sides become opposite, but the front and back remain in the same relative position. The bottom panel now becomes the top panel and vice-versa.
- Remove the access panel, turn it 180°, and re-attach it to the unit so that all the information labels can be read.
- Remove the spring loaded deflector blades, turn them over, replace, and adjust so they are open and in a position to direct the heated air down to the floor.

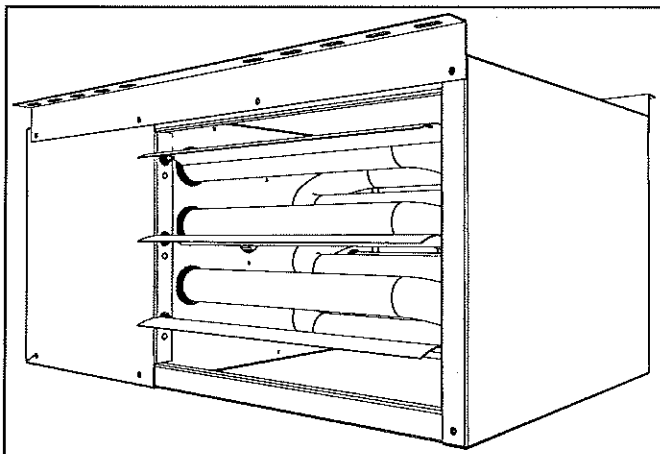
## UNIT MOUNTING

### ⚠ CAUTION

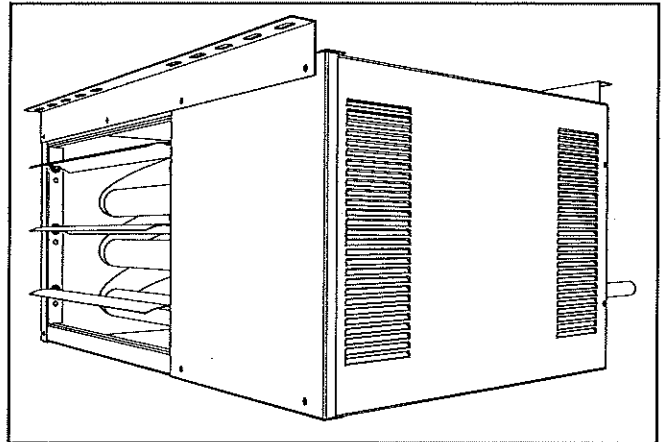
1. Do not install units below 7' measured from the bottom of the unit to the floor in commercial applications (unless unit is properly guarded to provide user protection from moving parts) and 5' measured from the bottom of the unit to the floor in residential applications.
2. Be sure no obstructions block air intake and discharge of unit heaters.
3. The minimum distance from combustible material is based on the combustible material surface not exceeding 160°F. Clearance from the top of the unit may be required to be greater than the minimum specified if heat damage, other than fire, may occur to materials above the unit heater at the temperature described.
4. Allow 18" clearance at rear (or 6" beyond end of motor at rear of unit, whichever is greater) and access side to provide ample air for combustion and proper operation of fan.

1. Be sure the means of suspension is adequate to support the weight of the unit (see page 16 for unit weights).
2. For proper operation, the unit must be installed in a level horizontal position.
3. Clearances to combustibles as previously specified must be strictly maintained.
4. For model sizes 30-75, before lifting the heater for suspension, the mounting brackets must be installed as follows (for bracket accessory installation on model sizes 100-125, see the latest revision of literature 6-594):
  - For standard (left side) control access, remove the (3) screws and mounting bracket along the top edge of both the front and back of the unit. Install the front bracket as shown in Figure 5.1 by aligning the screw holes on the bracket with the screw holes on the top edge of the unit. Repeat for the bracket on the back of the unit.
  - For right side control access, remove the (3) screws and mounting bracket along the top edge of both the front and back of the unit. Turn the unit over and install the front bracket as shown in Figure 5.2 by aligning the screw holes on the bracket with the screw holes on the top edge of the unit (originally the bottom edge). Repeat for the bracket on the back of the unit.
- 5a. **Suspension by screws/lag bolts:** Secure the mounting brackets to the ceiling joists or truss, using 1/4" screws with 1/2" washers. These unit mounting brackets are slotted to accommodate joists on 16" or 24" centerlines.

**Figure 5.1 - Unit Heater in Standard Mounting Configuration (30-75 Units Only)**

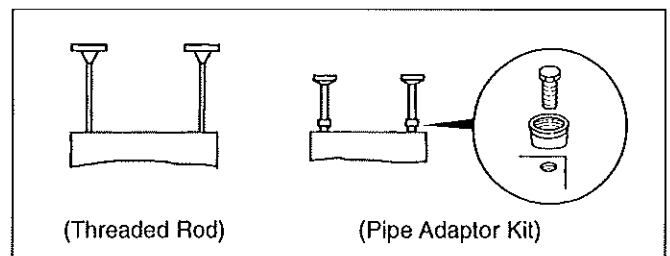


**Figure 5.2  
Unit Heater Turned 180° (30-75 units only)  
(Access panel and heated air outlet change sides)**



- 5b. **Suspension by threaded rod:** The unit can also be hung with threaded rod utilizing the same mounting brackets. Attach the threaded rod to the unit mounting brackets, securing with a top and bottom nut. For model sizes 100-125, the units are designed to be suspended by threaded rod without the use of brackets. On each piece of 3/8" threaded rod used, screw a nut a distance of about one inch onto the end of the threaded rods that will be screwed into the unit heater. Place a washer over the end of the threaded rod and screw the threaded rod into the unit heater weld nuts on the top of the heater at least 5 turns, and no more than 10 turns. Tighten the nut first installed onto the threaded rod to prevent the rod from turning. Next, drill holes into a steel channel or angle iron at the same centerline dimensions as those chosen for the heater being installed. The steel channels or angle iron pieces need to span and be fastened to appropriate structural members. Cut the threaded rods to the preferred length, push them through the holes in the steel channel or angle iron and secure with washers and lock nuts, lock washers and nuts, or a washer with double nut arrangement. **NOTE:** A pipe hanger adapter kit, shown in Figure 5.3, is available as an accessory. One kit consists of two drilled 3/4" IPS pipe caps and two 3/8 - 13 x 1-3/4" capscrews to facilitate threaded pipe suspension. Two kits would be required to install one unit.
- 5c. **Shelf mounted units:** The unit heater can also be installed on a shelf. The mounting brackets will need to be attached to the heater the same manner as explained in note #4, however, to mount on a shelf the brackets must go on the bottom of the heater. The brackets must be affixed to the shelf using similar screws (1/4" screw with 1/2" washer) as overhead joist or truss mounting. Be sure all clearance to combustible requirements are met.

**Figure 5.3 - Unit Heater Suspension Methods**



## INSTALLATION - VENTING

### **⚠ WARNING**

1. Gas fired heating equipment must be vented - do not operate unvented.
2. A built-in power exhauster is provided - additional external power exhausters are not required or permitted.
3. If you are replacing an existing heater, it may be necessary to resize the venting systems. Improperly sized venting systems can result in vent gas leakage or the formation of condensate. Refer to the National Fuel Gas Code ANSI Z223.1 (NFPA 54) or CSA-B149.1 Installation Code - latest edition. Failure to follow these instructions can result in serious injury or death.
4. Under no circumstances should two sections of double wall vent pipe be joined together within one horizontal vent system due to the inability to verify complete seal of inner pipes.

### **⚠ CAUTION**

Installation must conform with local building codes or in the absence of local codes, with Part 7, Venting of Equipment, of the National Fuel Gas Code, ANSI Z223.1 (NFPA 54) - latest edition. In Canada, installation must be in accordance with CSA B149.1.

Model HD/HDB unit heaters must be vented with the proper passageway as described in these instructions to convey flue gases from the unit or the vent connector to the outside atmosphere.

The venting instructions are organized in sections, based on installation type. The sections are identified as follows:

Instructions Section	Applicable Installation Instructions by Vent System Type
A	General instructions for ALL installations
B	<b>VERTICAL</b> Category I vent systems ①
C	<b>HORIZONTAL</b> Category III vent systems ①

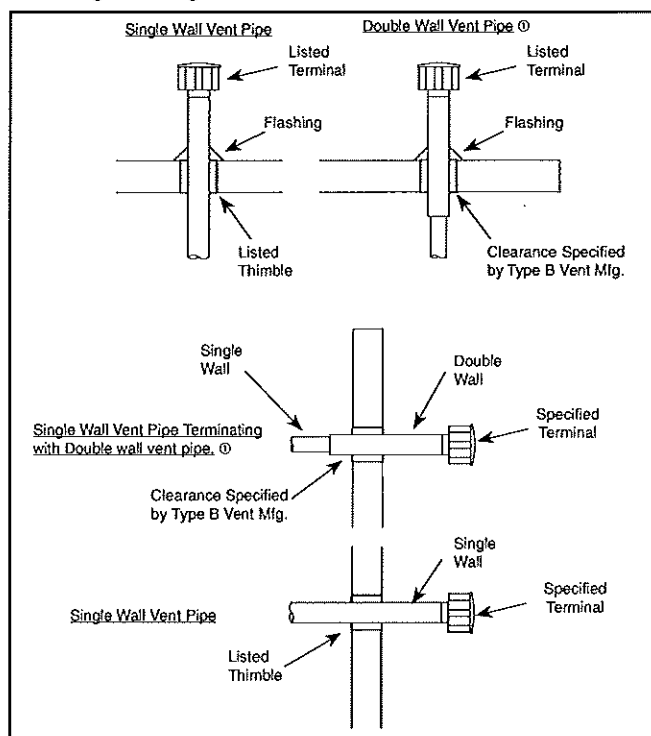
① The difference between Vertical Category I and Horizontal Category III will be identified in "Section A - General Instructions - All Units".

### Section A – General Instructions – All Units

- A1. If the unit heater being installed is replacing existing equipment and using the existing vent system from that equipment, inspect the venting system for proper size and horizontal pitch, as required in the National Fuel Gas Code ANSI Z223.1 (NFPA 54) or CSA-B149.1 Installation Code - latest edition and these instructions. Determine that there is no blockage or restriction, leakage, corrosion and other deficiencies which could cause an unsafe condition.
- A2. The vent pipe should be galvanized steel or other suitable corrosion resistant material (except for Horizontal Category III vent systems, which will be covered in "Section C – Horizontal, Category III Vent System Installation"). Follow the National Fuel Gas Code for minimum thickness of vent material. The minimum thickness for connectors varies depending on the pipe diameter. Do not vent unit with PVC or other forms of plastic venting material.
- A3. All heaters come with a factory installed vent adapter for attaching the vent pipe to the heater (3" for model sizes 30-75, 4" for model sizes 100-125). Attach the vent pipe to the adapter with 3 non-corrosive screws. (Drill pilot holes through the vent pipe and adapter prior to screwing in place).

- A4. A minimum of 12" straight pipe is recommended from the flue outlet before turns in the vent pipe.
- A5. Horizontal sections of vent pipe are to be installed with a minimum downward slope from the appliance of 1/4 inch per foot and suspended securely from overhead structures at points not greater than 3' apart.
- A6. Fasten individual lengths of vent together with at least three corrosion resistant sheet metal screws.
- A7. Keep single wall vent pipe at least 6" from combustible materials. For double wall vent pipe, follow the vent pipe manufacturer's clearances to combustibles. The minimum distance from combustible materials is based on the combustible material surface not exceeding 160°F. Clearance from the vent pipe (or the top of the unit) may be required to be greater than 6" if heat damage other than fire could result (such as material distortion or discoloration).
- A8. Avoid venting through unheated space when possible. When venting does pass through an unheated space or if the unit is installed in an environment that promotes condensation, insulate runs greater than 5' to minimize condensation. Inspect for leakage prior to insulating and use insulation that is noncombustible with a rating of not less than 400°F. Install a tee fitting at the low point of the vent system and provide a drip leg with a clean out cap as shown in Figure 8.1.
- A9. When the vent passes through a combustible INTERIOR wall or floor, a metal thimble 4" greater than the vent diameter is necessary. If there is 6' or more of vent pipe in the open space between the appliance and where the vent pipe passes through the wall or floor, the thimble need only be 2" greater than the diameter of the vent pipe. If a thimble is not used, all combustible material must be cut away to provide 6" of clearance. Where authorities have jurisdiction, type B vent may be used for the last section of vent pipe to maintain clearance to combustibles while passing through wall or floor. See Figure 6.1. Any material used to close the opening must be noncombustible.

**Figure 6.1**  
**Venting Through Combustible Roof or Wall**



① See Instruction A10 for attaching single wall pipe to double wall pipe

# INSTALLATION - VENTING

A10. The following are General Instructions for Double Wall (type B) Terminal Pipe Installation:

### How to attach a single wall vent terminal to double wall (type B) vent pipe:

1. Look for the "flow" arrow on the vent pipe.
2. Slide the vent terminal inside the exhaust end of the double wall vent pipe.
3. Drill (3) holes through the pipe and the vent terminal. Using 3/4" long sheet metal screws, attach the cap to the pipe. Do not over tighten.

### How to connect a single wall vent system to double wall (type B) vent pipe:

1. Slide the single wall pipe inside the inner wall of the double wall pipe.
2. Drill (3) holes through both walls of the single and double wall vent pipes. Using 3/4" sheet metal screws, attach the two pieces of pipe. Do not over tighten.
3. The gap between the single and double wall pipe must be sealed, but it is not necessary to fill the full volume of the annular area. To seal, run a large bead of 400°F silastic around the gap.

A11. Vent termination clearances must be maintained:

**Table 7.1 - Vent Termination Clearances**

Structure	Minimum Clearances for Vent Terminal Location
Forced air inlet within 10 feet	3 feet above
Combustion air inlet of another appliance	6 feet all directions
Door, window, gravity air inlet, or any building opening	4 feet horizontal and below 1 foot above
Electric meter, gas meter, gas regulator, and relief equipment ① Gas regulator ①	4 feet horizontal (U.S.) 6 feet horizontal (Canada) 3 feet horizontal (U.S.) 6 feet horizontal (Canada)
Adjoining building or parapet wall	6 feet all directions
Adjacent public walkways	7 feet all directions
Grade (ground level)	3 feet above ②

① Do not terminate the vent directly above a gas meter or regulator.

② The vent must be at least 6" higher than anticipated snow depth.

A12. Do NOT use dampers or other devices in the vent or combustion air pipes.

A13. Precautions must be taken to prevent degradation of building materials by flue products.

A14. Single wall vent pipe must not pass through any unoccupied attic, inside wall, concealed space, or floor.

A15. Uninsulated single wall vent pipe must not be used outdoors for venting appliances in regions where the 99% winter design temperature is below 32°F.

A16. In addition to following these General Instructions, specific instructions for Vertical Category I or Horizontal Category III vent systems must also be followed. Table 7.2 outlines the differences:

**Table 7.2 - ANSI Unit Heater Venting Requirements**

Category	Description	Venting Requirements
I	Negative vent pressure Non-condensing	Follow standard venting requirements.
II	Negative vent pressure Condensing	Condensate must be drained.
III	Positive vent pressure Non-condensing	Vent must be gas tight.
IV	Positive vent pressure Condensing	Vent must be liquid and gastight. Condensate must be drained.

Note: Vent connectors serving Category I appliances shall not be connected into any portion of mechanical draft systems operating under positive pressure.

### Vertical Category I Vent System Determination

- Vertical vent systems terminate vertically (up).
- The horizontal portion of the vent run cannot exceed 75% of the vertical rise (Example: If the vent height is 10 feet, the horizontal portion of the vent system cannot exceed 7.5 feet).
- The vent terminates a minimum of 5' above the vent connector on the unit.
- If the vent system to be installed meets ALL these criteria (an example is shown in Figure 9.1), proceed to "Section B – Vertical Vent System Installation". For all other cases, proceed to the next section for Horizontal Category III Vent System Determination:

### Horizontal Category III Vent System Determination

- Horizontal vent systems terminate horizontally (sideways).
- A vent system that terminates vertically but has a horizontal run that exceeds 75% of the vertical rise is considered horizontal.

Horizontal vent configurations are Category III. For residential installations, this requires the use of an agency approved (UL1738) Category III vent system. Additional requirements, including those for commercial and industrial installations are covered in "Section C – Horizontal, Category III Vent System Installation".

# INSTALLATION - VENTING

## Section B – Vertical Vent System Installation

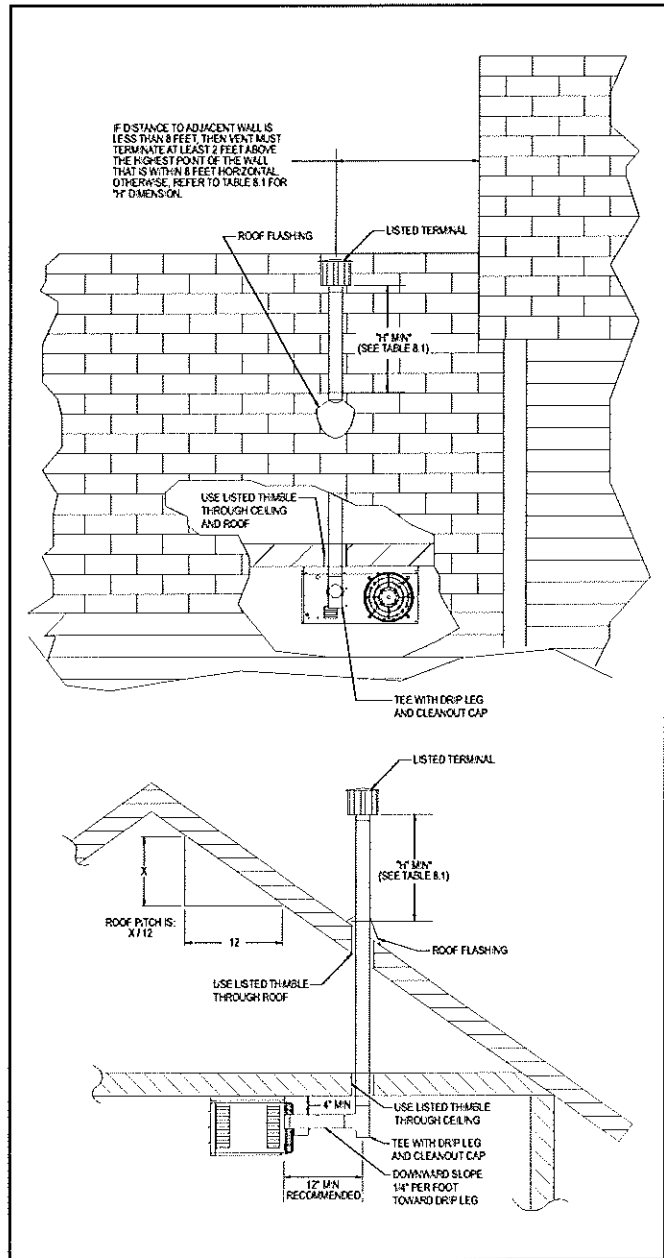
- B1. This section applies to vertically vented Category I vent systems and is in addition to "Section A – General Instructions – All Units".
- B2. Vertical vent systems terminate vertically.
- B3. The horizontal portion of the vent run cannot exceed 75% of the vertical rise (Example: If the vent height is 10 feet, the horizontal portion of the vent system cannot exceed 7.5 feet).
- B4. It is recommended to install a tee with drip leg and clean out cap as shown in Figure 8.1.
- B5. The vent terminates a minimum of 5' above the vent connector on the unit.
- B6. All vertically vented heaters that are Category I must be connected to a chimney or vent complying with a recognized standard, or a lined masonry (or concrete) chimney with a material acceptable to the authority having jurisdiction. Venting into an unlined masonry chimney is not permitted. Refer to the National Fuel Gas Code for common venting and pages 11-12 of this manual.
- B7. Use a listed vent terminal to reduce down drafts and moisture in the vent.
- B8. Double wall vent pipe is recommended, although single wall can be used if the requirements of the National Fuel Gas Code are followed.
- B9. Vertical vents must terminate a minimum horizontal and vertical distance from roof lines and adjacent walls or obstructions. These minimum distances are outlined as follows (based on National Fuel Gas Code requirements for vents with diameters less than 12"):
- For **double wall vent pipe and 8' or greater** horizontal distance to any vertical wall or similar obstruction, the vent must terminate above the roof in accordance with Figure 8.1 and Table 8.1.
  - For **double wall vent pipe and less than 8'** horizontal distance to any vertical wall or similar obstruction, the vent must terminate at least 2' above the highest point where it passes through a roof of a building and at least 2' higher than any portion of a building within a horizontal distance of 10'. See Figure 8.1.

**Table 8.1 - Minimum Height from Roof to Lowest Discharge Opening**

Rise X (in)	Roof Pitch	Min Height H (ft) ①
0-6	Flat to 6/12	1.00
6-7	6/12 to 7/12	1.25
7-8	7/12 to 8/12	1.50
8-9	8/12 to 9/12	2.00
9-10	9/12 to 10/12	2.50
10-11	10/12 to 11/12	3.25
11-12	11/12 to 12/12	4.00
12-14	12/12 to 14/12	5.00
14-16	14/12 to 16/12	6.00
16-18	16/12 to 18/12	7.00
18-20	18/12 to 20/12	7.50
20-21	20/12 to 21/12	8.00

① Size according to expected snow depth.

**Figure 8.1 - Vertical Vent Termination for Double Wall Vent Pipe and Greater Than or Less Than 8' Horizontally From a Vertical Wall or Obstruction**

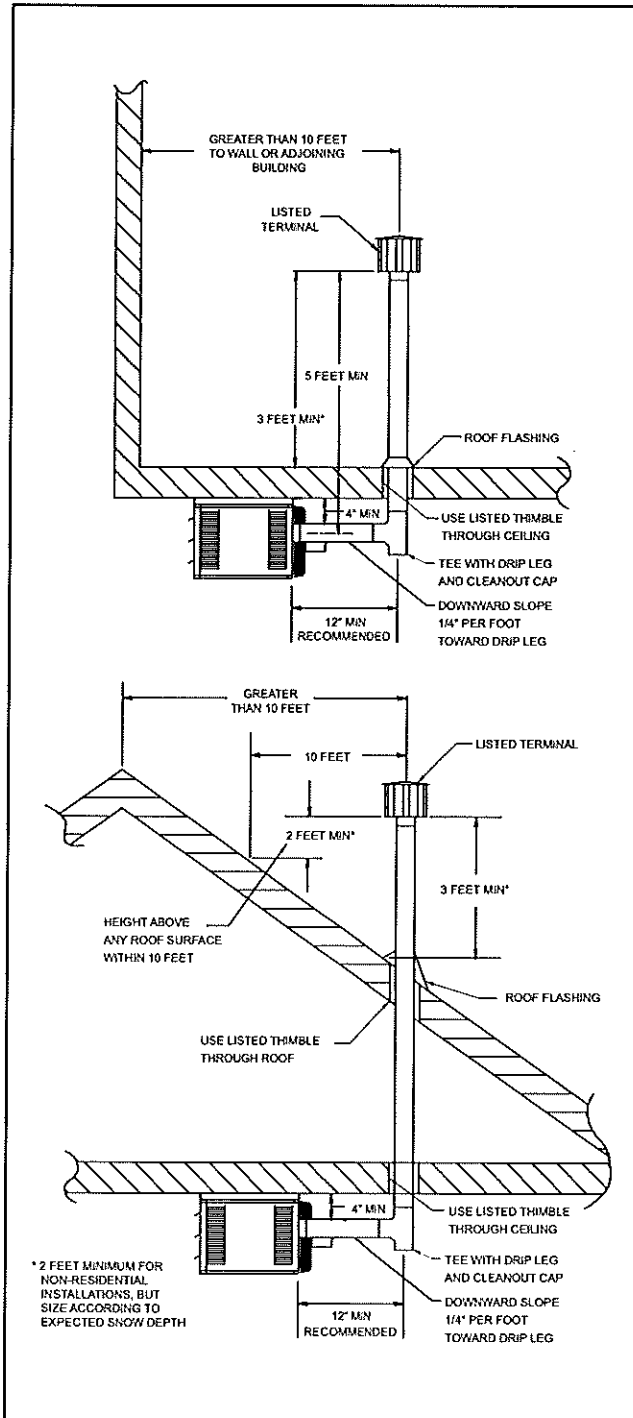




## INSTALLATION - VENTING

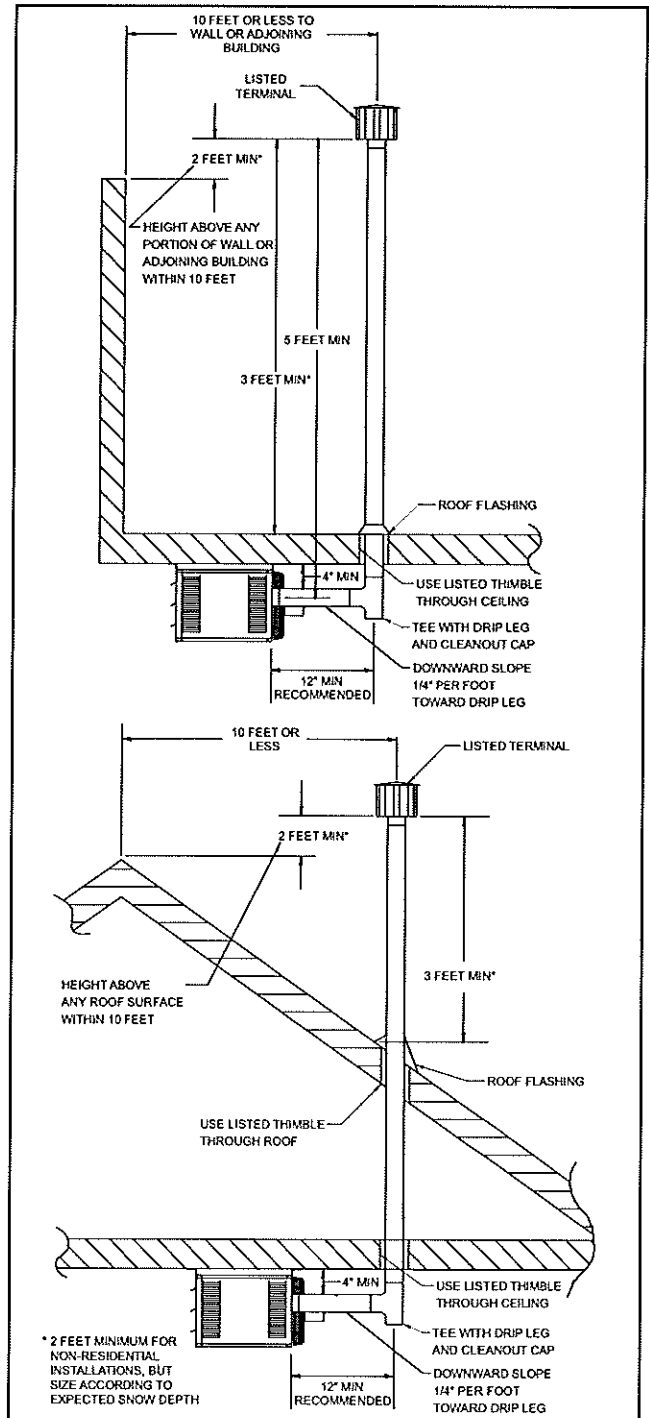
- For single wall vent pipe and 10' or greater horizontal distance to any portion of a building, the vent must terminate at least 3' (2' for non-residential installations) above the highest point where it passes through a roof of a building and at least 2' higher than any portion of a building within a horizontal distance of 10'. See Figure 9.1

**Figure 9.1 - Vertical Vent Termination for Single Wall Vent Pipe and Greater Than 10' Horizontally From Adjacent Wall or Building**



- For single wall vent pipe and less than 10' horizontal distance to any portion of a building, the vent must terminate 2' higher than any portion of that building. See Figure 9.2

**Figure 9.2 - Vertical Vent Termination for Single Wall Vent Pipe and 10' or Less Horizontally From Adjacent Building or Building**



B10. Once venting is complete, proceed to the section titled "Installation – Gas Connections".

# INSTALLATION - VENTING

## Section C – Horizontal, Category III Vent System Installation

- C1. This section applies to horizontally vented Category III vent systems and is in addition to "Section A – General Instructions – All Units".
- C2. All heaters that are horizontally vented with 3" (for sizes 30-75) or 4" (for sizes 100 and 125) vent pipe perform as a Category III appliance. Category III venting has special venting requirements as follows:
- All **residential**, horizontally vented Category III heaters must be vented with an agency certified (UL1738) Category III venting system. Agency certified Category III venting systems are available from your local vent pipe distributor. Follow the agency certified Category III vent manufacturer's instructions for installation.
  - For **commercial and industrial** horizontally vented heaters you may use either agency certified Category III venting systems as noted above, or single wall galvanized or stainless steel vent pipe. If single wall vent pipe is used, all seams and joints must be sealed with metallic tape or silastic suitable for temperatures up to 400°F. Wrap the tape two full turns around the vent pipe. For single wall vent systems, one continuous section of double wall vent pipe may be used within the vent system. Refer to instruction A10 in "Section A – General Instructions – All Units" for attaching double wall pipe to single wall pipe.
- C3. Limit the total equivalent vent pipe length to a minimum of 3' and a maximum of 30', making the vent system as straight as possible. The equivalent length of a 3" elbow is 1' and for a 4" elbow is 5'.
- C4. All horizontal Category III vents must be terminated with a Gary Steel 1092 vent cap. The cap must terminate a minimum distance from the external wall, as summarized in Table 10.1.

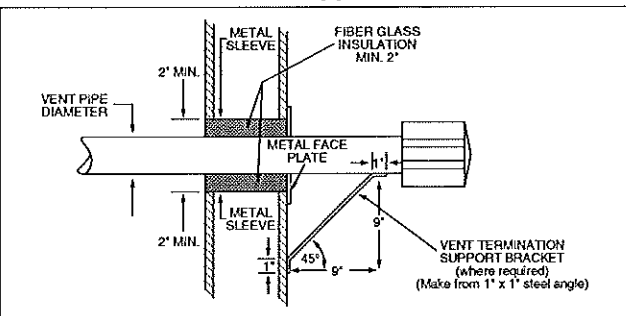
**Table 10.1 - Minimum Length Between External Wall and Vent**

Model Size	Application	Min. Length A ⓐ
30-75	Residential & Commercial	11"
100, 125	Residential	12"
100, 125	Commercial	24"

ⓐ Refer to Figure 10.2 and 10.3.

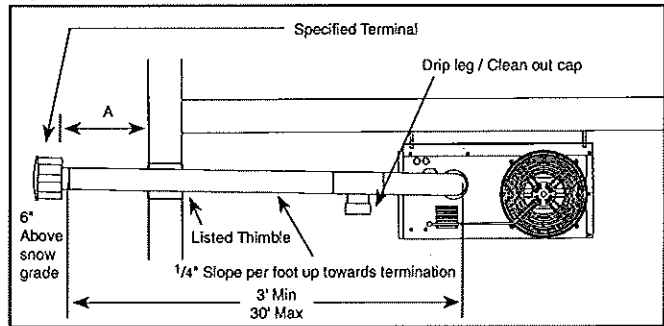
- C5. The vent must be supported as shown in Figure 10.1.

**Figure 10.1 - Exhaust Vent Construction Through Combustible Walls and Support Bracket**

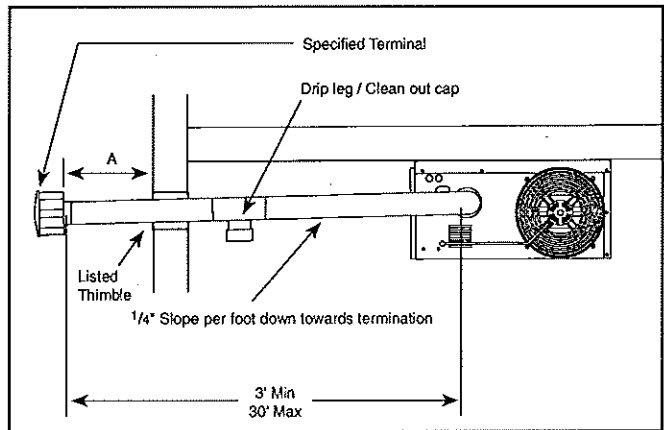


- C6. When condensation may be a problem, the vent system shall not terminate over public walkways or over an area where condensate or vapor could create a nuisance or hazard or could be detrimental to the operation of regulators, relief openings, or other equipment.
- C7. The venting system must be exclusive to a single unit, and no other unit is allowed to be vented into it.
- C8. When vented horizontally, maintain a 1/4" per foot rise away from the heater and place a drip leg with clean out near the unit as shown in Figure 10.2. Where local authorities have jurisdiction, a 1/4" per foot downward slope is acceptable with a drip leg and clean out near the exit of the vent as shown in Figure 10.3, or allow the condensate to drip out the end.

**Figure 10.2 - Horizontal Category III Venting with Upward Pitch**



**Figure 10.3 - Horizontal Category III Venting with Downward Pitch (with drip leg)**



- C9. For a vent termination located under an eave, the distance of the overhang must not exceed 24". The clearance to combustibles above the exterior vent must be maintained at a minimum of 12". Consult the National Fuel Gas Code for additional requirements for eaves that have ventilation openings.

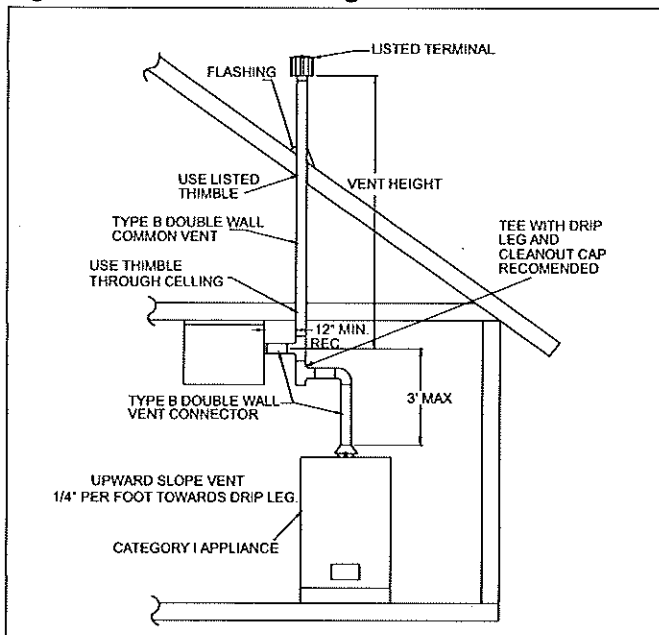
- C10. Once venting is complete, proceed to the section titled "Installation – Gas Connections".

# INSTALLATION - VENTING

## Additional Requirements for Common Venting:

1. The common vent system and all attached appliances must be Category I.
2. The vent connector should be routed in the most direct route from the units to the common vent.
3. Where two or more vent connectors enter a common gas vent or chimney flue, the smaller connector shall enter at the highest level consistent with the available head room or clearance to combustible material.
4. Restrictions within the common vent such as elbows should be minimized. Each elbow installed within the common portion of the venting system reduces maximum common vent capacity by 10% (refer to Tables 11.2 and 11.3 for capacity)
5. The vent connector capacities included in these tables allow for the use of two 90 degree elbows (or turns). For each additional elbow, the vent connector capacity shall be reduced by 10%. Refer to NFPA54/ IFEC tables for capacity ratings.
6. The common vent cross sectional area must be equal to or greater than the largest vent connector cross-sectional area.
7. If all appliances are located on one level of the building, the vent height shall be measured from the highest draft hood or vent connector to be installed within the common vent system (Refer to Figures 11.1 and 11.2).
8. All units must be vented in strict accordance of the common venting Tables 11.1 through 11.3.
9. All masonry chimneys must comply with all applicable local and national codes.
10. When combining multiple vent connectors into a manifold prior to the vertical portion of the common vent, the size of the common vent manifold and the common vent shall be determined by applying a 10% reduction (.90 x maximum vent capacity from Table 11.2 or 11.3) to the common vent capacity part of the common vent tables. The length of the common vent manifold (Lm) may not exceed 18 inches per inch of manifold diameter.
11. Refer to the National Fuel Gas Code for instructions on multi-level common venting and exterior masonry chimneys as well as additional installation of the listed applications.

**Figure 11.1 - Common Venting into Double Wall B Vent**



**Table 11.1 - Maximum Vent Connector Horizontal Run (ft) - Type B Vent Connector**

Connector Dia.	Model	Max Horiz. Run
3"	30,45,60,75	4.5
4"	100, 125	6

Based on ANSI Z223.1 (NFPA 54)-2009. For reference only.

**Table 11.2 - Maximum Total Appliance Input Capacities (MBh) - Type B Vent Connector and Type B Common Vent**

Vent Height (ft)	Diameter of Common Vent							
	4 in.		5 in.		6 in.		7 in.	
	Fan+ Fan	Fan+ Nat	Fan+ Fan	Fan+ Nat	Fan+ Fan	Fan+ Nat	Fan+ Fan	Fan+ Nat
6	92	81	140	116	204	161	309	248
8	101	90	155	129	224	178	339	275
10	110	97	169	141	243	194	367	299
15	125	112	195	164	283	228	427	352
20	136	123	215	183	314	255	475	394
30	152	138	244	210	361	297	547	459

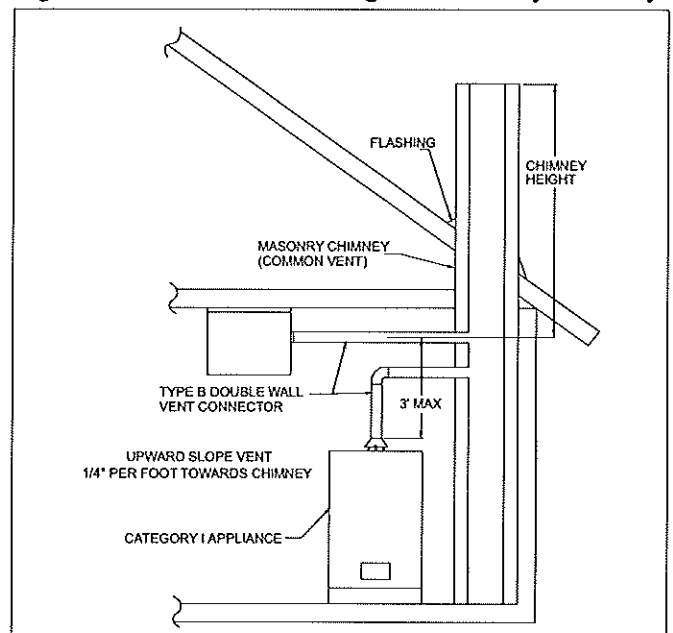
Based on ANSI Z223.1 (NFPA 54)-2009. For reference only.

**Table 11.3 - Maximum Total Appliance Input Capacities (MBh) - Type B Vent Connector with Common Vent into Masonry Chimney**

Vent Height (ft.)	Area of Common Vent							
	12 in <sup>2</sup>		19 in <sup>2</sup>		28 in <sup>2</sup>		38 in <sup>2</sup>	
	Fan+ Fan	Fan+ Nat	Fan+ Fan	Fan+ Nat	Fan+ Fan	Fan+ Nat	Fan+ Fan	Fan+ Nat
6	NA	74	NA	119	NA	178	NA	257
8	NA	80	NA	130	NA	193	NA	279
10	NA	84	NA	138	NA	207	NA	299
15	NA	NA	NA	152	NA	233	NA	334
20	NA	NA	NA	NA	NA	250	NA	368
30	NA	NA	NA	NA	NA	270	NA	404

Based on ANSI Z223.1 (NFPA 54)-2009. For reference only.

**Figure 11.2 - Common Venting into Masonry Chimney**



## INSTALLATION - GAS CONNECTIONS

### **! WARNING**

1. All field gas piping must be pressure/leak tested prior to operation. Never use an open flame. Use a soap solution or equivalent for testing.
2. Gas pressure to appliance controls must never exceed 14" W.C. (1/2 psi).
3. To reduce the opportunity for condensation, the minimum sea level input to the appliance, as indicated on the serial plate, must not be less than 5% below the rated input, or 5% below the minimum rated input of dual rated units.

### **! CAUTION**

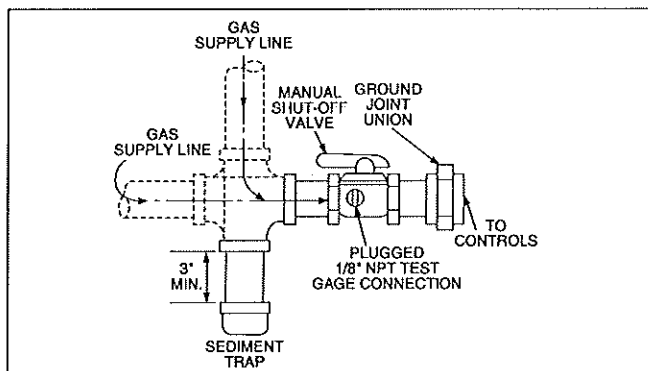
1. Purging of air from gas lines should be performed as described in the National Fuel Gas Code, ANSI Z223.1 (NFPA 54) - latest edition or in Canada CSA-B149 codes.
2. When leak testing the gas supply piping system, the appliance and its combination gas control must be isolated during any pressure testing in excess of 14" W.C. (1/2 psi).
3. The unit should be isolated from the gas supply piping system by closing its field installed manual shut-off valve. This manual shut-off valve should be located within 6' of the heater.
4. Turn off all gas before installing appliance.

### **IMPORTANT**

To prevent premature heat exchanger failure, the input to the appliance, as indicated on the serial plate, must not exceed the rated input by more than 5%.

1. Installation of piping must conform with local building codes, or in the absence of local codes, with the National Fuel Gas Code, ANSI Z223.1 (NFPA 54) - latest edition. In Canada, installation must be in accordance with CSA-B149.1.
2. Piping to units should conform with local and national requirements for type and volume of gas handled and pressure drop allowed in the line. Refer to Table 12.1 to determine the cubic feet per hour (CFH) for the type of gas and size of unit to be installed. Using this CFH value and the length of pipe necessary, determine the pipe diameter from Table 12.2. Where several units are served by the same main, the total capacity, CFH, and length of main must be considered. Avoid pipe sizes smaller than 1/2". Table 12.2 allows for a 0.3" W.C. pressure drop in the supply pressure from the building main to the unit. The inlet pressure to the unit must be 6-7" W.C. for natural gas and 11-14" W.C. for propane gas. When sizing the inlet gas pipe diameter, make sure that the unit supply pressure can be met after the 0.3" W.C. has been subtracted. If the 0.3" W.C. pressure drop is too high, refer to the Gas Engineer's Handbook for other gas pipe capacities.
3. Install a ground joint union with brass seat and a manual shut-off valve adjacent to the unit for emergency shut-off and easy servicing of controls, including a 1/8" NPT plugged tapping accessible for test gauge connection (See Figure 12.1).
4. Provide a sediment trap before each unit in the line where low spots cannot be avoided. (See Figure 12.1).
5. When Pressure/Leak testing, pressures above 14" W.C. (1/2 psi), close the field installed shut-off valve, disconnect the appliance and its combination gas control from the gas supply line, and plug the supply line before testing. When testing pressures 14" W.C. (1/2 psi) or below, close the manual shut-off valve on the appliance before testing.

Figure 12.1 - Recommended Sediment Trap/Manual Shut-off Valve Installation - Side or Bottom Gas Connection<sup>①</sup>



① Manual shut-off valve is in the "OFF" position when handle is perpendicular to pipe.

Table 12.1 - Manifold Pressure & Gas Consumption

Model Size	BTU/Cu. Ft. Specific Gravity	Natural	Propane	No. of Orifices
		1050 0.60	2500 1.53	
Manifold Pressure In. W.C.		3.5	10.0	
30	CFH	28.6	12.0	2
	Gal/Hr. Propane		.33	
	Sec/cu. ft. Orifice Drill Size	126 49	300 56	
45	CFH	42.9	18.0	3
	Gal/Hr. Propane		.50	
	Sec/cu. ft. Orifice Drill Size	84 49	200 56	
60	CFH	57.1	24.0	4
	Gal/Hr. Propane		.66	
	Sec/cu. ft. Orifice Drill Size	63 49	150 56	
75	CFH	71.4	30.0	5
	Gal/Hr. Propane		.83	
	Sec/cu. ft. Orifice Drill Size	50 49	180 56	
100	CFH	95.2	40	5
	Gal/Hr. Propane		1.09	
	Sec/cu. ft. Orifice Drill Size	38 45	90 55	
125	CFH	119	50	5
	Gal/Hr. Propane		1.37	
	Sec/cu. ft. Orifice Drill Size	30 42	72 53	

Table 12.2 - Gas Pipe Capacities - Natural Gas<sup>① ②</sup>

Pipe Length (ft)	Natural Gas					
	1/2"	3/4"	1"	1-1/4"	1-1/2"	2"
10	132	278	520	1050	1600	3050
20	92	190	350	730	1100	2100
30	73	152	285	590	890	1650
40	63	130	245	500	760	1450
50	56	115	215	440	670	1270
60	50	105	195	400	610	1150
70	46	96	180	370	560	1050
80	43	90	170	350	530	930
100	38	79	150	305	460	870
125	34	72	130	275	410	780
150	31	64	120	250	380	710

① Capacities in Cubic Feet per Hour through Schedule 40 pipe with maximum 0.3" W.C. pressure drop with up to 14" W.C. gas pressure. Specific gravity is 0.60 for Natural gas and 1.50 for Propane gas.

② For Pipe Capacity with Propane Gas, divide Natural gas capacity by 1.6. Example: What is the propane gas pipe capacity for 60 feet of 1-1/4" pipe? The Natural gas capacity is 400 CFH. Divide by 1.6 to get 250 CFH for Propane gas.

# INSTALLATION - ELECTRICAL CONNECTIONS

## ELECTRICAL CONNECTIONS

⚠ WARNING

1. Disconnect power supply before making wiring connections to prevent electrical shock and equipment damage.
2. All appliances must be wired strictly in accordance with wiring diagram furnished with the appliance. Any wiring different from the wiring diagram could result in a hazard to persons and property.
3. Any original factory wiring that requires replacement must be replaced with wiring material having a temperature rating of at least 105°C.
4. Ensure that the supply voltage to the appliance, as indicated on the serial plate, is not 5% greater than rated voltage.

⚠ CAUTION

Ensure that the supply voltage to the appliance, as indicated on the serial plate, is not 5% less than the rated voltage.

All field installed wiring must be done in accordance with the National Electrical Code ANSI/NFPA 70 – latest edition or Canadian Electrical Code CSA C22.1 Part 1 or local codes. Unit must be electrically grounded according to these codes. If any of the original wire supplied with the heater must be replaced, replace it with wiring material having a temperature rating of at least 105°C.

The power to these unit heaters should be protected with a circuit breaker.

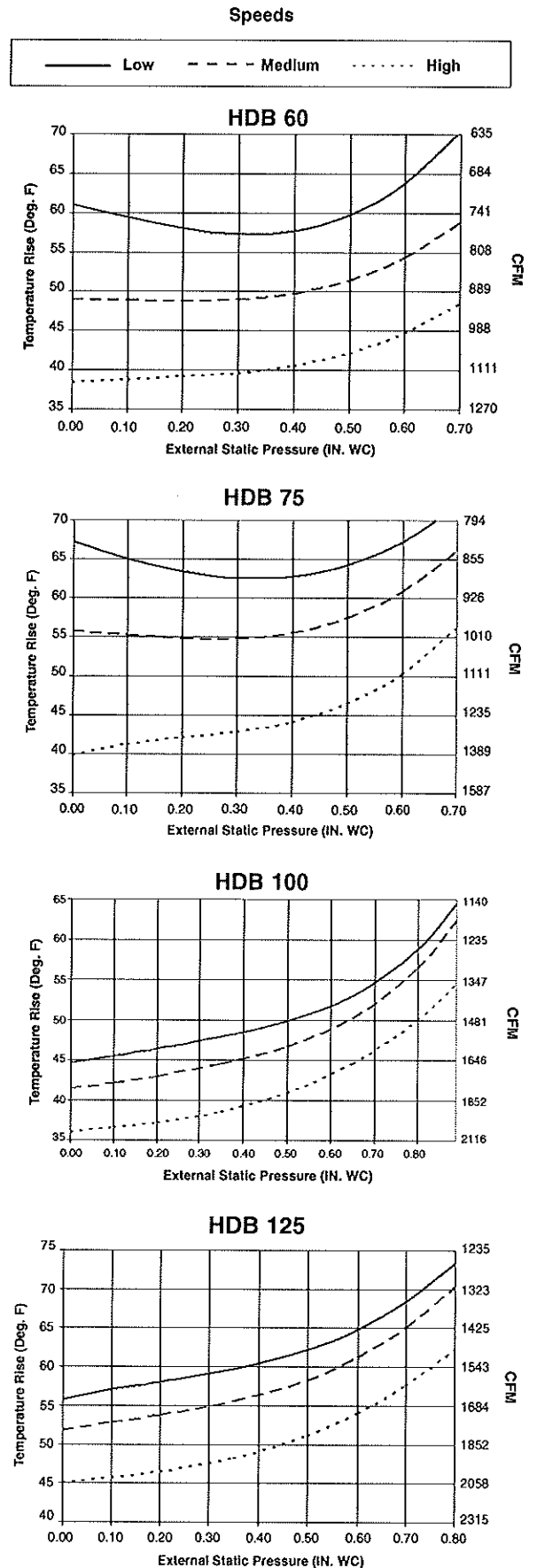
Location of thermostat should be determined by heating requirements and be mounted on an inside wall about 5' above floor level where it will not be affected by heat from the unit or other sources, or drafts from frequently opened doors. See instructions packed with thermostat.

### Wiring Adjustments for Blower Motors

The blowers used on Modine HDB units are direct drive and equipped with three speed motors. Air temperature rise of the unit is determined by the speed setting and the amount of static pressure in the system. Units are normally shipped with motors set at high speed. Motor speed is changed by connecting the motor lead for the desired fan speed to the "EAC" or "BLO" terminal of the control board. Unused motor leads for other speeds are placed on the "PARK" terminals of the board. See the wiring diagram on page 20.

When applying a blower equipped unit to a duct system or other load, consult the performance curves on this page to determine the air temperature rise for a given motor speed range and static pressure. Verify that the static pressure on the outlet of the unit does not exceed the maximum specified for the unit. If static pressure is too high it must be reduced either by modifications to the system or using the medium or low motor speed. If the unit shuts down on high limit during normal operation, a higher motor speed should be used.

## Blower Curve Models (HDB 60-125 Only)



# INSTALLATION - OPERATION

## OPERATION

### Prior to Operation

#### **IMPORTANT**

1. To prevent premature heat exchanger failure, observe heat exchanger tubes. If the bottom of the tubes become red while blower and furnace are in operation, check to be sure the blower has been set to the proper RPM for the application. Refer to page 14 for Wiring Adjustments for Blower Motors.
2. Start-up and adjustment procedures should be performed by a qualified service agency.

Although this unit has been assembled and fire-tested at the factory, the following pre-operational procedures should be performed to assure proper on-site operation.

1. Turn off power to the unit at the disconnect switch. Check that fuses or circuit breakers are in place and sized correctly. Turn all hand gas valves to the "OFF" position.
2. Remove the side control access panel.
3. Check that the supply voltage matches the unit supply voltage listed on the Model Identification plate. Verify that all wiring is secure and properly protected. Trace circuits to insure that the unit has been wired according to the wiring diagram.
4. Check to insure that the venting system is installed correctly and free from obstructions. Before you start use the following steps to verify that the venting system is adequately sized:
  - a. Seal any unused openings in the venting system.
  - b. Inspect the venting system for proper size and horizontal pitch, as required in the National Fuel Gas Code, ANSI Z223.1 (NFPA 54) or CSA B149.1 Installation Code - latest edition and these instructions. Determine that there is no blockage or restriction, leakage, corrosion and other deficiencies, which could cause an unsafe condition.
  - c. Insofar as practical, close all building doors and windows and all doors between the space in which the appliance(s) connected to the venting system are located and other spaces of the building. Turn on clothes dryers and any exhaust fans such as range hoods and bathroom exhausts, so they shall operate at maximum speed. Do not operate a summer exhaust fan. Close fireplace dampers.
  - d. Follow the lighting instructions. Place the appliance being inspected in operation. Adjust thermostat so that the appliance will operate continuously.
  - e. After it has been determined that each appliance connected to the venting system properly vents when tested as outlined above, return doors, windows, exhaust fans, fireplace dampers and any other gas-burning appliance to their previous conditions of use.
  - f. If improper venting is observed during any of the above tests, the venting system must be corrected.
5. Check to see that there are no obstructions to the intake and discharge of the unit.
6. Check fan clearance. Fan should not contact casing when spun by hand.
7. Check to make sure that all filters are in place and that they are installed properly according to direction of air flow (if applicable).
8. Perform a visual inspection of the unit to make sure no damage has occurred during installation.
9. Check that all horizontal deflector blades are open a minimum of 30° as measured from vertical.
10. Turn on power to the unit at the disconnect switch.
11. Check the thermostat, ignition control, gas valve, and supply fan blower motor for electrical operation. If these do not function, check that the wiring is per the diagram.
12. Check the blower wheel for proper direction of rotation when compared to the air flow direction arrow on the blower housing (if applicable). Blower wheel rotation, not air movement, must be checked as some air will be delivered through the unit with the blower wheel running backwards.
13. For blower units, check the blower speed (RPM). Refer to Blower Adjustments for modification.
14. Check the motor speed (RPM).
15. Check the motor voltage.
16. Check the motor amp draw to make sure it does not exceed the motor nameplate rating.
17. Recheck the gas supply pressure at the field installed manual shut-off valve. The minimum inlet pressure should be 6" W.C. on natural gas and 11" W.C. on propane gas. The maximum inlet pressure for either gas is 14" W.C. If inlet pressure exceeds 14" W.C., a gas pressure regulator must be added upstream of the combination gas valve.
18. Open the field installed manual gas shut-off valve.
19. Place the manual main gas valve on the combination gas valve in the "ON" position. Call for heat with the thermostat.
20. Check to make sure that the main gas valve opens. Check the manifold gas pressure (See Main Burner Adjustment) while the supply fan blower is operating.
21. Check to insure that gas controls sequence properly (See Control Operating Sequence). If you are not familiar with the unit's controls (i.e. combination gas control), refer to the control manufacturer's literature supplied with the unit.
22. Once proper operation of the unit has been verified, remove any jumper wires that were required for testing.
24. Replace the side control access panel.

### **Main Burner Adjustment**

The gas pressure regulator (integral to the combination gas control) is adjusted at the factory for average gas conditions. It is important that gas be supplied to the unit heater in accordance with the input rating on the serial plate. Actual input should be checked and necessary adjustments made after the unit heater is installed. Over-firing, a result of too high an input, reduces the life of the appliance and increases maintenance. Under no circumstances should the input exceed that shown on the serial plate.

Measuring the manifold pressure is done at the outlet pressure tap of the gas valve.

### **To Adjust the Manifold Pressure**

1. Move the field installed manual shut-off valve to the "OFF" position.
2. Remove the 1/8" pipe plug from the outlet pressure tap on the gas valve and attach a water manometer of "U" tube type which is at least 12" high.
3. Move the field installed manual gas shut-off valve to the "ON" position.
4. Create a high-fire call for heat from the thermostat.
5. Refer to Table 12.1 to determine the correct high fire manifold pressure for the gas type of the unit. Adjust the main gas pressure regulator spring to achieve the proper manifold pressure (for location, see the combination gas control literature supplied with unit).
6. After adjustment, move the field installed manual shut-off valve to the "OFF" position and replace the 1/8" pipe plug.
7. After the plug is in place, move the field installed manual shut-off valve to the "ON" position and recheck pipe plugs for gas leaks with soap solution.

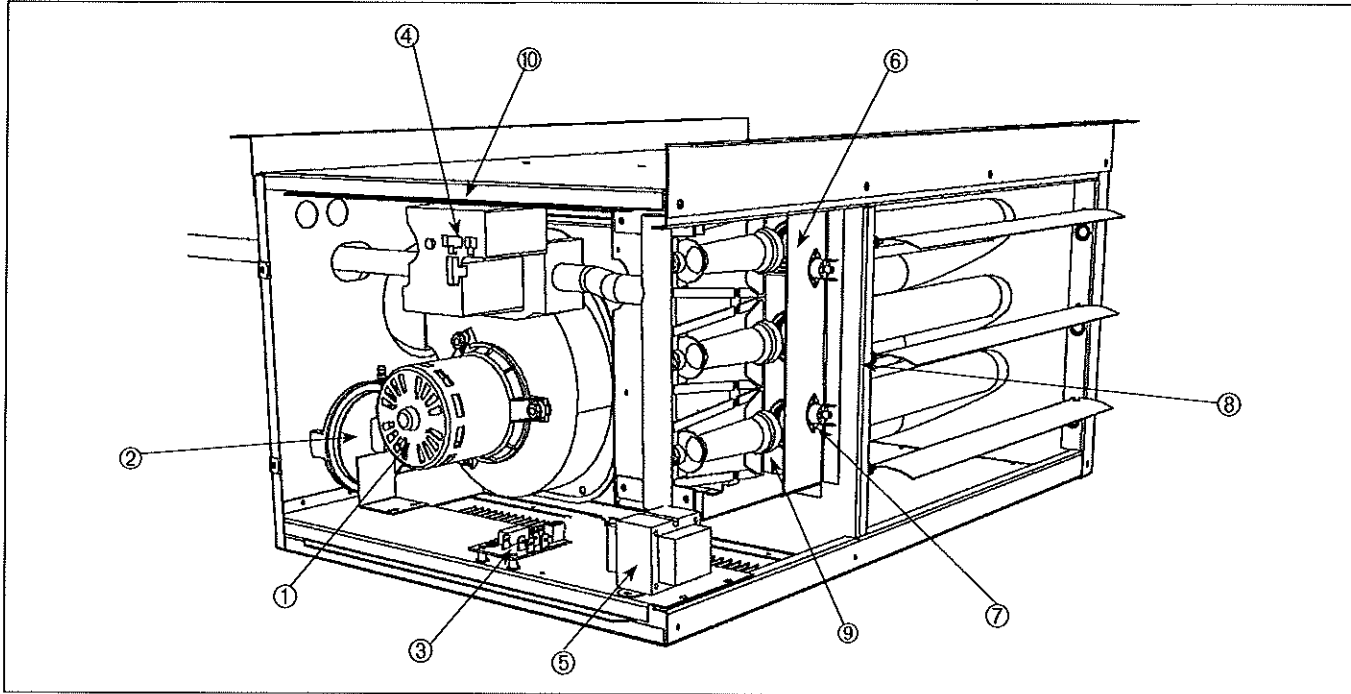
# CONTROL OPERATING SEQUENCE / UNIT COMPONENTS

## CONTROL OPERATING SEQUENCE

Upon a call for heat from the thermostat, power is supplied to the power exhauster motor. The unit will go through a purge period and then the direct spark igniter will be energized. At the same time, the main valve in the combination control valve will open to allow gas to flow to the burners. If the fan motor has

not all ready started it will start shortly. If a flame is not sensed for any reason the main valve will close and there will be a short purge period before ignition is tried again. If the flame is not sensed after four tries, there will be at least a one hour wait before ignition is tried again.

Figure 15.1 - Major Gas, Electrical Service, Safety and Other Components



- |  |                            |   |
|--|----------------------------|---|
| 1. Power Exhauster                       | 4. Combination Gas Control | 8. Auto Reset Limit Control (hidden)                      |
| 2. Pressure Switch                       | 5. Control Transformer     | 9. Direct Spark Igniter (hidden)                          |
| 3. Integrated Direct Spark Control Board | 6. Flame Sensor (hidden)   | 10. Manual Reset Control (hidden, propeller 100-125 only) |
|  | 7. Flame Rollout Switch    |   |

## Control Options

Control Description	Control Code No.	Service Voltage	Thermostat Voltage	Type of Gas	Model Size
Single-Stage, Direct Spark Ignition, 100% Shut-Off with Continuous Retry - Utilizes a single-stage combination gas control with ignition control. Gas is lit with a direct spark igniter on call for heat.	11	115V	24V	natural	30-125
	21	115V	24V	propane	30-125
Two-Stage, Direct Spark Ignition, 100% Shut-Off with Continuous Retry - Utilizes a two-stage combination gas control with built-in ignition control. Firing rate is 100% and 50% of full rated input. Gas is lit with a direct spark igniter on call for heat.	12	115V	24V	natural	75-125
	22	115V	24V	propane	75-125

## Performance - Model HD

Models	HD30	HD45	HD60	HD75	HD100	HD125	
Btu/Hr Input	30,000	45,000	60,000	75,000	100,000	125,000	
Btu/Hr Output	24,000	36,000	48,000	60,000	80,000	100,000	
Entering Airflow (CFM)	505	720	990	1,160	1,490	1,980	
Outlet Velocity	523	749	653	769	565	747	
Air Temp. Rise (°F)	44	46	45	48	50	47	
Mounting Height (Max ft.)	10	10	12	14	12	16	
Heat Throw (ft.)	25	27	36	38	42	56	
Motor Data	Horsepower	1/15	1/15	1/12	1/12	1/12	1/8
	RPM	1,550	1,550	1,625	1,625	1,050	1,550
	Type	S.P.	S.P.	P.S.C.	P.S.C.	S.P.	P.S.C.
	Amps	2.4	2.4	1.2	1.2	2.7	2.2
Unit Total Amps	3.7	3.7	2.5	2.5	4.7	4.2	

## Performance - Model HDB

Models	HDB60	HDB75	HDB100	HDB125	
Btu/Hr Input	60,000	75,000	100,000	125,000	
Btu/Hr Output	48,000	60,000	80,000	100,000	
Air Flow CFM Range	635-1100	795-1390	1060-1850	1240-2050	
Static Pressure (max)	0.7	0.7	0.8	0.8	
Air Temp. Rise (°F)	40-70	40-70	40-70	45-75	
Motor Speeds	3	3	3	3	
Motor Data	Horsepower	1/4	1/3	1/2	1/2
	RPM	Max 1,100	Max 1,100	Max 1,100	Max 1,100
	Type	P.S.C.	P.S.C.	P.S.C.	P.S.C.
	Amps	5.4	7.1	9.5	9.5
Unit Total Amps	6.4	8.1	11.5	11.5	

# DIMENSIONAL DATA - MODEL HD/HDB

## Propeller Units - Model HD

Figure 16.1 - Dimensional Drawings - Model HD

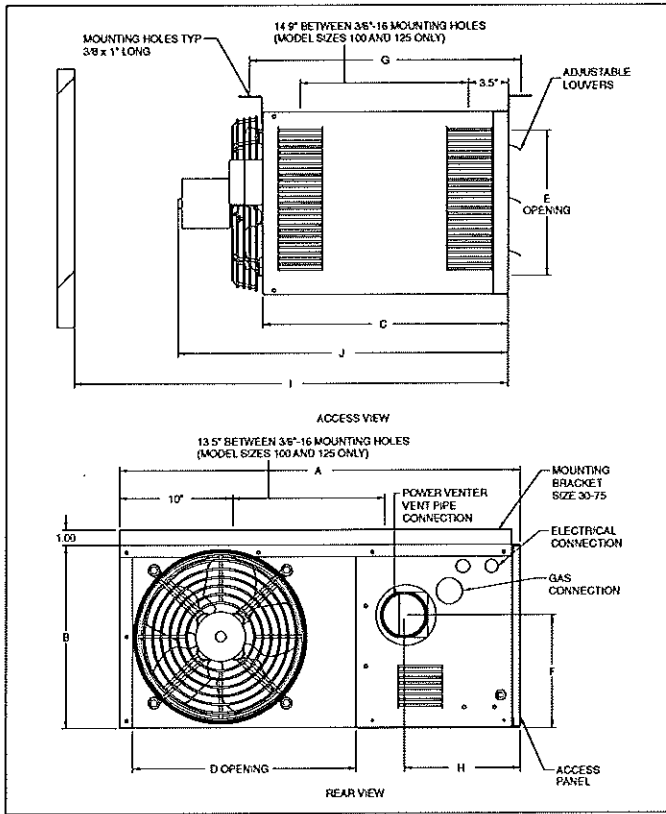


Table 16.1 - Dimensions (inches) - HD

Models	HD30	HD45	HD60	HD75	HD100/125
A	26.8	26.8	26.8	26.8	35.5
B	12.2	12.2	18.0	18.0	20.5
C	16.5	16.5	16.5	16.5	22.0
D	14.9	14.9	14.9	14.9	22.5
E	10.1	10.1	15.9	15.9	18.4
F	7.5	7.5	10.7	10.7	14.0
G	18.5	18.5	18.5	18.5	-
H	7.6	7.6	7.8	7.8	8.4
Gas Connection	1/2	1/2	1/2	1/2	1/2
I	34.5	34.5	34.5	34.5	43.0
J	22	22	25	25	31.0
Fan Diameter	10	10	14	14	18.0
Approx. Shipping Weight (lbs.)	55	60	80	85	125
Vent Connector Size (in)	3	3	3	3	4

Table 16.3 - Clearance to Combustibles, Model HD/HDB

Unit Side	Clearance To Combustible Materials	Recommended Service Clearance
Top and Bottom	1"	1"
Access Side	1"	18"
Non-Access Side	1"	1"
Rear	18"	18"
Vent Connector	4"	4"

## Blower Units - Model HDB

Figure 16.2 - Dimensional Drawings - Model HDB

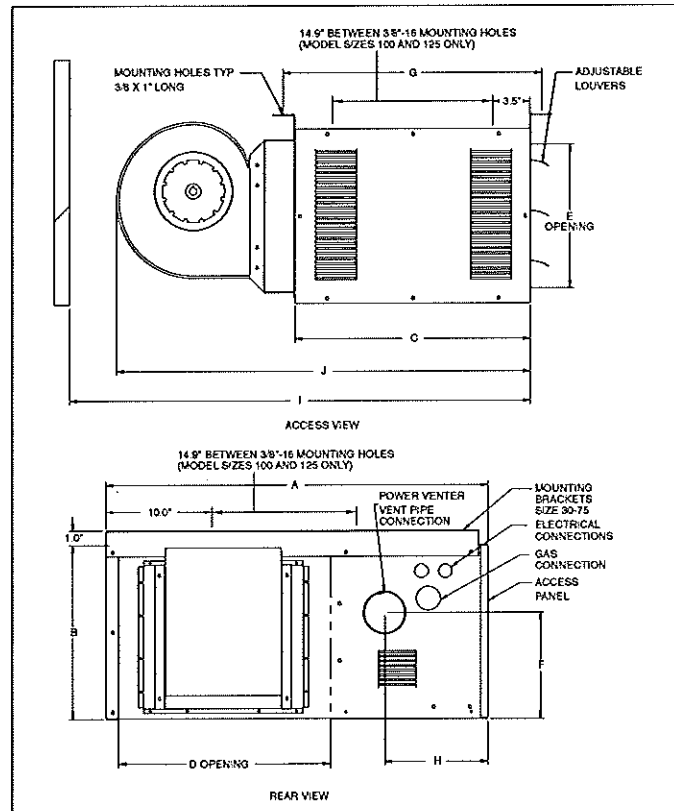
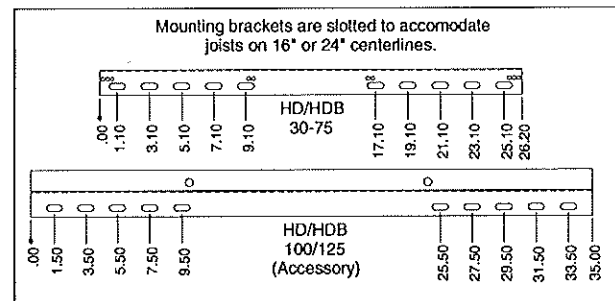


Table 16.2 - Dimensions (inches) - HDB

Models	HDB 60	HDB 75	HDB100/125
A	26.8	26.8	35.5
B	18.0	18.0	20.5
C	16.5	16.5	22.0
D	14.9	14.9	22.5
E	15.9	15.9	18.4
F	10.7	10.7	14.0
G	18.5	18.5	-
H	7.8	7.8	8.4
Gas Connection	1/2	1/2	1/2
I	34.5	34.5	44.5
J	25.0	25.0	41.5
Blower	9 - 7	9 - 7	10 - 10
Approx. Shipping Weight (lbs.)	92	97	151
Vent Connector Size (in)	3	3	4

## Mounting





# SERVICE / MAINTENANCE / TROUBLESHOOTING

**! WARNING**

When servicing or repairing this equipment, use only factory-approved service replacement parts. A complete replacement parts list may be obtained by contacting the factory. Refer to the rating plate on the appliance for complete appliance model number, serial number, and company address. Any substitution of parts or controls not approved by the factory will be at the owner's risk.

**! CAUTION**

1. Service or repair of this equipment must be performed by a qualified service agency.
2. Do not attempt to reuse any mechanical or electrical controllers which have been wet. Replace defective controller.

**! IMPORTANT**

To check most of the Possible Remedies in the troubleshooting guide listed in Table 19.1, refer to the applicable sections of the manual.

## General Maintenance

The unit and venting system must be checked once a year by a qualified service technician.

All installation and service of these units must be performed by a qualified installation and service agency.

Before any service, BE SURE TO TURN OFF GAS AT THE MANUAL SHUT-OFF VALVE AHEAD OF THE COMBINATION GAS CONTROL AND TURN OFF ALL ELECTRIC POWER TO THE HEATER.

1. Service air moving components annually.
  - a. Check fan for fit on motor shaft and for damage to blades.
2. Keep unit free from dust, dirt, grease, and foreign matter, paying particular attention to:
  - a. Combustion air inlets.
  - b. Burners and burner orifices. Turn off gas ahead of the combination gas control and shut off electric power to the heater. Remove the access panel, open the union on the gas line, and disconnect the igniter and sensor wires. Remove the screws that attach the burner tray to the header plate and remove the burner tray and manifold assembly from the heater. Carefully clean the burners with a wire brush or other suitable means. Replace any damaged or deteriorating burners or orifices. Install the burner assembly back on to the header making certain that all screws, pipes and electrical connections are tight.

**CAUTION:** Be careful when handling the igniter and flame sensor.

  1. Inspect the flame sensor and igniter for deterioration and/or cracks.
  2. Verify that the burners are touching each other at the carryover points. This will ensure flame carryover from burner to burner.
- c. Clean exterior of heat exchanger tubes.
- d. Fan blades.
3. Check wiring for possible loose connections.
4. Controls – The gas valves and piping should be checked annually for general cleanliness and tightness. The gas controls should be checked to insure that the unit is operating properly. See control instruction sheets furnished separately with the unit heater.
5. Power exhaust assembly/motor – The power exhaust motor bearings have been lubricated for long life and do not require additional lubrication. In dirty environments, it may be desirable to clean the motors and blower housing and blow out the cooling air passages of the motor with compressed air.
6. Perform periodic cleaning of inlet and vent terminal screens.

Table 17.1 - Troubleshooting

TROUBLE	POSSIBLE CAUSE	POSSIBLE REMEDY
Unit does nothing	<ol style="list-style-type: none"> <li>1. Power supply is off</li> <li>2. No 24V power to thermostat</li> <li>3. Thermostat malfunction</li> <li>4. LED flashes</li> <li>5. Defective control</li> </ol>	<ol style="list-style-type: none"> <li>1. Turn on main power</li> <li>2 a. Check control transformer                             <ol style="list-style-type: none"> <li>b. If failed transformer - check thermostat wire gauge and length</li> </ol> </li> <li>3 a. Verify wire connections to R&amp;W terminals only                             <ol style="list-style-type: none"> <li>b. Check / replace thermostat</li> </ol> </li> <li>4. Check LED flash code</li> <li>5. Replace control</li> </ol>
LED light off or flashing	<ol style="list-style-type: none"> <li>1. Multiple causes</li> </ol>	<ol style="list-style-type: none"> <li>1. Control board LED flash codes vary with control type. A decal is installed in the unit giving a brief description of the applicable codes for the heater. For more detail, see the control board data sheet included with this manual.</li> </ol>
Unit starts, but does not ignite	<ol style="list-style-type: none"> <li>1. Main gas is off</li> <li>2. Air in gas line</li> <li>3. Main or manifold gas pressure</li> <li>4. Check gas valve switch</li> </ol>	<ol style="list-style-type: none"> <li>1. Open manual gas valve</li> <li>2. Purge gas line</li> <li>3. Set gas pressures per manual instructions</li> <li>4. Set gas valve switch to "ON" position</li> </ol>
Unit goes through cycle, but the burners go out in less than 10 seconds	<ol style="list-style-type: none"> <li>1. Reversed main power polarity</li> <li>2. Unit not grounded</li> <li>3. Flame not sensed</li> </ol>	<ol style="list-style-type: none"> <li>1. Black wire - HOT, White wire - NEUTRAL, Green wire - Ground</li> <li>2. Ground unit and verify quality of ground connection</li> <li>3. Check flame sense probe and connection</li> </ol>
Air circulating fan inoperable	<ol style="list-style-type: none"> <li>1. Loose connections</li> <li>2. Defective control board</li> <li>3. Defective fan motor</li> </ol>	<ol style="list-style-type: none"> <li>1. Check all connections</li> <li>2. Check control board data sheet and function</li> <li>3. Check fan motor</li> </ol>

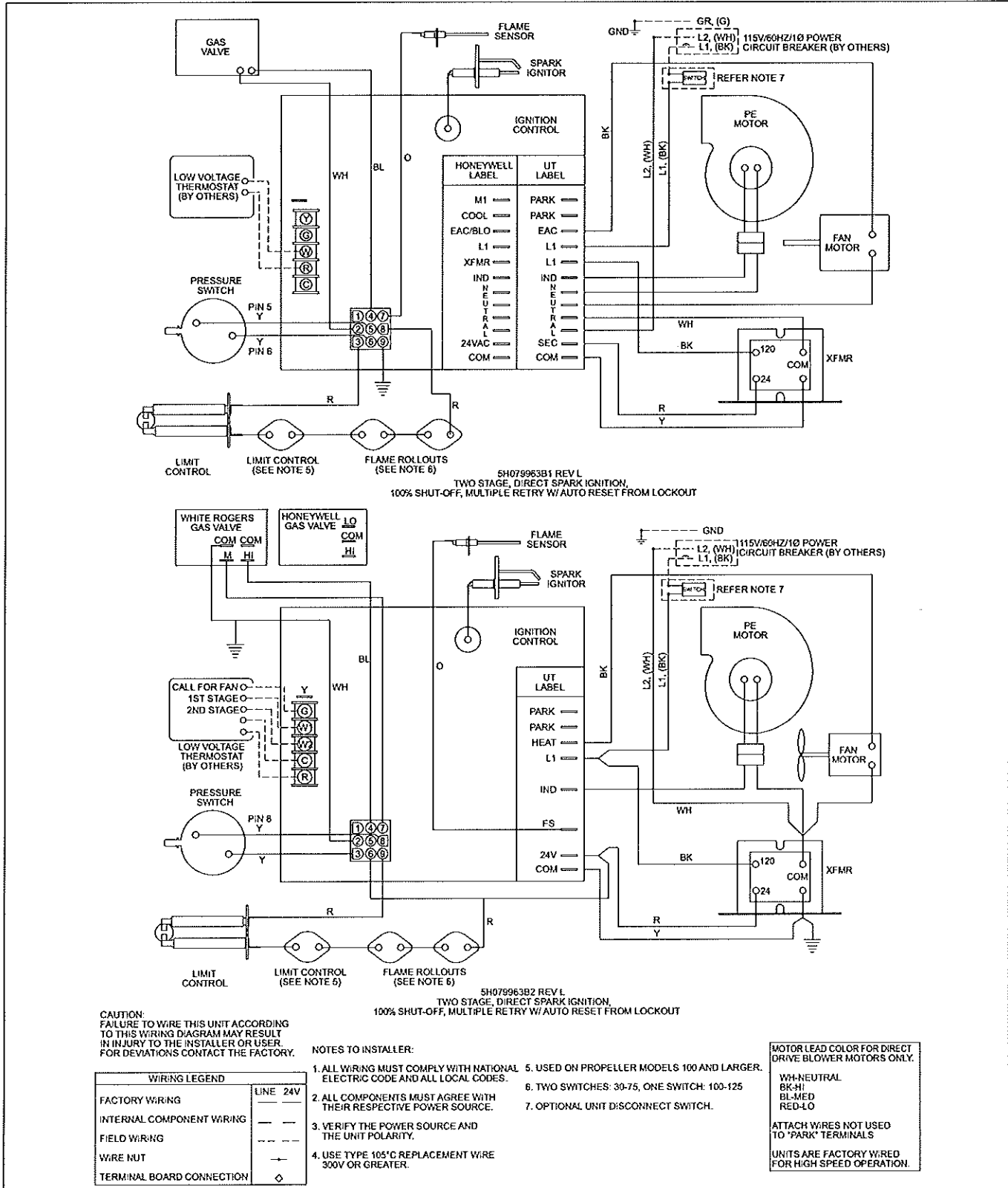
# UNIT WIRING

## Wiring Diagram Selection

Since internal or factory wiring may vary depending on the controls manufacturer, the wiring diagrams must be appropriately selected with the proper gas valve and ignition

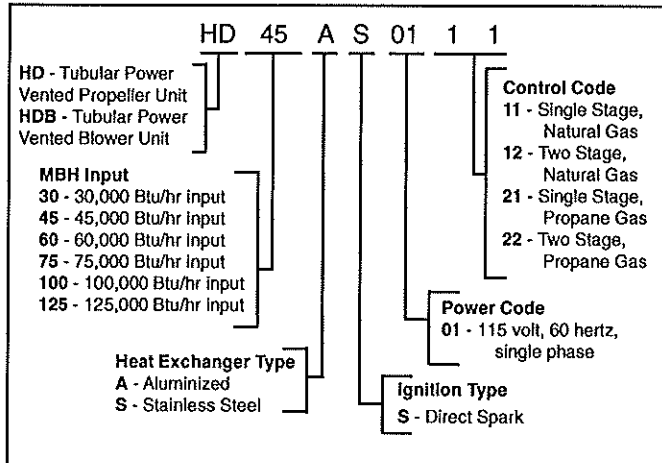
type. The following wiring diagram represents a unit equipped with a single or two stage gas valve and direct spark ignition.

Figure 18.1 - Unit Heater Wiring Diagram (Single and Two Stage, Direct Spark Ignition)

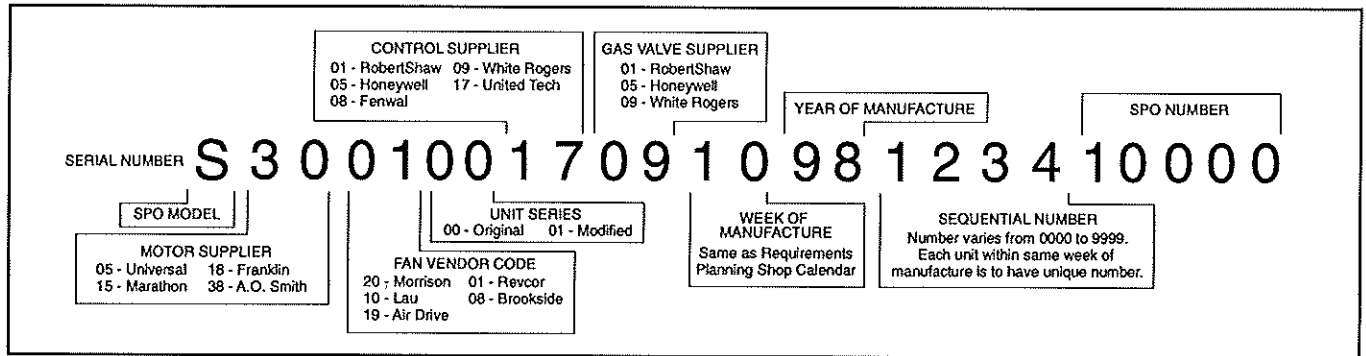


# SERIAL & MODEL NUMBER / REPLACEMENT PARTS

## Model Number Designations (Remove access cover to locate)



## Serial Number Designations (Remove access cover to locate)



## Replacement Parts

When requesting parts please contact your local representative. Please have full model and serial number available. If you require assistance in locating your representative, please call the number located on the back page.

**Figure 22.1 - Common Replacement Parts** (The list is subject to change. Please refer to unit mounted parts list for most up-to-date list.)

Model Size	Power Exhauster	Limit Control Switch	Flame Roll-out Switch	Trans-former	Pressure Switch	Igniter	Ignition Control (1 Stage)	Combination Gas Valve (1 Stage)		Ignition Control (2 Stage)	Combination Gas Valve (2 Stage)	
								Code 11	Code 21		Code 12	Code 22
HD 30	5H75038	5H75769B1	5H75002-7	5H75029	5H75030-3	5H79636	5H79749	5H79751B	5H79869B	NA	NA	NA
HD 45	5H75038	5H75769B1	5H75002-7	5H75029	5H75030-3	5H79636	5H79749	5H79751B	5H79869B	NA	NA	NA
HD 60	5H75038	5H75769B2	5H75002-7	5H75029	5H75030-3	5H79636	5H79749	5H79751B	5H79869B	NA	NA	NA
HDB 60	5H75038	5H75769B4	5H75002-7	5H75029	5H75030-3	5H79636	5H79749	5H79751B	5H79869B	NA	NA	NA
HD 75	5H75038	5H75769B2	5H75002-7	5H75029	5H75030-4	5H79636	5H79749	5H79751B	5H79869B	5H79804B	5H79748B	5H79871B
HDB 75	5H75038	5H75769B2	5H75002-7	5H75029	5H75030-4	5H79636	5H79749	5H79751B	5H79869B	5H79804B	5H79748B	5H79871B
HD 100	5H79795	5H75769B2	5H75002-4	5H75029	5H79441-9	5H79636	5H79749	5H79751B	5H79869B	5H79804B	5H79748B	5H79871B
HDB 100	5H79795	5H75769B3	5H75002-4	5H75029	5H79441-9	5H79636	5H79749	5H79751B	5H79869B	5H79804B	5H79748B	5H79871B
HD 125	5H79795	5H75769B1	5H75002-4	5H75029	5H79441-9	5H79636	5H79749	5H79751B	5H79869B	5H79804B	5H79748B	5H79871B
HDB 125	5H79795	5H75769B2	5H75002-4	5H75029	5H79441-9	5H79636	5H79749	5H79751B	5H79869B	5H79804B	5H79748B	5H79871B

# COMMERCIAL WARRANTY

Seller warrants its products to be free from defects in material and workmanship, EXCLUSIVE, HOWEVER, of failures attributable to the use of materials substituted under emergency conditions for materials normally employed. This warranty covers replacement of any parts furnished from the factory of Seller, but does not cover labor of any kind and materials not furnished by Seller, or any charges for any such labor or materials, whether such labor, materials or charges thereon are due to replacement of parts, adjustments, repairs, or any other work done. This warranty does not apply to any equipment which shall have been repaired or altered outside the factory of Seller in any way so as, in the judgment of Seller, to affect its stability, nor which has been subjected to misuse, negligence, or operating conditions in excess of those for which such equipment was designed. This warranty does not cover the effects of physical or chemical properties of water or steam or other liquids or gases used in the equipment.

BUYER AGREES THAT SELLER'S WARRANTY OF ITS PRODUCTS TO BE FREE FROM DEFECT IN MATERIAL AND WORKMANSHIP, AS LIMITED HEREIN, SHALL BE IN LIEU OF AND EXCLUSIVE OF ALL OTHER WARRANTIES, EITHER EXPRESS OR IMPLIED, WHETHER ARISING FROM LAW, COURSE OF DEALING, USAGE OF TRADE, OR OTHERWISE, THERE ARE NO OTHER WARRANTIES, INCLUDING WARRANTY OF MERCHANTABILITY OR FITNESS FOR PURPOSE, WHICH EXTEND BEYOND THE PRODUCT DESCRIPTION CONFIRMED BY BUYER AND SELLER AS OF THE DATE OF FINAL AGREEMENT.

This warranty is void if the input to the product exceeds the rated input as indicated on the product serial plate by more than 5% on gas-fired and oil-fired units, or if the product in the judgment of SELLER has been installed in a corrosive atmosphere, or subjected to corrosive fluids or gases, been subjected to misuse, negligence, accident, excessive thermal shock, excessive humidity, physical damage, impact, abrasion, unauthorized alterations, or operation contrary to SELLER'S printed instructions, or if the serial number has been altered, defaced or removed.

BUYER AGREES THAT IN NO EVENT WILL SELLER BE LIABLE FOR COSTS OF PROCESSING, LOST PROFITS, INJURY TO GOODWILL, OR ANY OTHER CONSEQUENTIAL OR INCIDENTAL DAMAGES OF ANY KIND RESULTING FROM THE ORDER OR USE OF ITS PRODUCT, WHETHER ARISING FROM BREACH OF WARRANTY, NONCONFORMITY TO ORDERED SPECIFICATIONS, DELAY IN DELIVERY, OR ANY LOSS SUSTAINED BY THE BUYER.

BUYER'S REMEDY FOR BREACH OF WARRANTY, EXCLUSIVE OF ALL OTHER REMEDIES PROVIDED BY LAW, IS LIMITED TO REPAIR OR REPLACEMENT AT THE FACTORY OF SELLER, ANY COMPONENT WHICH SHALL, WITHIN THE APPLICABLE WARRANTY PERIOD DEFINED HEREIN AND UPON PRIOR WRITTEN APPROVAL, BE RETURNED TO SELLER WITH TRANSPORTATION CHARGES PREPAID AND WHICH THE EXAMINATION OF SELLER SHALL DISCLOSE TO HAVE BEEN DEFECTIVE; EXCEPT THAT WHEN THE PRODUCT IS TO BE USED BY BUYER AS A COMPONENT PART OF EQUIPMENT MANUFACTURED BY BUYER, BUYER'S REMEDY FOR BREACH, AS LIMITED HEREIN, SHALL BE LIMITED TO ONE YEAR FROM DATE OF SHIPMENT FROM SELLER. FOR GAS-FIRED PRODUCTS INSTALLED IN HIGH HUMIDITY APPLICATIONS AND UTILIZING STAINLESS STEEL HEAT EXCHANGERS, BUYER'S REMEDY FOR BREACH, AS LIMITED HEREIN, SHALL BE LIMITED TO TEN YEARS FROM DATE OF SHIPMENT FROM SELLER.

These warranties are issued only to the original owner-user and cannot be transferred or assigned. No provision is made in these warranties for any labor allowance or field labor participation. Seller will not honor any expenses incurred in its behalf with regard to repairs to any of Seller's products. No credit shall be issued for any defective part returned without proper written authorization (including, but not limited to, model number, serial number, date of failure, etc.) and freight prepaid.

### OPTIONAL SUPPLEMENTAL WARRANTY

Provided a supplemental warranty has been purchased, Seller extends the warranty herein for an additional four (4) years on certain compressors. Provided a supplemental warranty has been purchased, Seller extends the warranty herein for an additional four (4) years or nine (9) years on certain heat exchangers.

### EXCLUSION OF CONSUMABLES & CONDITIONS BEYOND SELLER'S CONTROL

This warranty shall not be applicable to any of the following items: refrigerant gas, belts, filters, fuses and other items consumed or worn out by normal wear and tear or conditions beyond Seller's control, including (without limitation as to generality) polluted or contaminated or foreign matter contained in the air or water utilized for heat exchanger (condenser) cooling or if the failure of the part is caused by improper air or water supply, or improper or incorrect sizing of power supply.

<b>Component</b> Applicable Models	<b>"APPLICABLE WARRANTY PERIOD"</b>
<b>Heat Exchangers</b> Gas-Fired Units except PSH/BSH	TEN YEARS FROM DATE OF FIRST BENEFICIAL USE BY BUYER OR ANY OTHER USER, WITHIN TEN YEARS FROM DATE OF RESALE BY BUYER OR ANY OTHER USER, WITHIN TEN YEARS FROM DATE OF RESALE BY BUYER IN ANY UNCHANGED CONDITION, OR WITHIN ONE HUNDRED TWENTY-SIX MONTHS FROM DATE OF SHIPMENT FROM SELLER, WHICHEVER OCCURS FIRST
<b>Heat Exchangers</b> Low Intensity Infrared Units  <b>Compressors</b> Condensing Units for Cassettes	FIVE YEARS FROM DATE OF FIRST BENEFICIAL USE BY BUYER OR ANY OTHER USER, WITHIN FIVE YEARS FROM DATE OF RESALE BY BUYER OR ANY OTHER USER, WITHIN FIVE YEARS FROM DATE OF RESALE BY BUYER IN ANY UNCHANGED CONDITION, OR WITHIN SIXTY-SIX MONTHS FROM DATE OF SHIPMENT FROM SELLER, WHICHEVER OCCURS FIRST
<b>Burners</b> Low Intensity Infrared Units  <b>Other</b> Components excluding Heat Exchangers, Coils, Condensers, Burners, Sheet Metal	TWO YEARS FROM DATE OF FIRST BENEFICIAL USE BY BUYER OR ANY OTHER USER, WITHIN TWO YEARS FROM DATE OF RESALE BY BUYER IN ANY UNCHANGED CONDITION, OR WITHIN THIRTY MONTHS FROM DATE OF SHIPMENT FROM SELLER, WHICHEVER OCCURS FIRST
<b>Heat Exchangers/Coils</b> Indoor and Outdoor Duct Furnaces and System Units, PSH/BSH, Steam/Hot Water Units, Oil-Fired Units, Electric Units, Cassettes, Vertical Unit Ventilators  <b>Compressors</b> Vertical Unit Ventilators  <b>Burners</b> High Intensity Infrared Units  <b>Sheet Metal Parts</b> All Products	ONE YEAR FROM DATE OF FIRST BENEFICIAL USE BY BUYER OR ANY OTHER USER, WITHIN ONE YEAR FROM DATE OF RESALE BY BUYER IN ANY UNCHANGED CONDITION, OR WITHIN EIGHTEEN MONTHS FROM DATE OF SHIPMENT FROM SELLER, WHICHEVER OCCURS FIRST

As Modine Manufacturing Company has a continuous product improvement program, it reserves the right to change design and specifications without notice.



Commercial Products Group  
 Modine Manufacturing Company  
 1500 DeKoven Avenue  
 Racine, WI 53403  
 Phone: 1.800.828.4328 (HEAT)  
 www.modinehvac.com