

# TRANE XL-80

## TWO STAGE - UPFLOW

<b>MODEL NUMBER:</b>	UD040R924A UD080R948A UD100R960A UD120R960A	UD060R936A UD100R936A UD100R960B UD140R960A	UD080R936A UD100R948A UD120R954A
<b>BTU SIZES:</b>	Size of furnace is determined by 4th and 5th digit of model #. (Example: UD040R924A= 40,000 BTU's)		

### ACCESSIBILITY CLEARANCE

A minimum of 24 inches front clearance to the furnace must be provided. Any access door or panel must permit removal of the largest component.

### CLEARANCE FROM COMBUSTIBLE MATERIAL

**Minimum clearances**

- Front            6"
- Sides            0"
- Rear & bottom 0"
- Plenum          1"
- Vent "B1"       1"
- Vent, Type "C" 6"

**WARNING: Do not install the furnace directly on carpeting, tile or other combustible material other than wood flooring.**

### COLD AIR RETURN AIR DUCTS

On any job, flexible duct connectors of a non-flammable material are recommended to connect both return air and discharge air ducts to the furnace to prevent transmission of vibration.

When there is no complete return duct system, the return connection must be run full size from the furnace to a location outside the utility room, basement, attic, or crawl space.

**Do Not connect return air through the back of the furnace cabinet.**

### GARAGE

If this furnace is installed in a **residential garage**, it must be installed so that the bottom of the appliance is not less than 18 inches above the floor and the furnace must be located and protected to avoid physical damage from vehicles.

GENERAL

HIGH ALTITUDE INSTALLATIONS

Deration	If the installation is 2,000 ft. or above, ratings should be reduced at the rate of 4% for each 1,000 ft. above sea level.																
Orifice	Orifice change only																
Regulator Pressure	FINAL MANIFOLD PRESSURE SETTINGS																
	<table border="0" style="width: 100%;"> <tr> <td style="width: 15%;">Fuel</td> <td style="width: 20%; text-align: center;">1st Stage</td> <td style="width: 20%; text-align: center;">2nd Stage</td> <td style="width: 45%;"></td> </tr> <tr> <td></td> <td style="text-align: center;"><u>Minimum</u></td> <td style="text-align: center;"><u>Maximum</u></td> <td style="text-align: center;"><u>Minimum</u>      <u>Maximum</u></td> </tr> <tr> <td>Natural Gas</td> <td style="text-align: center;">1.4" W.C.</td> <td style="text-align: center;">1.7" W.C.</td> <td style="text-align: center;">3.0" W.C.      3.7" W.C.</td> </tr> <tr> <td>LP Gas</td> <td style="text-align: center;">4.0" W.C.</td> <td style="text-align: center;">4.5" W.C.</td> <td style="text-align: center;">10.0" W.C.      10.5" W.C.</td> </tr> </table>	Fuel	1st Stage	2nd Stage			<u>Minimum</u>	<u>Maximum</u>	<u>Minimum</u> <u>Maximum</u>	Natural Gas	1.4" W.C.	1.7" W.C.	3.0" W.C.      3.7" W.C.	LP Gas	4.0" W.C.	4.5" W.C.	10.0" W.C.      10.5" W.C.
Fuel	1st Stage	2nd Stage															
	<u>Minimum</u>	<u>Maximum</u>	<u>Minimum</u> <u>Maximum</u>														
Natural Gas	1.4" W.C.	1.7" W.C.	3.0" W.C.      3.7" W.C.														
LP Gas	4.0" W.C.	4.5" W.C.	10.0" W.C.      10.5" W.C.														
Pressure Switch	Use high altitude kit for installations above 4,000 ft. (a pressure switch change is required).																

MOBILE HOME

Not approved.

VENTING MATERIAL AND REQUIREMENTS

Vent Pipe	See High Temperature Plastic Sidewall Vent Materials table. (included)
Vent Fittings	All *UD-R and *DD-R furnaces must use Bayvent300(3") or Bayvent400(4") as the vent termination for proper operation of the furnace.

High temperature plastic vent on all UPFLOW model furnaces MUST have a rise of 18 inches of 4 inch pipe before being reduced or the first elbow to start a horizontal run.

VENT CLEARANCE FROM COMBUSTIBLE MATERIAL

- 3" High temperature plastic pipe and fittings - 5"
- 4" High temperature plastic pipe and fittings - 9"

## VENTING PROCEDURE

The \*UD-R series furnaces have been classified as Fan Assisted Category I furnaces.

See Allowable Horizontal Vent Lengths table. (included)

### HIGH TEMPERATURE PLASTIC

Condensate drain: NOTE: The horizontal vent pipe run must maintain at least 1/4 inch rise per foot from the furnace to the vent termination. The condensate drain should be located in the horizontal run of pipe as close to the furnace as possible while allowing a straight drop of the drain tubing. Drain tubing for 3 inch pipe is 3/8 inch I.D. tubing and for the 4 inch pipe the tubing is 5/8 inch I.D. tubing. The drain tubing must be trapped by forming a loop approximately 3 feet 6 inches below the drain tee.

## MISCELLANEOUS INFORMATION/NOTES

The following type of installations will require use of OUTDOOR AIR for combustion, due to chemical exposures: Commercial buildings, buildings with indoor pools, furnaces installed in commercial laundry rooms, furnaces installed in hobby or craft rooms, and furnaces installed near chemical storage areas.

Exposures to the flowing substances in the combustion air supply will also required OUTDOOR AIR for combustion: Permanent wave solutions, chlorinated waxes and cleaners, chlorine based swimming pool chemicals, water softening chemicals, De-icing salts or chemicals, Carbon Tetrachloride, Halogen type refrigerants, cleaning solvents (such as perchlorethylene), printing inks, paint removers, varnish, etc., Hydrochloric acid, cements and glues, anti-static fabric softeners for clothes dyers, and masonry acid washing materials.

## SEQUENCE OF OPERATION

### Thermostat call for heat (2-stage thermostat)

#### Call for 1st Stage only:

R and W1 thermostat contacts close signaling the control module to run its self-check routine. After the control module has verified that the 1st stage pressure switch contacts are open and the limit switch(es) contacts are closed, the draft blower will be energized.

As the induced draft blower comes up to speed, the pressure switch contacts will close and the ignitor warm up period will begin. The ignitor will heat for approximately 17 seconds, then the gas valve is energized in 1st stage to permit gas flow to the burners. The flame sensor confirms that the ignition has been achieved within the 6 second ignition trial.

As the flame sensor confirms that ignition has been achieved, the delay to fan ON period begins timing and after approximately 45 seconds the I.D. blower motor will be energized at low speed and will continue to run during the heating cycle.

#### Call for 2nd stage after 1st stage:

R and W2 thermostat contacts close signaling a call for 2nd stage heat. After a 30 second delay, the induced draft blower will be energized on high speed and the 2nd stage pressure switch contacts will close allowing the gas valve to be energized in 2nd stage and the I.D. blower motor in high speed.

### 2nd stage satisfied, 1st stage still called:

R and W2 thermostat contacts open signaling that 2nd stage heating requirements are satisfied. The induced draft blower is reduced to low speed allowing the 2nd stage pressure switch contacts to open and the gas valve is reduced to 1st stage. After approximately 30 seconds the I.D. blower motor is reduced to low speed.

### 1st stage satisfied

R and W1 thermostat contacts open signaling that 1st stage heating requirements are satisfied. The gas valve will close and the induced draft blower will be de-energized. The I.D. blower motor will continue to run for the fan off period (Field selectable at 90, 120, 150, or 210 seconds), then will be de-energized by the control module.

### Thermostat call for heat (1-stage thermostat)

R and W1/W2 (jumpered) thermostat contacts close signaling a call for heat. 1st stage sequence of operation remains the same as above. 2nd stage heat has a 10 minute delay from the time of 1st stage ignition.

### Thermostat satisfied

R and W1/W2 (jumpered) contacts open signaling the control module to close the gas valve and de-energize the induced draft blower. The I.D. blower motor will continue to operate at high heat speed for approximately 30 seconds after the flames are extinguished and then is switched to low heat speed for the remaining FAN-OFF period.

# VENTING

## HIGH TEMPERATURE PLASTIC SIDEWALL VENT MATERIALS

Item Description	Hart/Cooley 3" Pipe	Plexco 3" Pipe	Plexco 4" Pipe
Pipe - 5 feet	EUP5	901220	903851
Pipe - 10 feet	3UP10	902474	-
90° sweep elbow	3UES90	902299	905772
45° elbow	3UE45	903958	905773
Tee	3UT	905268	903854
Drain tee lateral	3UT	901761	903929
Cond. drain (flex)	3UDP	906646	903855
Coupling (transparent)*	3UC	901218	903853
Coupling (black)*	-	905630	905807
Wall thimble	3UWT	-	-
4" to 3" reducer	4UR3	905744	905744
Sealant	URTV	DOW736RTV	DOW736RTV

Use 902606, 905295, 905662, or 906972  
Transparent fittings are for indoor use only.  
Black fittings may be used inside or outside.

Use 902615 or 907094

## VENTING PROCEDURE:

ALLOWABLE HORIZONTAL VENT LENGTHS			
MODEL INPUT	ALLOWABLE VENT SIZE	MAXIMUM EQUIVALENT* LENGTH	TERMINATION TEE REQUIRED
040, 060, 080	3"	55 FT + TERM. TEE	BAYVENT300
100, 120	4"	55 FT + TERM. TEE	BAYVENT400
140	4"	45 FT + TERM. TEE	BAYVENT400

\* One 90° ELL = 10 equiv. ft.; One 45° Fitting = 5 equiv. ft. Each fitting's equivalent length is added to the pipe length to determine the overall equivalent length.

## Two Stage Variable Speed Sequence of Operation

White-Rodgers Integrated Furnace Controls 50A51-505 – \*UD/\*DD-R-V Models  
50A51-506 – \*UY/\*DY-R-V Models

When the service disconnect ① is in the "ON" position, power is applied through the blower door interlock switch ② to the controls line voltage input terminals ⑤⑫ and out of the control to the primary side of the control transformer ④, and from the "CIRC" ⑥ terminal to the ICM Fan Motor ②. The secondary side of the control transformer supplies 24 volts to the control through terminal "TH" and "TR" ⑳, ㉑. Control terminal "R" ㉒ supplies 24 volts to the "R" terminal of the room thermostat.

Once power is applied, the control flashes the LED light "ON" for one second and performs a self check routine. Following the normal system check, the control flashes the LED one time per second (slow flash) continuously while in stand-by.

On a call for heat, 24 volts is applied from the room thermostats "W1" terminal to the "W1" terminal ㉓ on the control. The control checks and confirms normally closed contacts at the temperature cut out "TCO" ⑰, auxiliary limit (downflow only), the flame roll-out fuse link (two fuse links are used on downflow models) ⑰ and normally open contacts at the safety pressure switch #1 ⑮. With all safety and control switches in their proper position, the control will energize the induced draft motor on high speed ⑧, ⑩ and flashes the LED two times per second continuously (fast flash) during a call for heat.

When safety pressure switch "#1" ⑮ closes, the control switches the induced draft motor to low speed ⑨, ⑩ and begins the ignition sequence. The hot surface ignitor ⑦, ⑪ is energized for 17 seconds allowing the thermal element to heat up. The control then switches 24 volts to its "MVL" ㉔ and "MV COM" ㉕ terminals to terminals #1 ㉖ and #2 ㉗ on the gas valve. The redundant and main solenoids are energized allowing gas flow and main burner ignition. When flame current is sensed by the control through its "FP" ⑱ terminal, the 45 second indoor blower motor time delay "ON" begins. Flame failure response time is set for 2 seconds. After flame has been established for 10 seconds, the flame failure response time is reset for .8 seconds. If flamed current is not sensed by the control ⑱ within the 6 second trial for ignition period, the main valve low and redundant gas valve solenoids ㉔, ㉕ are de-energized. The control will begin a 30 second interpurge cycle and add 10 seconds to the hot surface ignitor warm-up timing. The control energizes the gas valve for the second attempt to establish main burner ignition. If again flame current is not sensed by the control within the 6 second trial for ignition period, the control will repeat the previous cycle before locking out. At the end of the indoor blower motor delay "ON" timing, the microprocessor will close the normally open K3 relay contacts ㉘ completing a 24 volt signal to pin #15 of the ICM motor, energizing the indoor blower motor at low heat fan speed, supplying warm air to the space.

If the temperature in the space continues to fall, the thermostat second stage contacts "W2" close. 24 volts is switched from thermostat terminal "W2" to the "W2" terminal ㉙ on the control. A 30 second, 2nd stage recognition time delay begins. At the end of the 30 second delay, the induced draft motor is switched to high speed ⑧, ⑩ causing pressure switch #2 ⑲ to close. When pressure switch #2 closes, 24 volts is switched from control terminal "MVH" ㉚ to the gas valve terminal #3 ⑲ energizing the second stage solenoid allowing increased gas flow to the burners. At the same time, the microprocessor closes the normally open K1 relay contacts ㉘ completing a 24 volt circuit to pin #13 ㉛ of the ICM-II motor energizing the high heat fan speed.

When second stage thermostat contacts "W2" satisfy, the induced draft motor is switched back to low speed ⑨, ⑩ causing pressure switch #2 ⑲ to open breaking the circuit to the second stage gas valve solenoid ⑲. Gas flow is reduced to the burners. The indoor ICM blower motor ④ will switch back to low heat fan speed after a 30 second delay.

When first stage thermostat contacts "W1" satisfy, the main valve low and the redundant gas valve solenoids ㉔, ㉕ are de-energized extinguishing main burner flame. Once the control senses the loss of flame current (.8 sec.) ⑱, the induced draft motor ⑨, ⑩ is de-energized after a five second post-purge cycle. The indoor blower motor "OFF" timing begins. At the end of the indoor blower motor "OFF" timing, the indoor blower motor is de-energized and the cycle is complete.

\* Models maybe an A or T

# Wiring Schematic

## Two Stage Variable Speed (White-Rodgers 50A51-505/50A51-506 Integrated Furnace Control)

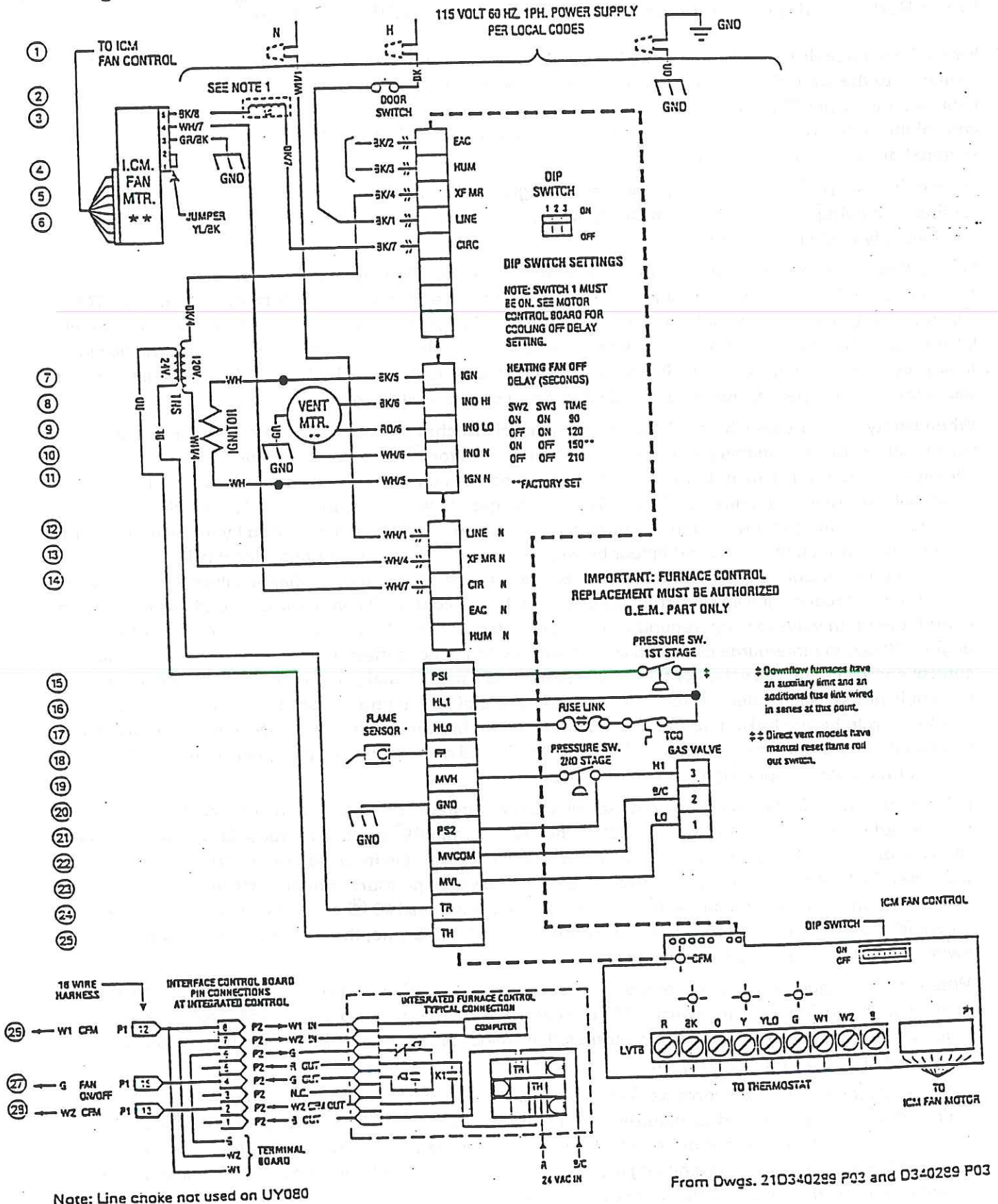

From Dwg. 21D340299 P03 and D340299 P03

## Two Stage 50A51-405 Sequence of Operation

### White-Rodgers Integrated Furnace Control 50A51-405 – \*UD/\*DD-R Models

When the service disconnect ① is in the "ON" position, power is applied through the blower door interlock switch ② to the controls line voltage input terminals ⑤ and out of the control to the primary side of the control transformer "XFMR" ⑥②. The secondary side of the control transformer supplies 24 volts to the control through terminal "TH" and "TR" ②②. Control terminal "R" ②③ supplies 24 volts to the "R" terminal of the room thermostat.

Once power is applied, the control flashes the LED light "ON" for one second and performs a self check routine. Following the normal system check, the control flashes the LED one time per second (slow flash) continuously while in stand-by.

On a call for heat, 24 volts is applied from the room thermostats "W1" terminal to the "W1" terminal ②④ on the control. The control checks and confirms normally closed contacts at the temperature cut out "TCO" ⑬, auxiliary limit (downflow only), the flame roll-out fuse link (two fuse links are used on downflow models) ⑭ and normally open contacts at the safety pressure switch #1 ⑭. With all safety and control switches in their proper position, the control will energize the induced draft motor on high speed ⑧, ⑩ and flashes the LED two times per second continuously (fast flash) during a call for heat.

When safety pressure switch "#1" ⑭ closes, the control switches the induced draft motor to low speed ⑨, ⑩ and begins the ignition sequence. The hot surface ignitor ⑦, ⑪ is energized for 17 seconds allowing the thermal element to heat up. The control then switches 24 volts to its "MVL" and "MV COM" ②① terminals to terminals #1 ②② and #2 ②③ on the gas valve. The redundant and main solenoids are energized allowing gas flow and main burner ignition. When flame current is sensed by the control through its "FP" ⑰ terminal, the 45 second indoor blower motor time delay "ON" begins. Flame failure response time is set for 2 seconds. After flame has been established for 10 seconds, the flame failure response time is reset for .8 seconds. If flamed current is not sensed by the control ⑰ within the 6 second trial for ignition period, the main valve low and redundant gas valve solenoids ②④, ②⑤ are de-energized. The control will begin a 30 second interpurge cycle and add 10 seconds to the hot surface ignitor warm-up timing. The control energizes the gas valve for the second attempt to establish main burner ignition. If again flame current is not sensed by the control within the 6 second trial for ignition period, the control will repeat the previous cycle before locking out. At the end of the indoor blower motor delay "ON" timing, line voltage is applied at control terminal "HEAT LO" ④ and "CIR N." ③ energizing the indoor blower motor at low heat fan speed, supplying warm air to the space.

If the temperature in the space continues to fall, the thermostat second stage contacts "W2" close. 24 volts is switched from thermostat terminal "W2" to the "W2" terminal ②⑥ on the control. A 30 second, 2nd stage recognition time delay begins. At the end of the 30 second delay, the induced draft motor is switched to high speed ⑧, ⑩ causing pressure switch #2 ⑱ to close. When pressure switch #2 closes, 24 volts is switched from control terminal "MVH" ⑲ to the gas valve terminal #3 ⑲ energizing the second stage solenoid allowing increased gas flow to the burners. At the same time, the indoor blower motor is switched to high heat fan speed ⑤, ⑮.

When second stage thermostat contacts "W2" satisfy, the induced draft motor is switched back to low speed ⑨, ⑩ causing pressure switch #2 ⑱ to open breaking the circuit to the second stage gas valve solenoid ⑲. Gas flow is reduced to the burners. The indoor blower motor will switch back to low heat fan speed after a 30 second delay ④.

When first stage thermostat contacts "W1" satisfy, the main valve low and the redundant gas valve solenoids ②④, ②⑤ are de-energized extinguishing main burner flame. Once the control senses the loss of flame current (.8 sec.) ⑰, the induced draft motor ⑨, ⑩ is de-energized after a five second post-purge cycle. The indoor blower motor "OFF" timing begins. At the end of the indoor blower motor "OFF" timing, the indoor blower motor is de-energized and the cycle is complete.



# Wiring Schematic

## Two Stage Heat (White-Rodgers 50A51-405 Integrated Furnace Control)

115 VOLT 60 HZ. 1PH. POWER SUPPLY  
PER LOCAL CODES

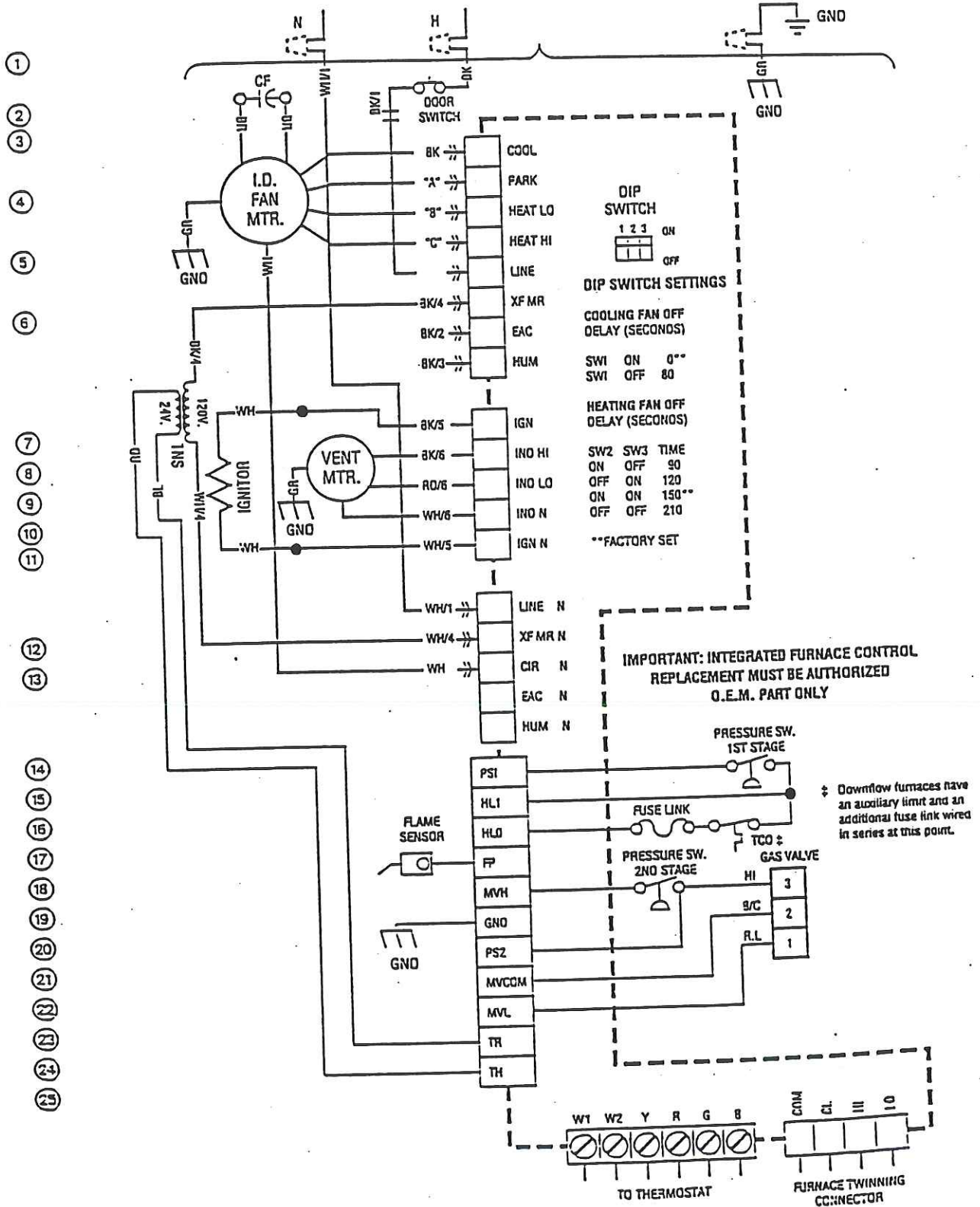

- 1
- 2
- 3
- 4
- 5
- 6
- 7
- 8
- 9
- 10
- 11
- 12
- 13
- 14
- 15
- 16
- 17
- 18
- 19
- 20
- 21
- 22
- 23
- 24
- 25

From Dwg. 2103:0043 P09

